

TMC7300 Datasheet

Low Voltage Driver for One or Two DC Motors up to 2A (2.4A) peak – UART based Control for Torque and Velocity. 4 Half Bridge Peripheral Driver Option.



APPLICATIONS

- IOT & Handheld devices
- Battery operated motors
- 4-Channel Relay- and LED driving
- Printers, POS
- Toys
- Office and home automation
- CCTV, Security
- HVAC
- Mobile medical devices

FEATURES AND BENEFITS

- Voltage Range** 2V (1.8V) ... 11V DC
- Battery Operation** min. 2 AA / NiMh cells, or 1-2 Li-Ion cells
- 1 / 2 DC motors** up to 2A / 2.4A with velocity & torque control
- Direct Bridge** control for solenoids, relays, lamps, motors...
- Single Wire UART** for two-motor torque and velocity control
- Standby** <50nA typ. current draw
- Low RDSon** LS 170mΩ & HS 170mΩ (typ.)
- Parallel Option** for single DC motor
- Motor Load Feedback** available
- Full Protection & Diagnostics**
- Tiny of QFN 3*3** with 20 pins

DESCRIPTION

Working from a single or dual Li-Ion cell or dual or more AA batteries the TMC7300 is optimally suited for battery operated equipment. Its two full-bridges allow either control of two DC motors, PWM-control of LEDs, or protected standalone peripheral driving, using a polarity signal per half-bridge. Operate up to two DC motors via simple UART control for direction, velocity and torque. Integrated power-MOSFETs with internal charge-pump for best-in-class RDSon even at low supply voltage, handle motor current up to 1.2A per motor continuously, or the double current in parallel connection. Together with a tiny standby current, this guarantees a long battery life. Protection and diagnostic features support robust and reliable operation. This advanced driver ensures efficient and reliable operation for cost-effective and highly competitive solutions.

BLOCK DIAGRAM

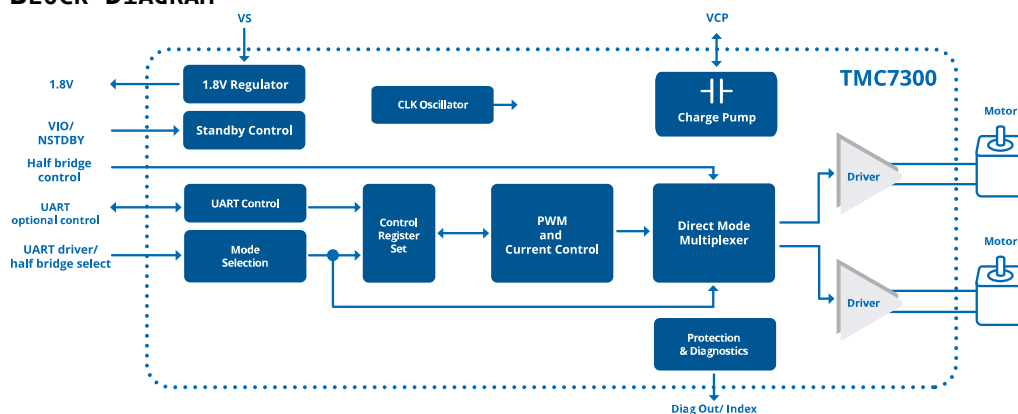

APPLICATION EXAMPLES: SIMPLE SOLUTIONS – HIGHLY EFFECTIVE

The TMC7300 scores with a high power density using integrated power MOSFETs and a complete integrated DC motor control logic, to control velocity and limit torque, or for torque controlled operation. It covers a wide spectrum of applications from battery systems to embedded applications with up to 2A (2.4A) current per motor. Extensive support enables rapid design cycles and fast time-to-market with highly competitive products.

UART INTERFACE FOR CONTROL OF 2 DC MOTORS

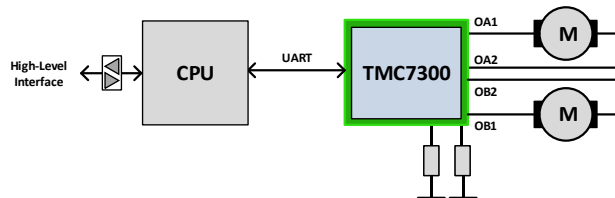

UART INTERFACE FOR CONTROL OF 1 DC MOTOR (UP TO 2.4A)

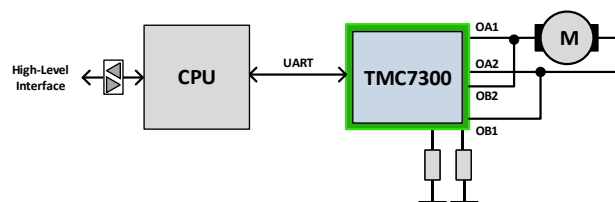

4 HALF BRIDGE PERIPHERAL DRIVERS

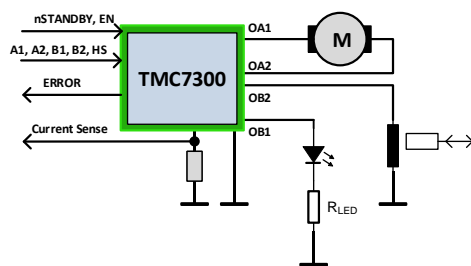

A CPU operates the driver via its UART interface. It configures motor direction and velocity as well as current limit, and accesses diagnostic information via the UART interface. The TMC7300 takes care for voltage and current regulation and overcurrent protection. With single motor operation, output current is increased and power dissipation is reduced.

The TMC7300 acts a peripheral driver for a low-voltage application. It drives resistive loads, like a LED, or inductive loads like motors or solenoids. It offers up to 2A peak output current while adding protection features.

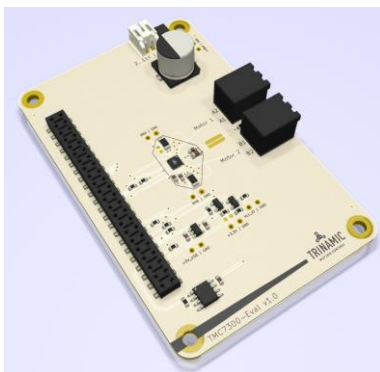

The TMC7300-EVAL is part of TRINAMICs universal evaluation board system which provides a convenient handling of the hardware as well as a user-friendly software tool for evaluation. The TMC7300 evaluation board system consists of three parts: STARTRAMPE (base board), Eselsbrücke (connector board with test points), and TMC7300-EVAL.

ORDER CODES

Order code	PN	Description	Size [mm ²]
TMC7300-LA	00-0191	Low voltage DC motor driver	3 x 3
TMC7300-LA-T	00-0191T	-T denotes tape on reel packing of devices	
TMC7300-BOB	40-0186	Break out Board with TMC7300	20 x 25
TMC7300-EVAL	40-0187	Evaluation board for TMC7300	85 x 55
ESELSBRÜCKE	40-0098	Connector board fitting to Landungsbrücke	61 x 38
LANDUNGSBRÜCKE	40-0167	Baseboard for TMC7300-EVAL and further evaluation boards	85 x 55

Table of Contents

1	PRINCIPLES OF OPERATION	4	7.1	MOTOR TORQUE LIMIT	29
1.1	CONTROL INTERFACES	5	8	DRIVER DIAGNOSTIC FLAGS	30
1.2	MOVING AND CONTROLLING THE MOTOR	6	8.1	TEMPERATURE MEASUREMENT	30
1.3	MECHANICAL LOAD SENSING	6	8.2	SHORT PROTECTION	30
1.4	PROTECTION AND DIAGNOSTICS	6	8.3	DIAGNOSTIC OUTPUT	31
2	PIN ASSIGNMENTS	7	9	QUICK CONFIGURATION GUIDE	32
2.1	PACKAGE OUTLINE TMC7300 (UART MODE)	7	10	EXTERNAL RESET	33
2.2	SIGNAL DESCRIPTIONS / UART MODE	7	11	CLOCK OSCILLATOR	33
2.3	PACKAGE OUTLINE / HALFBRIDGE MODE	8	12	ABSOLUTE MAXIMUM RATINGS	34
2.4	SIGNAL DESCRIPTIONS / HALFBRIDGE MODE	8	13	ELECTRICAL CHARACTERISTICS	34
3	SAMPLE CIRCUITS	10	13.1	OPERATIONAL RANGE	34
3.1	DC MOTOR OPERATION	10	13.2	DC AND TIMING CHARACTERISTICS	35
3.2	HALFBRIDGE DRIVER MODE	12	13.3	THERMAL CHARACTERISTICS	37
3.3	HIGHLY EFFICIENT DRIVER	13	14	LAYOUT CONSIDERATIONS	38
3.4	LOW POWER STANDBY	14	14.1	EXPOSED DIE PAD	38
3.5	VERY LOW I/O VOLTAGE OPERATION	14	14.2	WIRING GND	38
4	UART SINGLE WIRE INTERFACE	15	14.3	SUPPLY FILTERING	38
4.1	DATAGRAM STRUCTURE	15	14.4	LAYOUT EXAMPLE	39
4.2	CRC CALCULATION	17	15	PACKAGE MECHANICAL DATA	40
4.3	UART SIGNALS	17	15.1	DIMENSIONAL DRAWINGS QFN20	40
4.4	ADDRESSING MULTIPLE SLAVES	18	15.2	PACKAGE CODES	41
5	REGISTER MAP	19	16	DESIGNED FOR SUSTAINABILITY	42
5.1	GENERAL REGISTERS	20	17	TABLE OF FIGURES	42
5.2	MOTOR CONTROL	22	18	REVISION HISTORY	43
5.3	CHOPPER CONTROL REGISTERS	23	19	REFERENCES	43
6	CHOPPER OPTIONS	27			
6.1	LOAD INDICATOR FLAGS	27			
6.2	FREEWHEELING AND PASSIVE BRAKING	27			
7	SELECTING SENSE RESISTORS	28			

1 Principles of Operation

The TMC7300 low voltage motor driver is intended for battery-operated, space- and standby-power-critical driver applications. It is optimized for DC motor control, as well as control of other magnetic actuators or lamp and LED driving. Optionally the driver supplies four protected half-bridges for direct control by four input signals. A highly efficient power stage, boosted by an internal charge pump for best in-class RDSon resistance, provides high motor current from a tiny package even at low supply voltages. With this, dual AA batteries can be drained down to typically 2.0V (voltage must not drop below 1.8V, provide sufficient supply buffer capacitors).

The TMC7300 requires just a few control pins on its tiny package, as full control is possible via UART interface.

Protection and diagnostic features support robust and reliable operation. A simple-to-use 8 bit UART interface opens up more tuning and control options. Industries' most advanced low voltage motor driver family upgrades designs to efficient and reliable operation for cost-effective and highly competitive solutions.

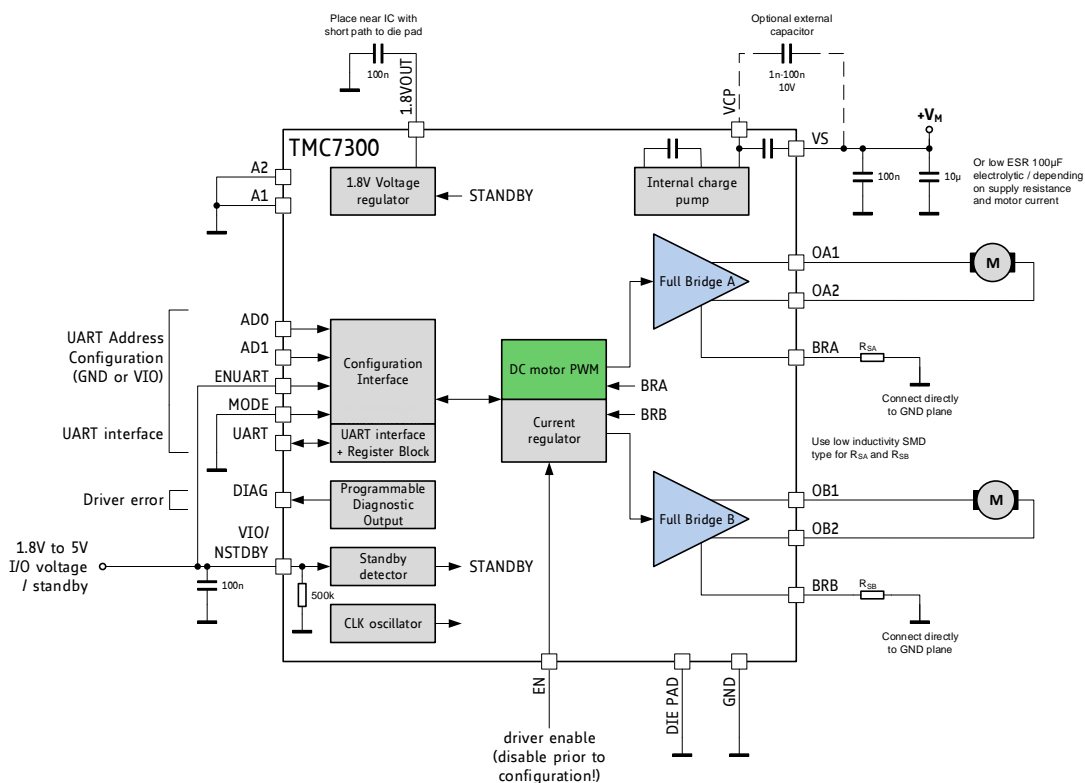

Figure 1.1 TMC7300 basic application block diagram for two DC motors

MODES OF OPERATION:

OPTION 1: DC-Motor Driver with Full Diagnostics and Control

This mode allows operation of two DC motors, or a single motor with double current.

Options (label UART):

- + Full control over motor velocity and direction by setting PWM voltage for each motor
- + Control motor torque limit for both motors, by setting a common current limit
- + Use current limit to safely avoid battery overload during acceleration or when motor is blocked
- + Detailed diagnostics and thermal management
- + Passive braking and freewheeling for flexible, lowest power stop modes



Access to multiple driver ICs is possible using 4 different address settings or via an analog multiplexer IC.

UART INTERFACE FOR CONTROL OF 2 DC MOTORS

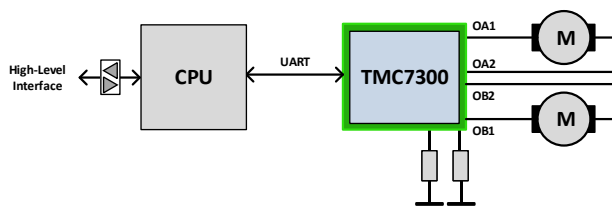

UART INTERFACE FOR CONTROL OF 1 DC MOTOR (UP TO 2.4A)

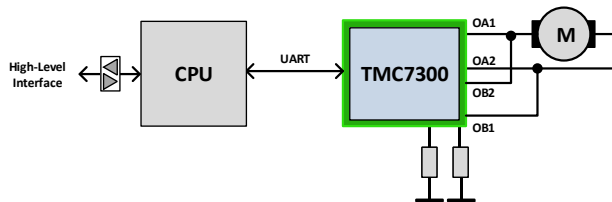

Figure 1.2 UART controlled single or Dual DC motor driver

OPTION 2: 4 Half Bridge Peripheral Driver

This mode uses the power stage to drive inductive or resistive loads. A single-shunt measurement can be realized, using the bridge foot point connections to add a sense resistor. The TMC7300 protects the power stage against overload. An external microcontroller controls each half bridge using a single input / optionally a common high-side PWM.

4 HALF BRIDGE PERIPHERAL DRIVERS

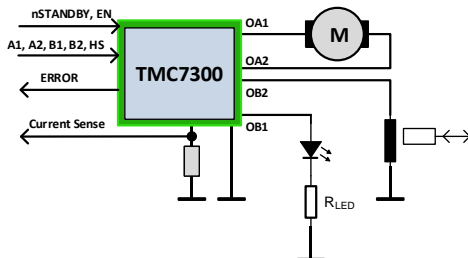

Figure 1.3 Peripheral Power Driver

1.1 Control Interfaces

The TMC7300 supports both, discrete control lines for basic operation and a UART based single wire interface with CRC checking.



1.1.1 UART Interface

The single wire interface allows unidirectional operation (for parameter setting only), or bi-directional operation for full control and diagnostics. It can be driven by any standard microcontroller UART or even by bit banging in software. Baud rates from 9600 Baud to 500k Baud may be used. No baud rate configuration is required, as the TMC7300 automatically adapts to the masters' baud rate. The frame format is identical to the intelligent TRINAMIC controller & driver ICs TMC51XX and TMC22XX. A CRC checksum allows data transmission over longer distance. For fixed initialization sequences, store the data including CRC into the μ C, thus consuming only a few 100 bytes of code for a full initialization. CRC may be ignored during read access, if not desired. This makes CRC use an optional feature! The IC has a fixed address selected by 2 pins. Multiple drivers can be programmed in parallel by tying

together all interface pins, in case no read access is required. An optional addressing can be provided by analog multiplexers, like 74HC4066.

From a software point of view the TMC7300 is a peripheral with a number of control and status registers. Most of them can either be written only or are read only. Some of the registers allow both, read and write access. In case read-modify-write access is desired for a write only register, a shadow register can be realized in master software.

1.2 Moving and Controlling the Motor



1.2.1 PWM control

The motor is operated by an internal PWM generator. The PWM acts like a dedicated voltage source for the motor. E.g. a 50% duty cycle will let the motor turn like with 50% of the supply voltage. A negated duty cycle will turn the motor in the opposite direction. This way, direction and velocity can be controlled like with a programmable power source. By slowly increasing / decreasing the duty cycle, the motor can be softly accelerated and decelerated.

1.2.2 Internal Current Limiter

When a DC-motor is mechanical loaded, its current increases. Therefore, a current limit allows limitation of motor torque. At the same time, the power source, e.g. a dual AA battery with a certain internal resistance is protected against voltage drop due to overload. This feature especially is helpful when moving the motor to a mechanical obstacle. The action of the current limiter can be read back via the interface.



1.3 Mechanical Load Sensing

When a DC-motor is mechanical loaded, its current increases. Therefore, a current limit allows limitation of motor torque. The TMC7300 reports back, when this load limit is achieved. This feature especially is helpful when moving the motor to a mechanical obstacle.

1.4 Protection and Diagnostics

By adapting the sense resistor to the desired maximum current, a sensitive protection of the respective half bridge is reached. In case the voltage drop across the sense resistor plus internal Power MOSFET exceeds roughly 1V, the power stage becomes disabled and the error is reported via the interface, or via the DIAG output.

2 Pin Assignments

The TMC7300 comes in a tiny package in order to fit miniaturized devices. For the ease of use, pinning is shown separately for all four function-modes.

2.1 Package Outline TMC7300 (UART mode)

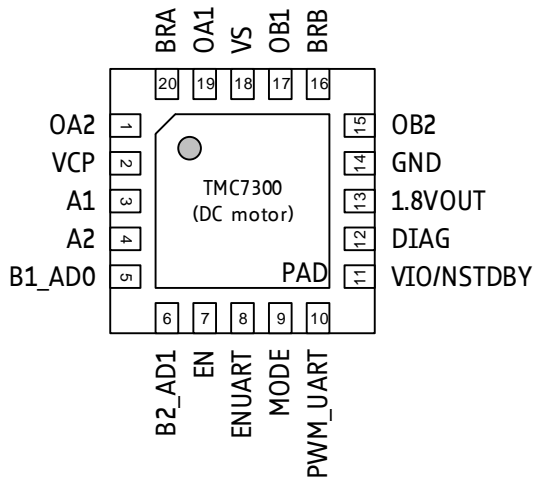

Figure 2.1 TMC7300 Pinning Top View Stepper Driver – QFN20, 3x3mm², 0.4mm pitch

2.2 Signal Descriptions / UART mode

Pin	Number	Type	Function
OA2	1		DC motor 1 output 2
VCP	2		Charge pump voltage. Optionally tie to VS using 1nF to 100nF capacitor. May be left unconnected in stepper mode.
A1	3	DI	A1 input not used in UART mode (tie to GND or VCC_IO)
A2	4	DI	A2 input not used in UART mode (tie to GND or VCC_IO)
B1_ADO	5	DI	Selection of UART Address 0...3 (ADO=LSB, AD1=MSB)
B2_AD1	6	DI	
EN	7	DI	Enable input. The power stage becomes switched off (all motor outputs floating) when this pin becomes driven to a low level. Also used to clear error flags.
ENUART	8	DI	Mode selection input. ENUART, MODE: 01: 4 Halfbridge 10: UART enabled (CLK, TST input in factory test mode)
MODE	9	DI	
PWM_UART	10	DIO	UART Input/Output.
VIO/NSTDBY	11		1.8V to 5V IO supply voltage for all digital pins. IC goes to standby mode and resets, when this pin is pulled to GND.
DIAG	12	DO	Diagnostic output. High level upon driver error or stall. Reset by EN=low.
1.8VOUT	13		Output of internal 1.8V regulator. Attach 100nF ceramic capacitor to GND near to pin for best performance. Provide the shortest possible loop to the GND pad.
GND	14		GND. Connect to GND plane near pin.
OB2	15		DC motor 2 output 2
BRB	16		Sense resistor connection for coil B or DC motor 2. Place sense resistor to GND near pin.
OB1	17		DC motor 2 output 1

Pin	Number	Type	Function
VS	18		Motor supply voltage. Provide filtering capacity >10 μ F near pin with shortest possible loop to GND pad.
OA1	19		DC motor 1 output 2
BRA	20		Sense resistor connection for coil A or DC motor 1. Place sense resistor to GND near pin.
Exposed die pad	-		Connect the exposed die pad to a GND plane. Provide as many as possible vias for heat transfer to GND plane.

2.3 Package Outline / Halfbridge mode

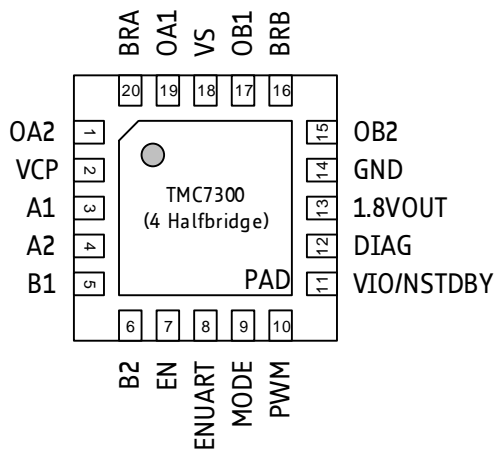

Figure 2.2 TMC7300 Pinning Top View Stepper Driver – QFN20, 3x3mm², 0.4mm pitch

2.4 Signal Descriptions / Halfbridge mode

Pin	Number	Type	Function
OA2	1		Bridge A output 2
VCP	2		Charge pump voltage. Optionally tie to VS using 1nF to 100nF capacitor. May be left unconnected if maximum 2 pins change at a time.
A1	3	DI	Bridge A output 1 polarity
A2	4	DI	Bridge A output 2 polarity
B1	5	DI	Bridge B output 1 polarity
B2	6	DI	Bridge B output 2 polarity
EN	7	DI	Enable input. The power stage becomes switched off (all motor outputs floating) when this pin becomes driven to a low level. Also used to release driver after fault shutdown.
ENUART	8	DI	tie to GND
MODE	9	DI	tie to VIO
PWM	10	DI	Common PWM for high-side drivers. Tie high to enable high-side drivers as controlled by A and B inputs. Influences high-side driver, only.
VIO/NSTDBY	11		1.8V to 5V IO supply voltage for all digital pins. IC goes to standby mode and resets, when this pin is pulled to GND.
DIAG	12	DO	Diagnostic output. High level upon driver error. Reset by EN=low.
1.8VOUT	13		Output of internal 1.8V regulator. Attach 100nF ceramic capacitor to GND near to pin for best performance. Provide the shortest possible loop to the GND pad.

Pin	Number	Type	Function
GND	14		GND. Connect to GND plane near pin.
OB2	15		Bridge B output 2
BRB	16		Foot point of bridge B. Connect to GND directly, or via a sense resistor, if external current measurement is desired.
OB1	17		Bridge B output 1
VS	18		Bridge supply voltage. Provide filtering capacity $>10\mu\text{F}$ near pin with shortest possible loop to GND pad.
OA1	19		Bridge A output 1
BRA	20		Foot point of bridge A. Connect to GND directly, or via a sense resistor.
Exposed die pad	-		Connect the exposed die pad to a GND plane. Provide as many as possible vias for heat transfer to GND plane.

3 Sample Circuits

The sample circuits show the connection of external components in different operation and supply modes. The connection of the bus interface and further digital signals is left out for clarity. The TMC7300 is configured for different application modes by two pins, as well as by settings available via the UART interface.

3.1 DC Motor Operation

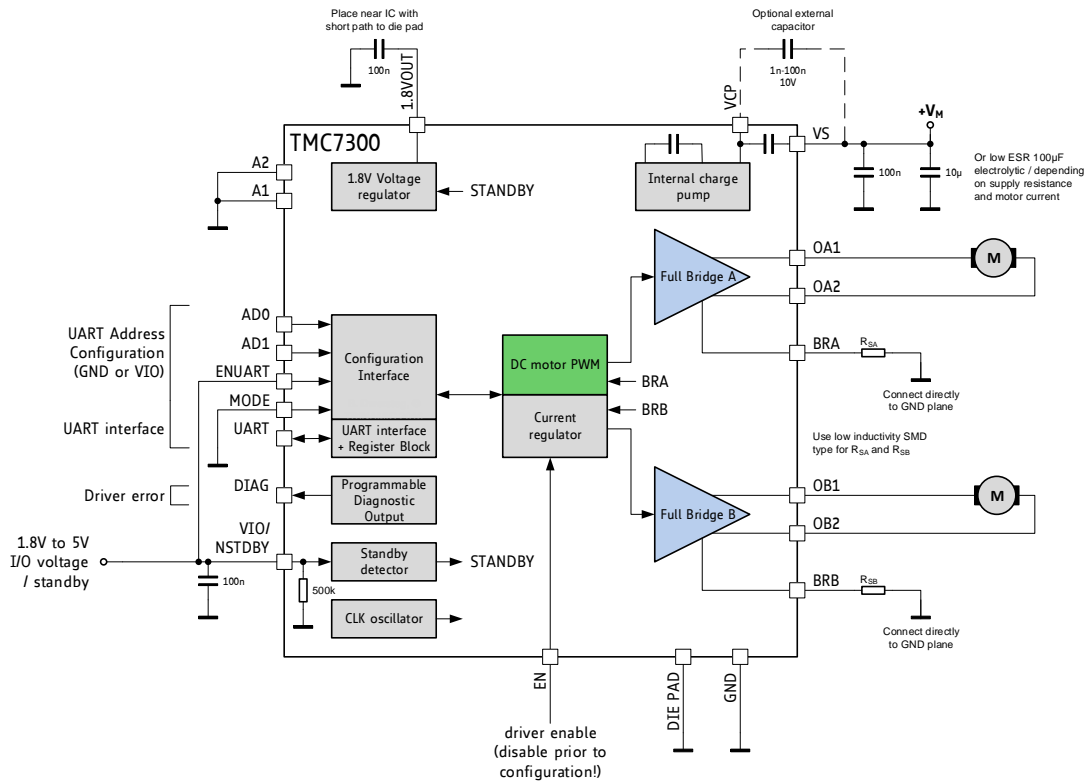

Figure 3.1 Operation of two DC-Motors for 1.8V to 11V supply

The standard application circuit uses a minimum set of additional components to operate one or two DC motors. Each one sense resistor sets the motor current limit. See chapter 7 to choose the right sense resistor value. Take care to keep power supply ripple due to chopper operation at a few 100mV, max., especially when low voltage operation is desired. Use ceramic, or low ESR capacitors for filtering the power supply. The capacitors need to cope with the current ripple caused by chopper operation. A minimum capacity of 100 μ F electrolytic, or a 10 μ F ceramic capacitor near the driver is recommended to keep ripple low. Actual demand will depend on the internal power supply resistance and the desired motor current. VCC_IO can be supplied from a separate supply, e.g. a 3.3V regulator, or be driven by a microcontroller port pin. AD0 and AD1 set the UART address. Ensure, that the EN pin is driven by the microcontroller in order to disable the motor prior to initialization! Apply a pulldown resistor for EN to keep it low during power-up.

Basic layout and component hints

Place sense resistors and all filter capacitors as close as possible to the related IC pins. Use a solid common GND for all GND connections, also for sense resistor GND. Connect 1.8VOUT filtering capacitor directly to 1.8VOUT and the GND pin. See layout hints for more details. Low ESR electrolytic capacitors are recommended for VS filtering unless supply resistance is very low.

Attention

Power up with EN-pin low. Set `GCONF.pwm_direct` prior to enabling the driver via EN-pin. Otherwise the motor will run directly after power-up.

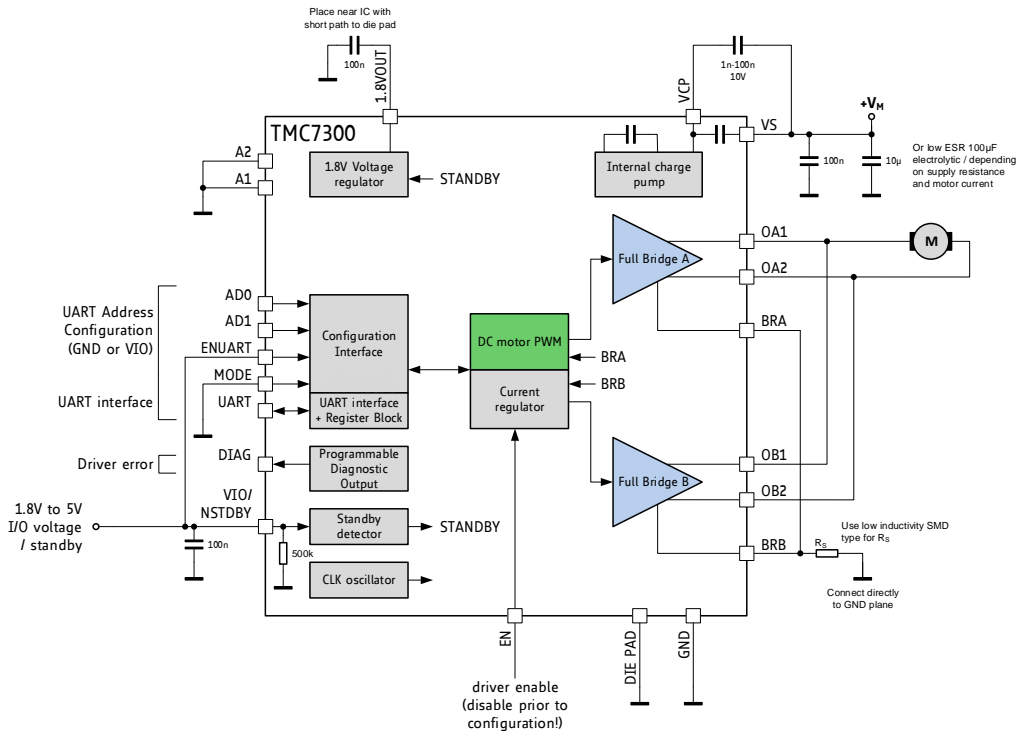

Figure 3.2 Operation of a single DC-Motor (double current)

A single DC-motor can be operated at double current (up to 2.4A), by paralleling both power-stages. Before operating the motor, the IC has to be switched to parallel mode, because default setting will cause a short circuit between the bridges and a high current flow, which will trigger overcurrent protection. Therefore ensure, that the EN pin is driven by the microcontroller in order to disable the motor prior to initialization. Apply a pull-down resistor for EN additionally to ensure power-up with a low level.

Attention

For parallel operation, power up with EN-pin low. Set *GCONF.par_mode* in order to force identical drive signals prior to enabling the driver via EN-pin. In this mode, a capacitor is required on pin VCP.

3.2 Halfbridge Driver Mode

Halfbridge driver mode offers four separate half-bridges to individually drive and control resistive and inductive loads, like LEDs, solenoids, etc. In case a current measurement is desired, each two halfbridges allow adding a foot point shunt resistor. Keep voltage drop in this resistor to maximum 400mV for normal operation. A common high-side PWM input allows switching off all high-side drivers at the same time. It does not influence drivers, where the low-side is on. If more than two drivers are switched at the same time, a capacitor on pin VCP is recommended. The diagnostic output signals any overcurrent or overtemperature condition. The driver automatically restarts after power-up, or after cycling VIO_NSTDBY pin.

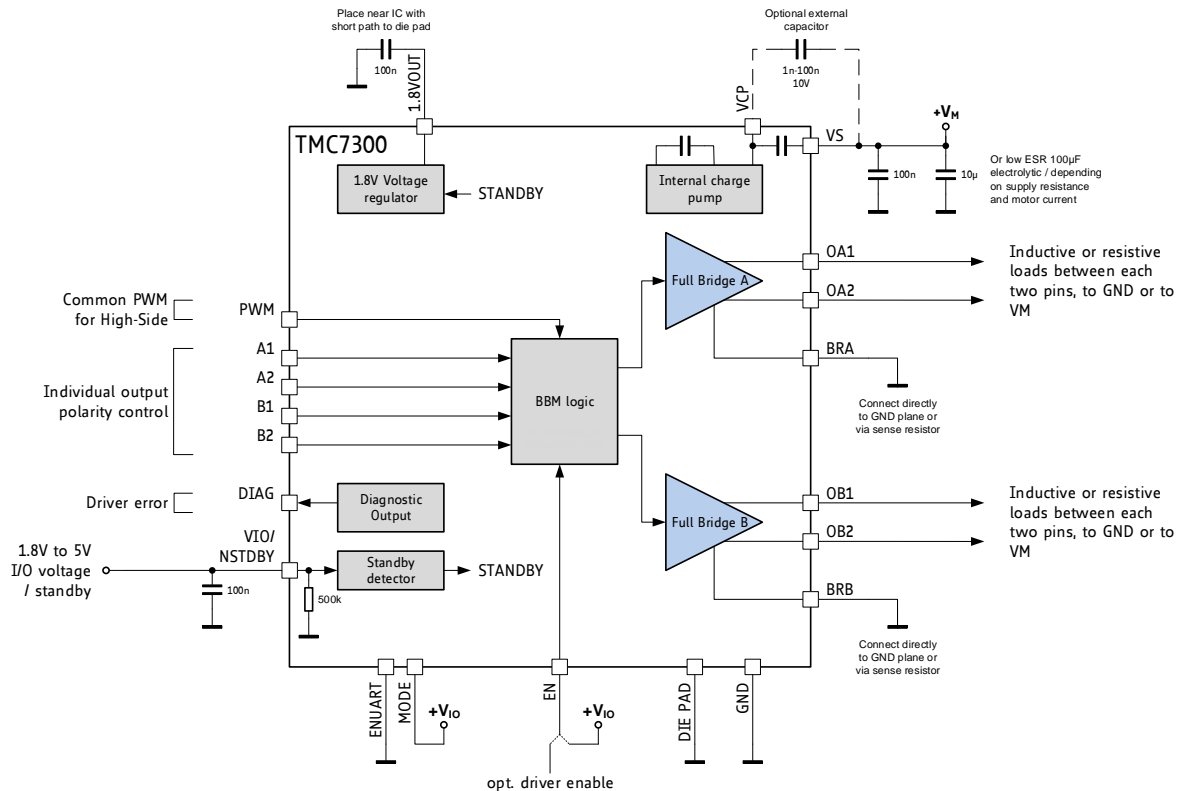

Figure 3.3 Halfbridge Driver Mode

3.3 Highly Efficient Driver

The TMC7300 integrates a highly efficient power stage, offering low R_{DSon} even at low supply voltages, due to its internal charge pump. This enables high motor current drive capability and low power dissipation for battery powered applications.

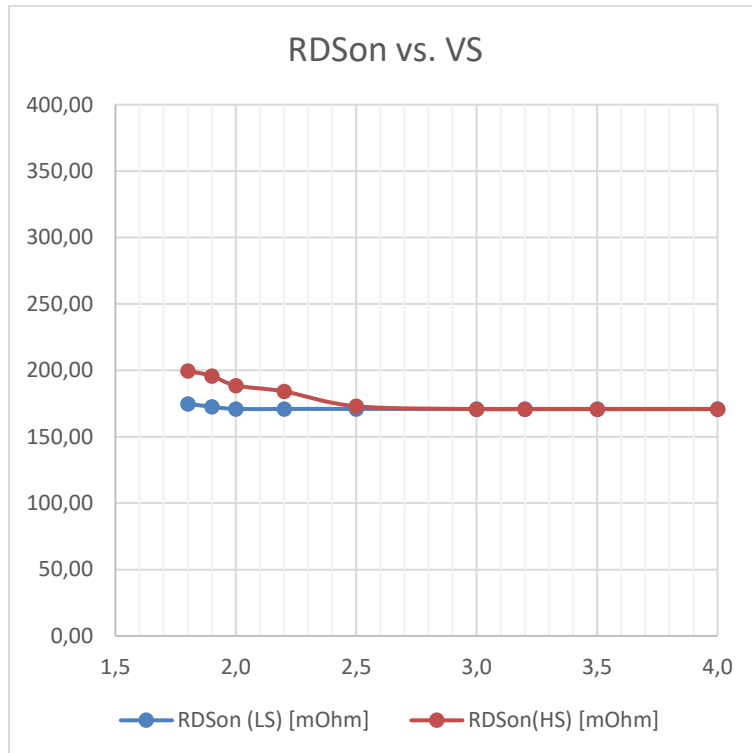

Figure 3.4 RDSon Variation over Supply Voltage

When operating at a high motor current, the driver power dissipation due to MOSFET switch on-resistance significantly heats up the driver. This power dissipation will significantly heat up the PCB cooling infrastructure, if operated at an increased duty cycle. This in turn leads to a further increase of driver temperature. An increase of temperature by about 100°C increases MOSFET resistance by roughly 50%. This is a typical behavior of MOSFET switches. Therefore, under high duty cycle, high load conditions, thermal characteristics have to be carefully taken into account, especially when increased environment temperatures are to be supported. Refer the thermal characteristics and the layout hints for more information. As a thumb rule, thermal properties of the PCB design become critical for the tiny QFN 3mm x 3mm package at or above 0.8A mean motor current for increased periods of time. For currents above 0.8A, a 4-layer PCB layout with 5 via contact of the die attach pad to the GND plane is required. Keep in mind that resistive power dissipation raises with the square of the motor current. On the other hand, this means that a small reduction of motor current significantly saves heat dissipation and energy.

Pay special attention to good thermal properties of your PCB layout, when going for 0.8A mean current or more.

3.4 Low Power Standby

Battery powered applications, as well as mains powered applications conforming to EU energy saving regulations, often require a standby mode, where the power-supply remains on. Current consumption in this mode must be minimized. Control near zero power TMC7300 standby operation by switching off the I/O supply voltage on VIO_NSTDBY pin. At the same time make sure, that no digital input pin is at a high level. An input level above VIO_NSTDBY would hinder pulling down VIO_NSTDBY, due to the ESD protection diodes in each digital I/O pin. These diodes clamp each input to a level between GND and the IO supply voltage VIO_NSTDBY. Therefore, stop the motor first, and allow sufficient time for the motor to come to a standstill, pull the enable input EN low, and also all other input pins, to switch off the motor completely before switching off VIO voltage. All driver registers are reset to their power-up defaults after leaving standby mode. See Figure 3.5.

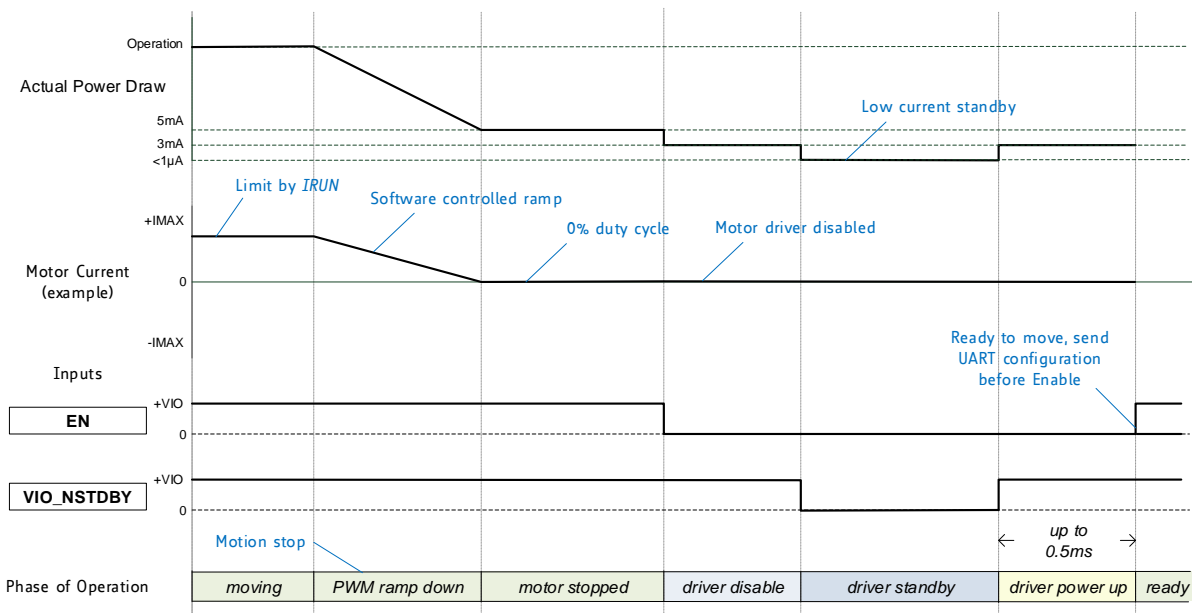

Figure 3.5 Switching to Standby and Back On

3.5 Very Low I/O Voltage Operation

In cases, where an I/O voltage of 1.8V (or even lower, due to tolerance) is to be used, the VIO undervoltage threshold level might be too high, to safely release the TMC7300 from reset state. A simple way to avoid the need for an additional I/O voltage regulator (e.g. 2V type), is to use the internal 1.8V regulator to self-supply the TMC7300 VIO pin. In order to allow power-up, the voltage on pin at VIO/NSTDBY has to be forced to min. 1.4V. In order to go back to low power standby, pull it down to less than 0.6V. A PNP transistor gives a low resistive switch to supply VIO.

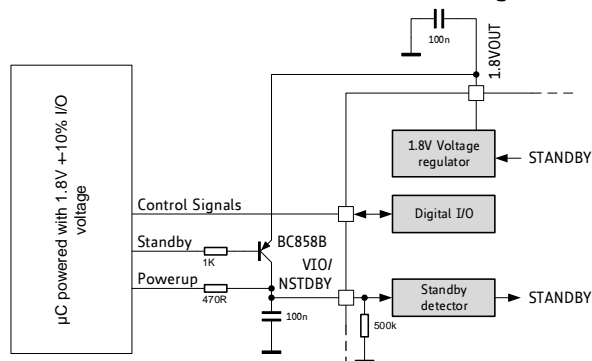

Figure 3.6 Additional Circuit for I/O voltage <1.80V



4 UART Single Wire Interface

The UART single wire interface allows control of the TMC7300 with any microcontroller UART. It shares transmit and receive line like an RS485 based interface. Data transmission is secured using a cyclic redundancy check, so that increased interface distances (e.g. over cables between two PCBs) can be bridged without danger of wrong or missed commands even in the event of electro-magnetic disturbance. The automatic baud rate detection makes this interface easy to use.

4.1 Datagram Structure

4.1.1 Write Access

UART WRITE ACCESS DATAGRAM STRUCTURE																			
each byte is LSB...MSB, highest byte transmitted first																			
0 ... 63																			
sync + reserved							8 bit slave address			RW + 7 bit register addr.			32 bit data			CRC			
0...7							8...15			16...23			24...55			56...63			
1	0	1	0	Reserved (don't cares but included in CRC)			<i>SLAVEADDR</i> =(MS2, MS1)			register address	1		data bytes 3, 2, 1, 0 (high to low byte)			CRC			
0	1	2	3	4	5	6	7	8	..	15	16	..	23	24	..	55	56	..	63

A sync nibble precedes each transmission to and from the TMC7300 and is embedded into the first transmitted byte, followed by an addressing byte (0 to 3, selected by pins MS1 (LSB) and MS2 for TMC7300). Each transmission allows a synchronization of the internal baud rate divider to the master clock. The actual baud rate is adapted and variations of the internal clock frequency are compensated. Thus, the baud rate can be freely chosen within the valid range. Each transmitted byte starts with a start bit (logic 0, low level on UART pin) and ends with a stop bit (logic 1, high level on UART pin). The bit time is calculated by measuring the time from the beginning of start bit (1 to 0 transition) to the end of the sync frame (1 to 0 transition from bit 2 to bit 3). All data is transmitted bitwise. The 32 bit data words are transmitted with the highest byte first.

A minimum baud rate of 9000 baud is permissible, assuming maximum clock frequency (worst case for low baud rate). Maximum baud rate is $f_{CLK}/16$ due to the required stability of the baud clock.

The slave address *SLAVEADDR* is selected by MS1 (bit 0) and MS2 (bit 1) in the range 0 to 3. Bit 7 of the register address identifies a Read (0) or a Write (1) access. Example: Address 0x10 is changed to 0x90 for a write access.

The communication becomes reset if a pause time of longer than 63 bit times between the start bits of two successive bytes occurs. This timing is based on the last correctly received datagram. In this case, the transmission needs to be restarted after a failure recovery time of minimum 12 bit times of bus idle time. This scheme allows the master to reset communication in case of transmission errors. Any pulse on an idle data line below 16 clock cycles will be treated as a glitch and leads to a timeout of 12 bit times, for which the data line must be idle. Other errors like wrong CRC are also treated the same way. This allows a safe re-synchronization of the transmission after any error conditions. Remark, that due to this mechanism an abrupt reduction of the baud rate to less than 15 percent of the previous value is not possible.

Each accepted write datagram becomes acknowledged by the receiver by incrementing an internal cyclic datagram counter (8 bit). Reading out the datagram counter allows the master to check the success of an initialization sequence or single write accesses. Read accesses do not modify the counter.

The UART line must be logic high during idle state.

4.1.2 Read Access

UART READ ACCESS REQUEST DATAGRAM STRUCTURE																	
each byte is LSB...MSB, highest byte transmitted first																	
sync + reserved					8 bit slave address				RW + 7 bit register address				CRC				
0...7					8...15				16...23				24...31				
1	0	1	0	Reserved (don't cares but included in CRC)				SLAVEADDR=(MS2,MS1)				register address		0	CRC		
0	1	2	3	4	5	6	7	8	:	15	16	:	23	24	:	31	

The read access request datagram structure is identical to the write access datagram structure, but uses a lower number of user bits. Its function is the addressing of the slave and the transmission of the desired register address for the read access. The TMC2300 responds with the same baud rate as the master uses for the read request.

In order to ensure a clean bus transition from the master to the slave, the TMC2300 does not immediately send the reply to a read access, but it uses a programmable delay time after which the first reply byte becomes sent following a read request. This delay time can be set in multiples of eight bit times using *SENDDelay* time setting (default=8 bit times) according to the needs of the master.

UART READ ACCESS REPLY DATAGRAM STRUCTURE																			
each byte is LSB...MSB, highest byte transmitted first																			
0 63																			
sync + reserved					8 bit master address				RW + 7 bit register addr.		32 bit data				CRC				
0...7					8...15				16...23		24...55				56...63				
1	0	1	0	reserved (0)				0xFF		register address	0	data bytes 3, 2, 1, 0 (high to low byte)				CRC			
0	1	2	3	4	5	6	7	8	:	15	16	:	23	24	:	55	56	:	63

The read response is sent to the master using address code %11111111. The transmitter becomes switched inactive four bit times after the last bit is sent.

Address %11111111 is reserved for read access replies going to the master.

Hint

Find an example for generating read and write datagrams in the TMC2300 calculation sheet.

4.2 CRC Calculation

An 8 bit CRC polynomial is used for checking both read and write access. It allows detection of up to eight single bit errors. The CRC8-ATM polynomial with an initial value of zero is applied LSB to MSB, including the sync- and addressing byte. The sync nibble is assumed to always be correct. The TMC7300 responds only to correctly transmitted datagrams containing its own slave address. It increases its datagram counter for each correctly received write access datagram.

$$CRC = x^8 + x^2 + x^1 + x^0$$

SERIAL CALCULATION EXAMPLE

`CRC = (CRC << 1) OR (CRC.7 XOR CRC.1 XOR CRC.0 XOR [new incoming bit])`

C-CODE EXAMPLE FOR CRC CALCULATION

```
void swuart_calcCRC(UCHAR* datagram, UCHAR datagramLength)
{
    int i,j;
    UCHAR* crc = datagram + (datagramLength-1); // CRC located in last byte of message
    UCHAR currentByte;

    *crc = 0;
    for (i=0; i<(datagramLength-1); i++) { // Execute for all bytes of a message
        currentByte = datagram[i]; // Retrieve a byte to be sent from Array
        for (j=0; j<8; j++) {
            if ((*crc >> 7) ^ (currentByte&0x01)) // update CRC based result of XOR operation
            {
                *crc = (*crc << 1) ^ 0x07;
            }
            else
            {
                *crc = (*crc << 1);
            }
            currentByte = currentByte >> 1;
        } // for CRC bit
    } // for message byte
}
```

4.3 UART Signals

The UART interface on the TMC7300 uses a single bi-direction pin:

UART INTERFACE SIGNAL	
UART	Non-inverted data input and output. I/O with Schmitt Trigger and VCC_IO level.
AD0	IC UART address bit 0 (LSB)
AD1	IC UART address bit 1

The IC checks PDN_UART for correctly received datagrams with its own address continuously. It adapts to the baud rate based on the sync nibble, as described before. In case of a read access, it switches on its output drivers and sends its response using the same baud rate. The output becomes switched off four bit times after transfer of the last stop bit.

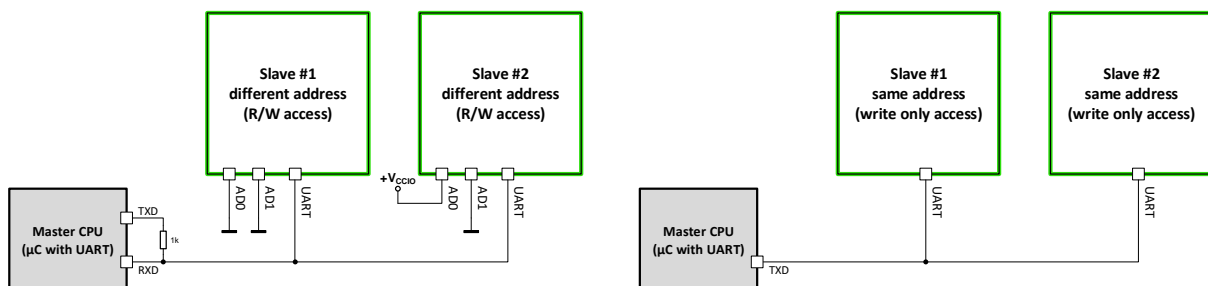

Figure 4.1 Attaching the TMC7300 to a microcontroller UART

4.4 Addressing Multiple Slaves

WRITE ONLY ACCESS

If read access is not used, and all slaves are to be programmed with the same initialization values, no addressing is required. All slaves can be programmed in parallel like a single device (Figure 4.1.).

ADDRESSING MULTIPLE SLAVES

As the TMC7300 uses has a limited number of UART addresses, in principle only up to four ICs can be accessed per UART interface channel. Adding analog switches allows separated access to individual ICs. This scheme is similar to an SPI bus with individual slave select lines (Figure 4.2).

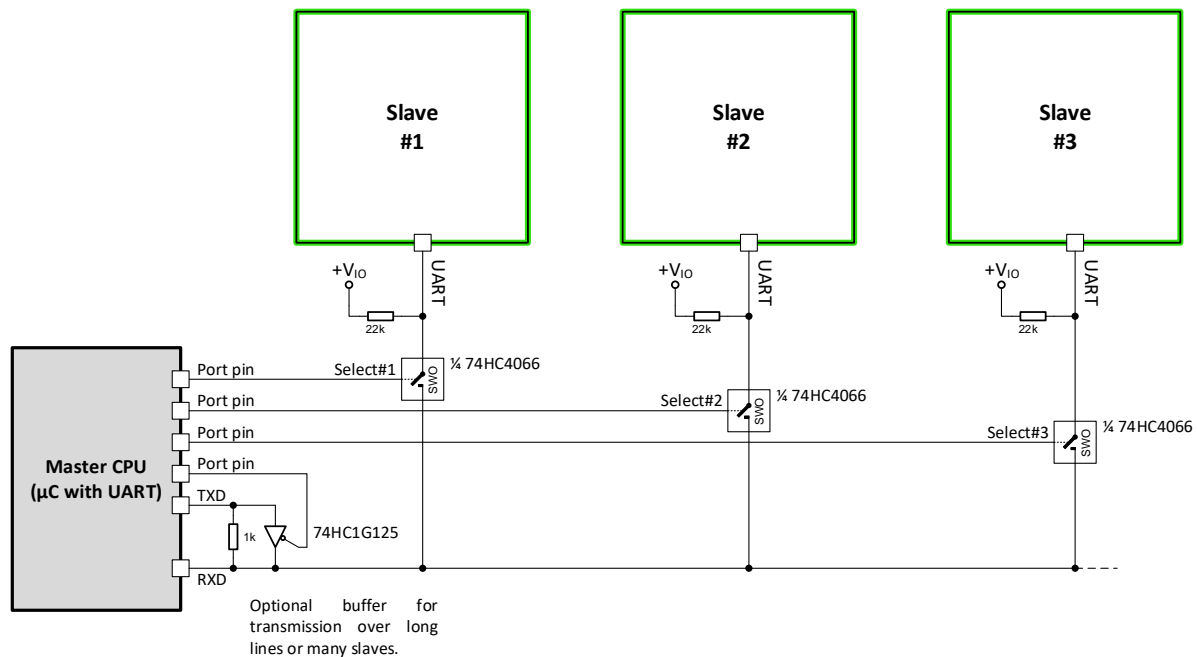

Figure 4.2 Addressing multiple TMC7300 via single wire interface using analog switches

PROCEED AS FOLLOWS TO CONTROL MULTIPLE SLAVES:

- Set the UART to 8 bits, no parity. Select a baud rate safely within the valid range. At 250kBaund, a write access transmission requires $320\mu\text{s}$ ($=8 \text{ Bytes} * (8+2) \text{ bits} * 4\mu\text{s}$).
- Before starting an access, activate the select pin going to the analog switch by setting it high. All other slaves select lines shall be off, unless a broadcast is desired.
- When using the optional buffer, set TMC7300 transmission send delay to an appropriate value allowing the μC to switch off the buffer before receiving reply data.
- To start a transmission, activate the TXD line buffer by setting the control pin low.
- When sending a read access request, switch off the buffer after transmission of the last stop bit is finished.
- Take into account, that all transmitted data also is received by the RXD input.

5 Register Map



This chapter gives an overview of the complete register set. Some of the registers bundling a number of single bits are detailed in extra tables. The functional practical application of the settings is detailed in dedicated chapters.

Note

- *Reset default:* All registers become reset to 0 upon power up, unless otherwise noted.
- Add 0x80 to the address **Addr** for write accesses!

NOTATION OF HEXADECIMAL AND BINARY NUMBERS

0x	precedes a hexadecimal number, e.g. 0x04
%	precedes a multi-bit binary number, e.g. %100

NOTATION OF R/W FIELD

R	Read only
W	Write only
R/W	Read- and writable register
R+C	Clear upon read

OVERVIEW REGISTER MAPPING

REGISTER	DESCRIPTION
General Configuration Registers	These registers contain <ul style="list-style-type: none"> - global configuration - global status flags - interface configuration
Chopper Register Set	This register set offers registers for <ul style="list-style-type: none"> - chopper settings, e.g. frequency - passive braking and freewheeling options - driver diagnostics - driver enable / disable
Motor Control Registers	Register set for actual control of motor operation

5.1 General Registers

GENERAL CONFIGURATION REGISTERS (0x00...0x0F)																						
R/W	Addr	n	Register	Description / bit names																		
RW	0x00	10	GCONF	<table border="1"> <thead> <tr> <th>Bit</th> <th>GCONF – Global configuration flags</th> </tr> </thead> <tbody> <tr> <td>0</td> <td> <i>PWM_direct</i> (Reset default=0) 0: Do not use this mode. 1: Normal DC-motor operation <i>Attention:</i> Do not enable driver prior to setting this flag. Motors 1 would start running. </td> </tr> <tr> <td>1</td> <td> <i>extcap</i> (Reset default=0) 0: Operation without external capacitor on VCP. 1: External capacitor available. No switching delays. </td> </tr> <tr> <td>2</td> <td> <i>par_mode</i> (Reset default=0) 0: normal operation (dual motor) 1: Single DC-motor operation: Parallel operation for single motor. Bridge OA1 and OB1, OA2 and OB2 output identical signals. Control is by bridge A, only. Externally bridge the outputs and the sense resistor connection. <i>Attention:</i> Do not enable driver prior to setting this flag, if outputs are bridged! </td> </tr> <tr> <td>3</td> <td>reserved / set to 0</td> </tr> <tr> <td>4</td> <td>reserved / set to 0</td> </tr> <tr> <td>5</td> <td>reserved / set to 0</td> </tr> <tr> <td>6</td> <td>reserved / set to 0</td> </tr> <tr> <td>7</td> <td> <i>test_mode</i> 0: Normal operation 1: Enable analog test output on pin DIR <i>IHOLD</i>[1..0] selects the function of DIR: 0...1: T120, DAC <i>Attention: Not for user, set to 0 for normal operation!</i> </td> </tr> </tbody> </table>	Bit	GCONF – Global configuration flags	0	<i>PWM_direct</i> (Reset default=0) 0: Do not use this mode. 1: Normal DC-motor operation <i>Attention:</i> Do not enable driver prior to setting this flag. Motors 1 would start running.	1	<i>extcap</i> (Reset default=0) 0: Operation without external capacitor on VCP. 1: External capacitor available. No switching delays.	2	<i>par_mode</i> (Reset default=0) 0: normal operation (dual motor) 1: Single DC-motor operation: Parallel operation for single motor. Bridge OA1 and OB1, OA2 and OB2 output identical signals. Control is by bridge A, only. Externally bridge the outputs and the sense resistor connection. <i>Attention:</i> Do not enable driver prior to setting this flag, if outputs are bridged!	3	reserved / set to 0	4	reserved / set to 0	5	reserved / set to 0	6	reserved / set to 0	7	<i>test_mode</i> 0: Normal operation 1: Enable analog test output on pin DIR <i>IHOLD</i> [1..0] selects the function of DIR: 0...1: T120, DAC <i>Attention: Not for user, set to 0 for normal operation!</i>
				Bit	GCONF – Global configuration flags																	
				0	<i>PWM_direct</i> (Reset default=0) 0: Do not use this mode. 1: Normal DC-motor operation <i>Attention:</i> Do not enable driver prior to setting this flag. Motors 1 would start running.																	
				1	<i>extcap</i> (Reset default=0) 0: Operation without external capacitor on VCP. 1: External capacitor available. No switching delays.																	
				2	<i>par_mode</i> (Reset default=0) 0: normal operation (dual motor) 1: Single DC-motor operation: Parallel operation for single motor. Bridge OA1 and OB1, OA2 and OB2 output identical signals. Control is by bridge A, only. Externally bridge the outputs and the sense resistor connection. <i>Attention:</i> Do not enable driver prior to setting this flag, if outputs are bridged!																	
				3	reserved / set to 0																	
				4	reserved / set to 0																	
				5	reserved / set to 0																	
6	reserved / set to 0																					
7	<i>test_mode</i> 0: Normal operation 1: Enable analog test output on pin DIR <i>IHOLD</i> [1..0] selects the function of DIR: 0...1: T120, DAC <i>Attention: Not for user, set to 0 for normal operation!</i>																					
R+ WC	0x01	3	GSTAT	<table border="1"> <thead> <tr> <th>Bit</th> <th>GSTAT – Global status flags (Re-Write with '1' bit to clear respective flags)</th> </tr> </thead> <tbody> <tr> <td>0</td> <td> <i>reset</i> 1: Indicates that the IC has been reset since the last read access to GSTAT. All registers have been cleared to reset values. </td> </tr> <tr> <td>1</td> <td> <i>drv_err</i> 1: Indicates, that the driver has been shut down due to overtemperature or short circuit detection since the last read access. Read DRV_STATUS for details. The flag can only be cleared when all error conditions are cleared. </td> </tr> <tr> <td>2</td> <td> <i>u3v5</i> 1: Actual state of the supply voltage comparator. A high value means that the voltage sinks below 3.5V. This flag is not latched and thus does not need to be cleared. </td> </tr> </tbody> </table>	Bit	GSTAT – Global status flags (Re-Write with '1' bit to clear respective flags)	0	<i>reset</i> 1: Indicates that the IC has been reset since the last read access to GSTAT. All registers have been cleared to reset values.	1	<i>drv_err</i> 1: Indicates, that the driver has been shut down due to overtemperature or short circuit detection since the last read access. Read DRV_STATUS for details. The flag can only be cleared when all error conditions are cleared.	2	<i>u3v5</i> 1: Actual state of the supply voltage comparator. A high value means that the voltage sinks below 3.5V. This flag is not latched and thus does not need to be cleared.										
				Bit	GSTAT – Global status flags (Re-Write with '1' bit to clear respective flags)																	
				0	<i>reset</i> 1: Indicates that the IC has been reset since the last read access to GSTAT. All registers have been cleared to reset values.																	
1	<i>drv_err</i> 1: Indicates, that the driver has been shut down due to overtemperature or short circuit detection since the last read access. Read DRV_STATUS for details. The flag can only be cleared when all error conditions are cleared.																					
2	<i>u3v5</i> 1: Actual state of the supply voltage comparator. A high value means that the voltage sinks below 3.5V. This flag is not latched and thus does not need to be cleared.																					
R	0x02	8	IFCNT	Interface transmission counter. This register becomes incremented with each successful UART interface write access. Read out to check the serial transmission for lost data. Read accesses do not change the content. The counter wraps around from 255 to 0.																		
W	0x03	4	SLAVECONF	<table border="1"> <thead> <tr> <th>Bit</th> <th>SLAVECONF</th> </tr> </thead> </table>	Bit	SLAVECONF																
Bit	SLAVECONF																					

GENERAL CONFIGURATION REGISTERS (0x00...0x0F)																																
R/W	Addr	n	Register	Description / bit names																												
				11..8 SENDDELAY for read access (time until reply is sent): 0, 1: 8 bit times 2, 3: 3*8 bit times 4, 5: 5*8 bit times 6, 7: 7*8 bit times 8, 9: 9*8 bit times 10, 11: 11*8 bit times 12, 13: 13*8 bit times 14, 15: 15*8 bit times																												
R	0x06	10 + 8	IOIN	<table border="1"> <thead> <tr> <th>Bit</th> <th>INPUT (Reads the state of all input pins available)</th> </tr> </thead> <tbody> <tr> <td>0</td> <td>EN (1=enable driver)</td> </tr> <tr> <td>1</td> <td>NSTDBY (0=standby, 1=enable)</td> </tr> <tr> <td>2</td> <td>AD0</td> </tr> <tr> <td>3</td> <td>AD1</td> </tr> <tr> <td>4</td> <td>DIAG</td> </tr> <tr> <td>5</td> <td>1: UART interface on</td> </tr> <tr> <td>6</td> <td>UART input</td> </tr> <tr> <td>7</td> <td>MODE input 0: UART controlled operation</td> </tr> <tr> <td>8</td> <td>A2</td> </tr> <tr> <td>9</td> <td>A1</td> </tr> <tr> <td>10</td> <td>COMP_A1A2 1: during LS passive braking: A1 voltage > A2 voltage</td> </tr> <tr> <td>11</td> <td>COMP_B1B2 1: during LS passive braking: B1 voltage > B2 voltage</td> </tr> <tr> <td>31.. 24</td> <td>VERSION: 0x40=first version of the IC Identical numbers mean full digital compatibility.</td> </tr> </tbody> </table>	Bit	INPUT (Reads the state of all input pins available)	0	EN (1=enable driver)	1	NSTDBY (0=standby, 1=enable)	2	AD0	3	AD1	4	DIAG	5	1: UART interface on	6	UART input	7	MODE input 0: UART controlled operation	8	A2	9	A1	10	COMP_A1A2 1: during LS passive braking: A1 voltage > A2 voltage	11	COMP_B1B2 1: during LS passive braking: B1 voltage > B2 voltage	31.. 24	VERSION: 0x40=first version of the IC Identical numbers mean full digital compatibility.
Bit	INPUT (Reads the state of all input pins available)																															
0	EN (1=enable driver)																															
1	NSTDBY (0=standby, 1=enable)																															
2	AD0																															
3	AD1																															
4	DIAG																															
5	1: UART interface on																															
6	UART input																															
7	MODE input 0: UART controlled operation																															
8	A2																															
9	A1																															
10	COMP_A1A2 1: during LS passive braking: A1 voltage > A2 voltage																															
11	COMP_B1B2 1: during LS passive braking: B1 voltage > B2 voltage																															
31.. 24	VERSION: 0x40=first version of the IC Identical numbers mean full digital compatibility.																															

5.2 Motor Control

MOTOR CONTROL REGISTER SET (0x10...0x1F)					
R/W	Addr	n	Register	Description / bit names	
W	0x10	1 +	CURRENT_ LIMIT	Bit	CURRENT_LIMIT - Driver current control
				0	<i>motorrn</i> (Reset default=1) 1: Normal motor operation 0: Enable freewheeling options. The motor becomes stopped in case freewheeling or passive braking is selected (<i>PWM_CONF</i>).
		5		12..8	<i>IRUN</i> (Reset default=31) Run current limit for both motors (0=1/32 ... 31=32/32) Set a current value to limit motor torque. Each full bridge current is individually cycle by cycle limited by <i>IRUN</i> setting. When current limiting is <i>not</i> active, <i>OLA</i> resp. <i>OLB</i> become set. <i>Hint:</i> Choose sense resistors in a way, that <i>IRUN</i> limit is 8 to 31 for best performance.
W	0x22	9 +	PWM_AB	Bit	PWM_DIRECT - Driver current control
				8..0	<i>PWM_A</i> , signed: Bridge A PWM duty cycle (-255 to +255 => -100% to +100%)
				24..16	<i>PWM_B</i> , signed: Bridge B PWM duty cycle (-255 to +255 => -100% to +100%)

5.3 Chopper Control Registers

CHOPPER CONTROL REGISTER SET (0x6C...0x7F)					
R/W	Addr	n	Register	Description / bit names	Range [Unit]
RW	0x6C	32	CHOPCONF	Chopper and driver configuration <i>See separate table!</i>	Reset default= 0x13008001
R	0x6F	32	DRV_STATUS	Driver status flags and current level read back <i>See separate table!</i>	
RW	0x70	22	PWMCONF	StealthChop PWM chopper configuration <i>See separate table!</i>	Reset default= 0xC40D1024

5.3.1 CHOPCONF – Chopper Configuration

0x6C: CHOPCONF – CHOPPER CONFIGURATION			
Bit	Name	Function	Comment
31	<i>diss2vs</i>	Low side short protection disable	0: Short protection low side is on 1: Short protection low side is disabled
30	<i>diss2g</i>	short to GND protection disable	0: Short to GND protection is on 1: Short to GND protection is disabled
29	-	reserved	set to 0 or leave unmodified
28			
27			
26			
25			
24			
23	-	reserved	set to 0 or leave unmodified
22			
21			
20			
19			
18			
17			
16	<i>tbl1</i>	TBL blank time select	%00 ... %11: Set current comparator blank time to 16, 24, 32 or 40 clocks <i>Hint: %00 or %01 is recommended for most applications (Default: %01)</i>
15	<i>tbl0</i>		
14	-	reserved	set to 0
13			
12			
11			
10			
9			
8			
7			
6			
5			
4			
3			
2			
1			
0	<i>enabledrv</i>	driver enable	1: Enable driver (<i>Default: 1, enable</i>)

5.3.2 PWMCONF – Voltage PWM Mode StealthChop

0x70: PWMCONF – VOLTAGE MODE PWM STEALTHCHOP			
Bit	Name	Function	Comment
31	-	reserved	set to 0 or leave unmodified
30			
29			
28			
27			
26			
25			
24			
23	-	reserved	set to 0
22	-	reserved	set to 0
21	<i>freewheel1</i>	Allows different standstill modes	Stand still option when motor current setting is zero (<i>I_HOLD</i> =0). %00: Normal operation (always selected with <i>motorr</i> =1) %01: Freewheeling %10: Coil shorted using LS drivers (passive braking) %11: Coil shorted using HS drivers (passive braking)
20	<i>freewheel0</i>		
19	-	reserved	set to 0 or leave unmodified
18	-	reserved	set to 0 or leave unmodified
17	<i>pwm_freq1</i>	PWM frequency selection	%00: $f_{PWM}=2/1024 f_{CLK}$ %01: $f_{PWM}=2/683 f_{CLK}$ %10: $f_{PWM}=2/512 f_{CLK}$ %11: $f_{PWM}=2/410 f_{CLK}$
16	<i>pwm_freq0</i>		
15	-	reserved	set to 0 or leave unmodified
14			
13			
12			
11			
10			
9			
8			
7	-	reserved	set to 0 or leave unmodified
6			
5			
4			
3			
2			
1			
0			

5.3.3 DRV_STATUS – Driver Status Flags

0x6F: DRV_STATUS – DRIVER STATUS FLAGS AND CURRENT LEVEL READ BACK			
Bit	Name	Function	Comment
31..10	-	0	Ignore these bits
9	<i>t150</i>	150°C comparator	1: Temperature threshold is exceeded, driver is off
8	<i>t120</i>	120°C comparator	1: Temperature prewarning threshold is exceeded
7	<i>lib</i>	load indicator phase B	1: Current for motor cannot be reached.
6	<i>lia</i>	load indicator phase A	0: Respective motor goes into current / torque limit <i>Hint:</i> This is just an informative flag. The driver takes no action upon it. False detection may occur in fast motion and standstill. Check during slow motion, only.
5	<i>s2vsb</i>	low side short indicator phase B	1: Short on low-side MOSFET detected on bridge A or B. The driver becomes disabled. The flags stay active, until the driver is disabled by software (<i>enabledrv=0</i>) or by the ENN input.
4	<i>s2vsa</i>	low side short indicator phase A	
3	<i>s2gb</i>	short to ground indicator phase B	1: Short to GND detected on bridge A or B. The driver becomes disabled. The flags stay active, until the driver is disabled by software (<i>enabledrv=0</i>) or by the ENN input.
2	<i>s2ga</i>	short to ground indicator phase A	
1	<i>ot</i>	overtemperature flag	1: The overtemperature limit has been reached. Drivers become disabled until <i>otpw</i> is also cleared due to cooling down of the IC. The overtemperature flag is common for both bridges.
0	<i>otpw</i>	overtemperature pre-warning flag	1: The overtemperature pre-warning threshold is exceeded. The overtemperature pre-warning flag is common for both bridges.



6 Chopper Options

In order to match the motor voltage or current to a certain level, the effective PWM voltage becomes scaled depending on the settings *IRUN* and *PWM_A* respectively *PWM_B*. Current limit takes over, in case the motor current exceeds the limit as programmed by *IRUN*. This way, torque is limited as desired, as well as current draw from the battery. Reaching the current limit can be used as informative event: check *lia* resp. *lib* flags.

The Chopper PWM frequency can be chosen in four steps in order to adapt the chopper frequency to the motor inductance. It balances low current ripple vs. increased dynamic power dissipation at higher frequency.

CHOICE OF PWM FREQUENCY				
Clock frequency f_{CLK}	PWM_FREQ=%00 $f_{PWM}=2/1024 f_{CLK}$	PWM_FREQ=%01 $f_{PWM}=2/683 f_{CLK}$ (default)	PWM_FREQ=%10 $f_{PWM}=2/512 f_{CLK}$	PWM_FREQ=%11 $f_{PWM}=2/410 f_{CLK}$
12MHz (typ. value)	23.4kHz	35.1kHz	46.9kHz	58.5kHz

Table 6.1 Choice of PWM frequency – green / light green: recommended

6.1 Load Indicator Flags

lia and *lib* indicate, if the original duty cycle is driven, or if current regulation limits the PWM duty cycle. When read back as active, the original duty cycle is driven. A cleared flag results from current limiting, e.g. when the motor is blocked, highly loaded, or still accelerating.

6.2 Freewheeling and Passive Braking

The chopper unit provides different options for motor standstill. These options can be enabled by setting *CURRENT_LIMIT.motorryn* to zero, and choosing the desired option using via *FREEWHEEL* setting. The PWM and current regulator become disabled in freewheeling and coil short modes. This way, either freewheeling, or passive braking can be realized. Passive braking is an effective eddy current motor braking, which consumes a minimum of energy, because no active current is driven into the coils.

PARAMETERS RELATED TO CHOPPER			
Parameter	Description	Setting	Comment
<i>PWM_FREQ</i>	PWM frequency selection. Use the lowest setting giving good results. The frequency measured at each of the chopper outputs is half of the effective chopper frequency f_{PWM} .	0	$f_{PWM}=2/1024 f_{CLK}$
		1	$f_{PWM}=2/683 f_{CLK}$
		2	$f_{PWM}=2/512 f_{CLK}$
		3	$f_{PWM}=2/410 f_{CLK}$
<i>FREEWHEEL</i>	Stand still option for both motors, when <i>motorryn</i> flag is cleared (<i>motorryn</i> =0). The freewheeling option makes the motor easy movable, while coil short options realize a passive braking.	0	Normal operation
		1	Freewheeling
		2	Coil short via LS drivers
		3	Coil short via HS drivers
<i>enabledrv</i>	General enable for the motor driver	0	Driver off, all outputs hi-Z
		1	Driver enabled
<i>TBL</i>	Comparator <i>blank time</i> . This time needs to safely cover the switching event and the duration of the ringing on the sense resistor. Choose a setting of 1 or 2 for typical applications. For higher capacitive loads, 3 may be required.	0	16 t_{CLK}
		1	24 t_{CLK}
		2	32 t_{CLK}
		3	40 t_{CLK}

7 Selecting Sense Resistors

Set the desired maximum motor current by selecting an appropriate value for the sense resistor. The following table shows the RMS current values which can be reached using standard resistors and motor types fitting without additional motor current scaling. Additional 15mΩ PCB resistance are included in the calculation.

CHOICE OF R_{SENSE} AND RESULTING MAX. MOTOR CURRENT	
R_{SENSE} [Ω]	current limit [A] <i>IRUN=31</i>
1.50	0.21
1.20	0.26
1.00	0.31
0.82	0.38
0.75	0.41
0.68	0.45
0.50	0.60
470m	0.63
390m	0.75
330m	0.87
270m	1.03
220m	1.23
180m	1.44
150m	1.67
120m	1.97
100m	2.24 (single motor, parallel operation)
82m	2.56 (single motor, parallel operation)

*) At high currents, duty cycle restriction for motion might apply, due to heat up of IC and board.

Sense resistors should be carefully selected. The full motor current flows through the sense resistors. Due to chopper operation the sense resistors see pulsed current from the MOSFET bridges. Therefore, a low-inductance type such as film or composition resistors is required to prevent voltage spikes causing ringing on the sense voltage inputs leading to unstable measurement results. Also, a low-inductance, low-resistance PCB layout is essential. Any common GND path for the two sense resistors must be avoided, because this would lead to coupling between the two current sense signals. A massive ground plane is best. Please also refer to layout considerations in chapter 14.

The sense resistor needs to be able to conduct the peak motor coil current in motor standstill conditions, unless standby power is reduced. Under normal conditions, the sense resistor conducts less than the coil RMS current, because no current flows through the sense resistor during the slow decay phases of the chopper. A 0.25W type is sufficient for most applications up to 800mA RMS.

Attention

Be sure to use a symmetrical sense resistor layout and short and straight sense resistor traces of identical length. Well matching sense resistors ensure best performance.

A compact layout with massive ground plane is best to avoid parasitic resistance effects.

7.1 Motor Torque Limit

Select the sense resistors to deliver enough current for the motor at full current scale. This is the default current scaling ($IRUN = 31$).

$IRUN$ allows for scaling of the limit from $1/32$ to $32/32$:

MOTOR CURRENT CALCULATION WITH UART CONTROL OPTION:

$$I_{MAX} = \frac{IRUN + 1}{32} * \frac{V_{FS}}{R_{SENSE} + 30m\Omega}$$

V_{FS} is the full-scale voltage (please refer to electrical characteristics, V_{SRT}). Typical value is 325mV.

PARAMETERS FOR MOTOR CURRENT CONTROL			
Parameter	Description	Setting	Comment
$IRUN$	Current limit scale when motor is running.	0 ... 31	scaling factor 1/32, 2/32, ... 32/32

8 Driver Diagnostic Flags

The TMC7300 drivers supply a complete set of diagnostic and protection capabilities, like short to GND protection, short to VS protection and undervoltage detection. A detection of current limit condition allows testing if a motor coil connection is interrupted. See the *DRV_STATUS* table for details.

8.1 Temperature Measurement

The driver integrates a two-level temperature sensor (pre-warning and thermal shutdown) for diagnostics and for protection of the IC against excess heat. Heat is mainly generated by the motor driver stages. Most critical situations, where the driver MOSFETs could be overheated, are avoided by the short to GND protection. For many applications, the overtemperature pre-warning will indicate an abnormal operation situation and can be used to initiate user warning or power reduction measures like motor current reduction. The thermal shutdown is just an emergency measure and temperature rising to the shutdown level should be prevented by design.

TEMPERATURE THRESHOLDS	
Temperature Level	Comment
150°C	This value is relatively safe to switch off the driver stage before the IC can be destroyed by overheating. On a large PCB, the power MOSFETs reach roughly 150°C peak temperature when the temperature detector is triggered with this setting.
120°C	Temperature level for pre-warning. In most applications, reaching this level is a sign for abnormal heat accumulation. The overtemperature pre-warning threshold of 120°C gives lots of headroom to react to high driver temperature, e.g. by reducing motor current, or increasing waiting-time in between of two motions.

Attention

Overtemperature protection cannot in all cases avoid thermal destruction of the IC. In case the rated output current is exceeded, excess heat generation can quickly heat up the driver before the overtemperature sensor can react. This is due to a delay in heat conduction over the IC die.

After triggering the overtemperature sensor (*ot* flag), the driver remains switched off until the system temperature falls below the pre-warning level (*otpw*) to avoid continuous heating to the shutdown level.

8.2 Short Protection

The TMC7300 power stages are protected against a short circuit condition by an additional measurement of the current flowing through each of the power stage MOSFETs. This is important, as most short circuit conditions result from a motor cable insulation defect, e.g. when touching the conducting parts connected to the system ground. The short detection is protected against spurious triggering, e.g. by ESD discharges, by retrying three times before switching off the motor.

Once a short condition is safely detected, both driver bridges become switched off, and the *s2ga* or *s2gb* flag, respectively *s2vsa* or *s2vsb* becomes set. In order to restart the motor, disable and re-enable the driver. Note, that short protection cannot protect the system and the power stages for all possible short events, as a short event is rather undefined and a complex network of external components may be involved. Therefore, short circuits should basically be avoided.

8.3 Diagnostic Output

The diagnostic output DIAG provides error status information, especially when using the driver in stand-alone mode. An active DIAG output shows that the driver cannot work normally. Figure 8.1 shows the signals controlling the output.

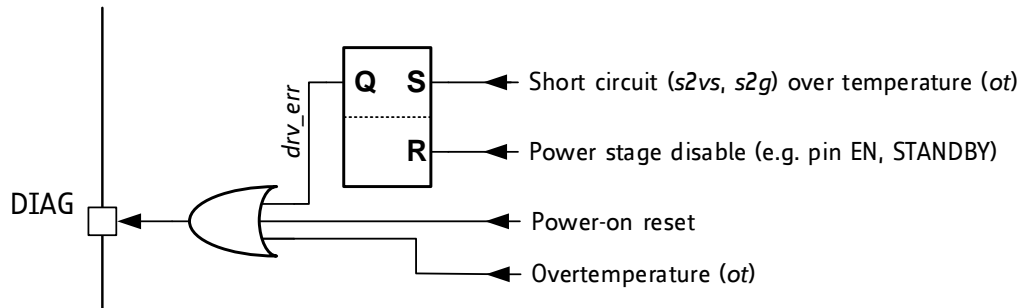

Figure 8.1 DIAG output



9 Quick Configuration Guide

This guide is meant as a practical tool to come to a first configuration. Do a minimum set of measurements and decisions for tuning the driver to fit the application.

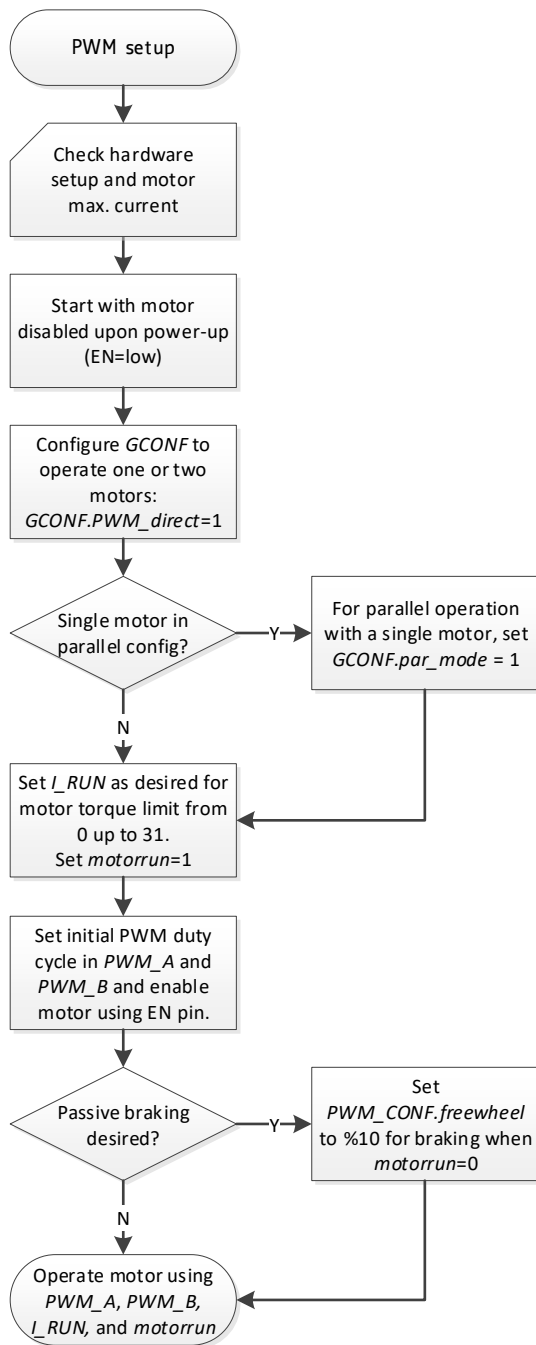

Figure 9.1 Configuration and Motor operation

Hint

Use the evaluation board to explore settings and to generate the required configuration datagrams.

10 External Reset

The chip is loaded with default values during power on via its internal power-on reset. In order to reset the chip to power on defaults, any of the supply voltages monitored by internal reset circuitry (VS or VCC_IO) must be cycled. It is easiest and safest to cycle VCC_IO in order to completely reset the chip. Also, current consumed from VCC_IO is low and therefore it has simple driving requirements. Due to the input protection diodes not allowing the digital inputs to rise above VCC_IO level, all inputs must be driven low during this reset operation. When this is not possible, an input protection resistor may be used to limit current flowing into the related inputs.

11 Clock Oscillator

The clock is the timing reference for all functions: the chopper frequency, the blank time, the standstill power down timing, and the internal step pulse generator etc. The on-chip clock oscillator is not calibrated, but relatively temperature-stable. The internal clock frequency is roughly 12MHz. When the internal pulse generator is used, and increased precision is desired, measure the internal frequency by doing a test-motion (with motor disabled) and adapt the pulse frequency to the actual value of the frequency. Store the calibration value into the microcontroller's EEPROM for the application.

12 Absolute Maximum Ratings

The maximum ratings may not be exceeded under any circumstances. Operating the circuit at or near more than one maximum rating at a time for extended periods shall be avoided by application design.

Parameter	Symbol	Min	Max	Unit
Supply voltage operating with inductive load *)	V_{VS}	-0.5	11.2	V
Supply and bridge voltage max. *)	V_{VMAX}		13	V
I/O supply voltage	V_{VIO}	-0.5	5.5	V
digital supply voltage	V_{1V8OUT}	-0.5	1.95	V
Logic input voltage	V_I	-0.5	$V_{VIO}+0.5$	V
MODE input voltage (Do not exceed both, VCC_IO and 5VOUT by more than 10%, as this enables a test mode)	V_{VREF}	-0.5	6	V
Maximum current to / from digital pins and analog low voltage I/Os	I_{IO}		+/-10	mA
1.8V regulator output current (internal plus external load)	I_{5VOUT}		20	mA
Maximum mean or DC current per bridge MOS at $T_J < 110^\circ\text{C}$	I_{OxDC}		1.0	A
Power bridge repetitive output current	I_{Ox}		2.0	A
Maximum VS current (both bridges operating)	I_{VS}		2.8	A
Maximum BRx current	I_{Ox}		2.0	A
Junction temperature	T_J	-50	150	$^\circ\text{C}$
Storage temperature	T_{STG}	-55	150	$^\circ\text{C}$
ESD-Protection for handling (Human body model, HBM)	V_{ESD}		1.5	kV

*) Stray inductivity of GND and VS connections will lead to ringing of the supply voltage when driving an inductive load. This ringing results from the fast switching slopes of the driver outputs in combination with reverse recovery of the body diodes of the output driver MOSFETs. Even small trace inductivities as well as stray inductivity of sense resistors can easily generate a few volts of ringing leading to temporary voltage overshoot. This should be considered when working near the maximum voltage.

13 Electrical Characteristics

13.1 Operational Range

Parameter	Symbol	Conditions	Min	Max	Unit
Junction temperature	T_J		-40	125	$^\circ\text{C}$
Supply voltage	V_{VS}		2	11	V
Supply & IO voltage battery empty limit	V_{VS}		1.8		V
I/O supply voltage	V_{VIO}		2	5.25	V
Mean current per full bridge output for continuous operation (value for design guideline)	I_{RMS}	$V_{VS} < 2.1\text{V}$		0.6	A
		$V_{VS} \geq 2.1\text{V}$		0.8	
		$V_{VS} \geq 2.2\text{V}$		1.0	
RMS motor current per fullbridge, duty cycle limited operation	I_{RMS}	$V_{VS} \geq 2.5\text{V}$ $T_J < 110^\circ\text{C}$		1.2	A
Peak output current per fullbridge output	I_{Ox}	$T_J < 110^\circ\text{C}$		1.7	A
Sum of output current (VS supply pin current)	I_{VS}			2.4	A

13.2 DC and Timing Characteristics

DC characteristics contain the spread of values guaranteed within the specified supply voltage range unless otherwise specified. Typical values represent the average value of all parts measured at +25°C. Temperature variation also causes stray to some values. A device with typical values will not leave Min/Max range within the full temperature range.

Power supply current		DC-Characteristics				
		$V_{VS} = 8.0V, V_{VIO}=3.3V$				
Parameter	Symbol	Conditions	Min	Typ	Max	Unit
Total supply current, driver disabled	I_{VS}	disable via UART		4	8	mA
		disable via EN=0		1.5	3	mA
Total supply current, operating, I_{VS}	I_{VS}	default chopper, no load		7	12	mA
IO supply current operating	I_{VIO}	no load on outputs, inputs at V_{IO} or GND		60	200	μA
Total supply current, low-power standby, I_{VS}	I_{VS}	$V_{VIO} < 0.2V$		0.03	1	μA

Motor driver section		DC- and Timing-Characteristics				
		$V_{VS} = 8.0V, V_{VIO}=3.3V$				
Parameter	Symbol	Conditions	Min	Typ	Max	Unit
RDS _{ON} lowside MOSFET	R_{ONL}	measure at 100mA, 25°C, $V_{VS} \geq 3.2V$		0.17	0.25	Ω
RDS _{ON} highside MOSFET	R_{ONH}	measure at 100mA, 25°C, $V_{VS} \geq 3.2V$		0.17	0.25	Ω
slope, rising	$t_{SLPRISE}$	value for reference		20		ns
slope, falling	$t_{SLPFALL}$	value for reference		7		ns
Current sourcing, driver off	I_{OIDLE}	O_{XX} pulled to GND	6	13	30	μA
Recommended / max. VS power-up slope to >5V	VS_{RAMP}	Hint: Normally satisfied due to ext. capacitor on VS.		<0.33 rcd.	1	V/ μS

Charge pump		DC-Characteristics				
Parameter	Symbol	Conditions	Min	Typ	Max	Unit
Charge pump output voltage (mean)	$V_{VCP-VVS}$	$V_{VS} \geq 3.5V$	4.2	5.1	5.7	V

Linear regulator		DC-Characteristics				
		$V_{VS} = 8.0V, V_{VIO}=3.3V$				
Parameter	Symbol	Conditions	Min	Typ	Max	Unit
Output voltage	V_{SVOUT}	$I_{1V8OUT} = 0mA$ $T_J = 25^\circ C$	1.65	1.8	1.95	V

Clock oscillator and input		Timing-Characteristics				
Parameter	Symbol	Conditions	Min	Typ	Max	Unit
Clock oscillator frequency	f_{CLKOSC}	$t_J = -50^\circ C$		11.7		MHz
	f_{CLKOSC}	$t_J = 25^\circ C$	9	12.0	15	MHz
	f_{CLKOSC}	$t_J = 150^\circ C$		12.1		MHz

Detector levels		DC-Characteristics				
		$V_{VS} = 8.0V, V_{VIO}=3.3V$				
Parameter	Symbol	Conditions	Min	Typ	Max	Unit
V_{VS} undervoltage threshold for RESET	V_{UV_VS}	V_{VS} rising		1.8	2.1	V
		V_{VS} falling	1.5	1.7	1.85	V
V_{VIO} undervoltage threshold for RESET	V_{UV_VIO}	V_{VIO} rising		1.8	1.9	V
		V_{VIO} falling	1.5	1.7		
V_{VIO} low power standby input voltage	$V_{UV_VIOHYST}$				0.4	V
Worst case power-up delay time		$V_{VS} = 2.0V, V_{VIO}=2.0V$			500	μs
Short to GND detector threshold ($V_{VS} - V_{Ox}$)	V_{OS2G}	$V_{VS} \geq 3.5V$ required for operation	0.5	0.8		V
Short to VS detector threshold (V_{Ox})	V_{OS2G}		1.0	1.2	1.6	V
Short detector delay (high side / low side switch on to short detected)	t_{S2G}			1		μs
Overtemperature prewarning 120°C	t_{OTPW}	Temperature rising	100	120	140	°C
Overtemperature shutdown 150°C	t_{OT150}	Temperature rising	135	150	170	°C
3.5V Detector Threshold $U3V5$	V_{VS3V5}	VS falling	3.15	3.5		V
3.5V Detector Threshold $U3V5$	V_{VS3V5}	VS rising		3.7	4.1	V
COMP1A2, COMP1B2 Offset Voltage	V_{CABOFS}	Lowside MOSFETs ON			+10	mV

Sense resistor voltage levels		DC-Characteristics				
		$f_{CLK}=16MHz$				
Parameter	Symbol	Conditions	Min	Typ	Max	Unit
Sense input peak threshold voltage (low sensitivity)	V_{SRT}	$cs_{actual}=31$ $CUR_A/B=248$ $Hyst.=0; I_{BRxy}=0$		325		mV
Sense input tolerance / motor current full scale tolerance	I_{COIL}		-5		+5	%
Internal resistance from pin BRxy to internal sense comparator (additional to sense resistor)	R_{BRxy}			30		m Ω

Digital pins		DC-Characteristics				
Parameter	Symbol	Conditions	Min	Typ	Max	Unit
Input voltage low level	V_{INLO}		-0.3		$0.3 V_{VIO}$	V
Input voltage high level	V_{INHI}		$0.7 V_{VIO}$		$V_{VIO}+0.3$	V
Input Schmitt trigger hysteresis	V_{INHYST}	$V_{VIO}=3.3V$		$0.12 V_{VIO}$		V
Output voltage low level	V_{OUTLO}	$I_{OUTLO} = 2mA,$ $V_{VIO}=3.3V$			0.2	V
Output voltage high level	V_{OUTHY}	$I_{OUTHY} = -2mA,$ $V_{VIO}=3.3V$	$V_{VIO}-0.2$			V
Input leakage current	I_{ILEAK}		-1		1	μA
Digital pin capacitance	C			3.5		pF

13.3 Thermal Characteristics

The following table shall give an idea on the thermal resistance of the package. The thermal resistance for a four-layer board will provide a good idea on a typical application. Actual thermal characteristics will depend on the PCB layout, PCB type and PCB size. The thermal resistance will benefit from thicker CU (inner) layers for spreading heat horizontally within the PCB. Also, air flow will reduce thermal resistance.

A thermal resistance of 40K/W for a typical board means, that the package is capable of continuously dissipating 1W at an ambient temperature of 85°C with the die temperature staying below/at 125°C. Note, that a thermally optimized layout is required.

Parameter	Symbol	Conditions	Typ	Unit
Typical power dissipation	P_D	1A RMS in two motors (or single motor with 2A RMS in parallel circuit), 35kHz chopper, 11V, 60°C peak surface of package	1	W
Typical power dissipation	P_D	0.7A RMS in two motors (or single motor with 1.4A RMS in parallel circuit), sinewave, 35kHz chopper, 11V, 45°C peak surface of package	0.5	W
Thermal resistance junction to ambient on a multilayer board	R_{TMJA}	Dual signal and two internal power plane board (2s2p) as defined in JEDEC EIA JESD51-5 and JESD51-7 (FR4, 35µm CU, 70mm x 133mm, d=1.5mm)	40	K/W
Thermal resistance junction to case	R_{TJC}	Junction to heat slug of package	7	K/W

Table 13.1 Thermal characteristics

Note

A spread-sheet for calculating power dissipation is available on www.trinamic.com.

14 Layout Considerations

14.1 Exposed Die Pad

The TMC7300 uses its die attach pad to dissipate heat from the drivers and the linear regulator to the board. For best electrical and thermal performance, use a reasonable amount of solid, thermally conducting vias between the die attach pad and the ground plane. The printed circuit board should have a solid ground plane spreading heat into the board and providing for a stable GND reference.

14.2 Wiring GND

All signals of the TMC7300 are referenced to their respective GND. Directly connect all GND pins under the device to a common ground area (GND and die attach pad). The GND plane right below the die attach pad should be treated as a virtual star point. For thermal reasons, the PCB top layer shall be connected to a large PCB GND plane spreading heat within the PCB.

Attention

Especially the sense resistors are susceptible to GND differences and GND ripple voltage. No current other than the sense resistor current should flow on their connections to GND and to the TMC7300. Optimally place them close to the IC, with one or more vias to the GND plane for each sense resistor. The two sense resistors should not share a common ground connection trace or vias, as also PCB traces have a certain resistance.

14.3 Supply Filtering

The 1.8VOUT output voltage ceramic filtering capacitor (100nF recommended) should be placed as close as possible to the 1.8VOUT pin, with its GND return going directly to the die pad or the nearest GND pin. This ground connection shall not be shared with other loads or additional vias to the GND plane. Use as short and as thick connections as possible.

The motor supply pins VS should be decoupled with a ceramic, or a ceramic plus an electrolytic capacitor (47 μ F or larger is recommended, depending on the motor coil current). Place the capacitors close to the device.

Take into account that the switching motor coil outputs have a high dV/dt. Thus, capacitive stray into high resistive signals can occur, if the motor traces are near other traces over longer distances.

14.4 Layout Example

Schematic

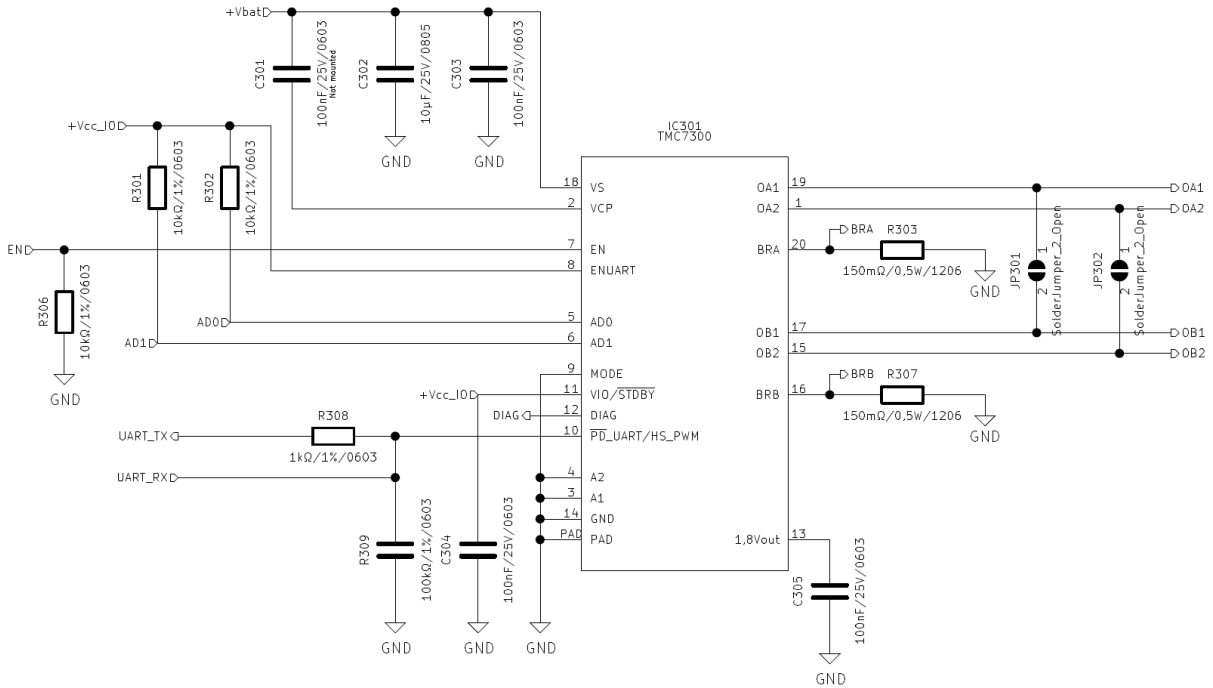

Placement (Excerpt)

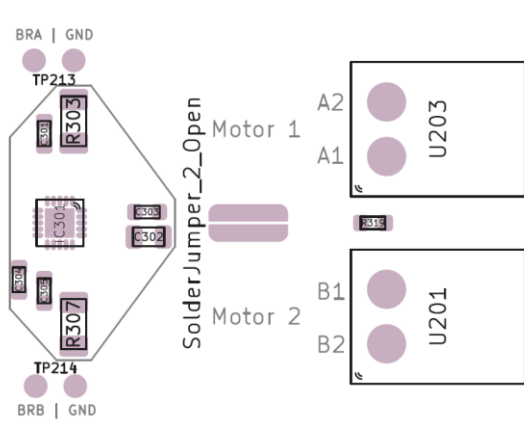

Top Layout (Excerpt, showing die pad vias)

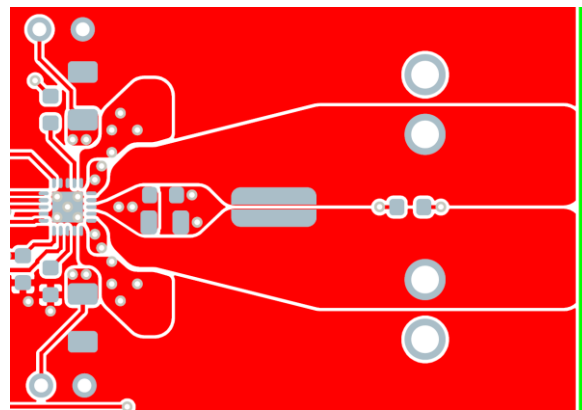

The complete schematics and layout data for all evaluation boards are available on the TRINAMIC website.

15 Package Mechanical Data

15.1 Dimensional Drawings QFN20

Attention: Drawings not to scale.

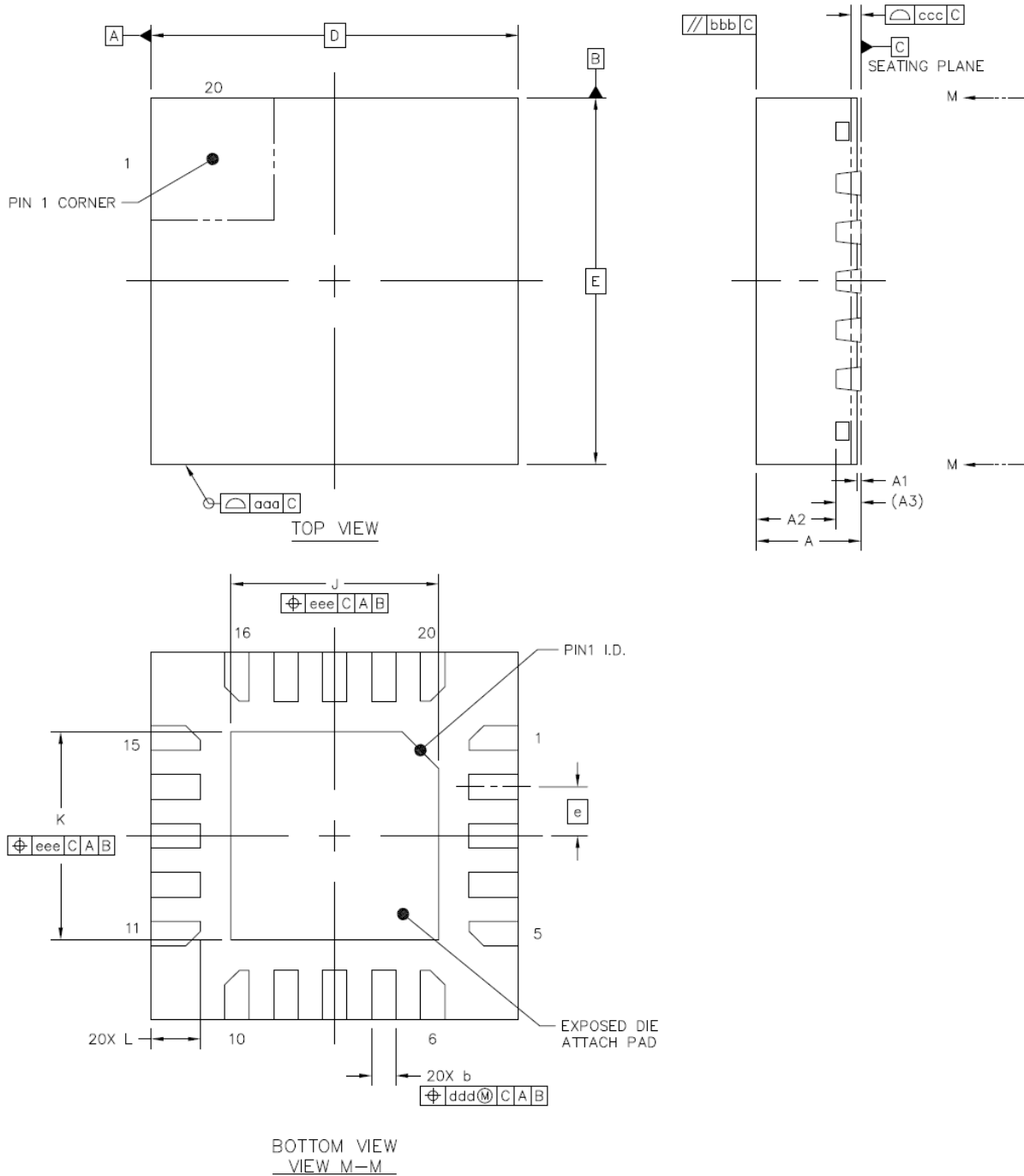

Figure 15.1 Dimensional drawings QFN20

Parameter	[mm]	Ref	Min	Nom	Max
total thickness		A	0.8	0.85	0.9
stand off		A1	0	0.035	0.05
mold thickness		A2		0.65	0.67
lead frame thickness		A3		0.203	
Lead width		b	0.15	0.2	0.25
body size X		D		3.0	
body size Y		E		3.0	
lead pitch		e		0.4	
exposed die pad size X		J	1.6	1.7	1.8
exposed die pad size Y		K	1.6	1.7	1.8
lead length		L	0.35	0.4	0.45
package edge tolerance		aaa			0.1
mold flatness		bbb			0.1
coplanarity		ccc			0.08
lead offset		ddd			0.1
exposed pad offset		eee			0.1

15.2 Package Codes

Type	Package	Temperature range	Code & marking
TMC7300-LA	QFN20 (RoHS)	-40°C ... +125°C	(TMC logo) 7300

16 Designed for Sustainability

Sustainable growth is one of the most important and urgent challenges today. We at Trinamic try to contribute by designing highly efficient IC products, to minimize energy consumption, ensure best customer experience and long-term satisfaction by smooth and silent run, while minimizing the demand for external resources, e.g. for power supply, cooling infrastructure, reduced motor size and magnet material by intelligent control interfaces and advanced algorithms.

Please help and design efficient and durable products made for a sustainable world.

17 Table of Figures

FIGURE 1.1 TMC7300 BASIC APPLICATION BLOCK DIAGRAM FOR TWO DC MOTORS.....	4
FIGURE 1.2 UART CONTROLLED SINGLE OR DUAL DC MOTOR DRIVER.....	5
FIGURE 1.3 PERIPHERAL POWER DRIVER	5
FIGURE 2.1 TMC7300 PINNING TOP VIEW STEPPER DRIVER – QFN20, 3X3MM ² , 0.4MM PITCH.....	7
FIGURE 2.2 TMC7300 PINNING TOP VIEW STEPPER DRIVER – QFN20, 3X3MM ² , 0.4MM PITCH.....	8
FIGURE 3.1 OPERATION OF TWO DC-MOTORS FOR 1.8V TO 11V SUPPLY.....	10
FIGURE 3.2 OPERATION OF A SINGLE DC-MOTOR (DOUBLE CURRENT)	11
FIGURE 3.3 HALFBRIDGE DRIVER MODE	12
FIGURE 3.4 R _{DS(on)} VARIATION OVER SUPPLY VOLTAGE.....	13
FIGURE 3.5 SWITCHING TO STANDBY AND BACK ON.....	14
FIGURE 3.6 ADDITIONAL CIRCUIT FOR I/O VOLTAGE <1.80V.....	14
FIGURE 4.1 ATTACHING THE TMC7300 TO A MICROCONTROLLER UART	17
FIGURE 4.2 ADDRESSING MULTIPLE TMC7300 VIA SINGLE WIRE INTERFACE USING ANALOG SWITCHES	18
FIGURE 8.1 DIAG OUTPUT.....	31
FIGURE 9.1 CONFIGURATION AND MOTOR OPERATION.....	32
FIGURE 15.1 DIMENSIONAL DRAWINGS QFN20.....	40

18 Revision History

Version	Date	Author BD= Bernhard Dwersteg	Description
V0.9	2019-Jun-24	BD	Edited electrical data based on prototype measurements, first version of datasheet
V0.91	2019-Jul-18	BD	Added RDSon measurement of power stage
V1.00	2019-Aug-02	BD	Minor changes
V1.01	2019-Nov-06	BD	Minor wording, added chapter on sustainability, added chapter on low I/O voltage operation
V1.02	2019-Nov-10	BD	Minor wording <i>IRUN</i> limit
V1.03	2020-May-19	BD	Updated Logo
V1.04	2020-Jun-02	BD	Complemented operational range

Table 18.1 Document Revisions

19 References

[TMC7300-EVAL] TMC7300 Evaluation board: Manuals, software and PCB data available on www.trinamic.com