

TMCM-1110 Hardware Manual

Hardware Version V2.30 | Document Revision V1.12 • 2019-APR-03

The TMCM-1110_V23 stepRocker is a single axis motor controller/driver board for 2-phase bipolar stepper motors. It features the TRINAMIC controller/driver chain consisting of TMC429 and TMC262 in combination with an ARM Cortex-M4™ (MK20DX128VLK7) processor. The Module is intended to be a fully functional development platform. A stepRocker can be extended to a full 3-axes system using two additional boards, because the TMCM-1110 stepRocker board can be both, master or slave.

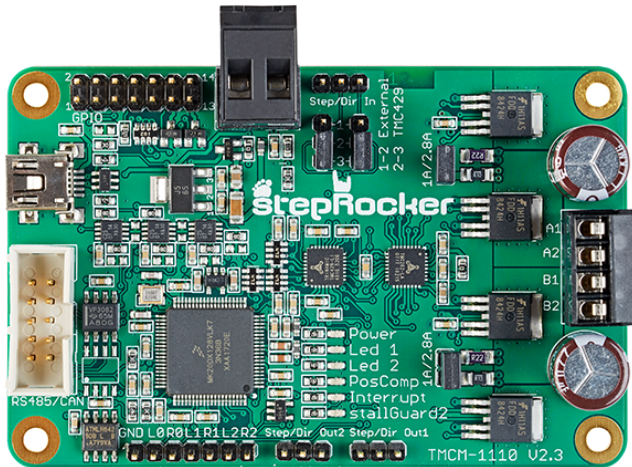

Features

- Single axis controller/driver for 2-phase bipolar stepper motor
- 2 and 3 axes systems are possible with additional boards configured as slaves
- +10...30V DC supply voltage
- Up to 2.8A RMS motor current
- RS485 & USB interface
- Multi-purpose inputs and outputs

Applications

- Laboratory Automation
- Manufacturing
- Robotics
- Factory Automation
- Test & Measurement
- Technology evaluation
- First experiences with stepper motors
- Hobby applications

Simplified Block Diagram

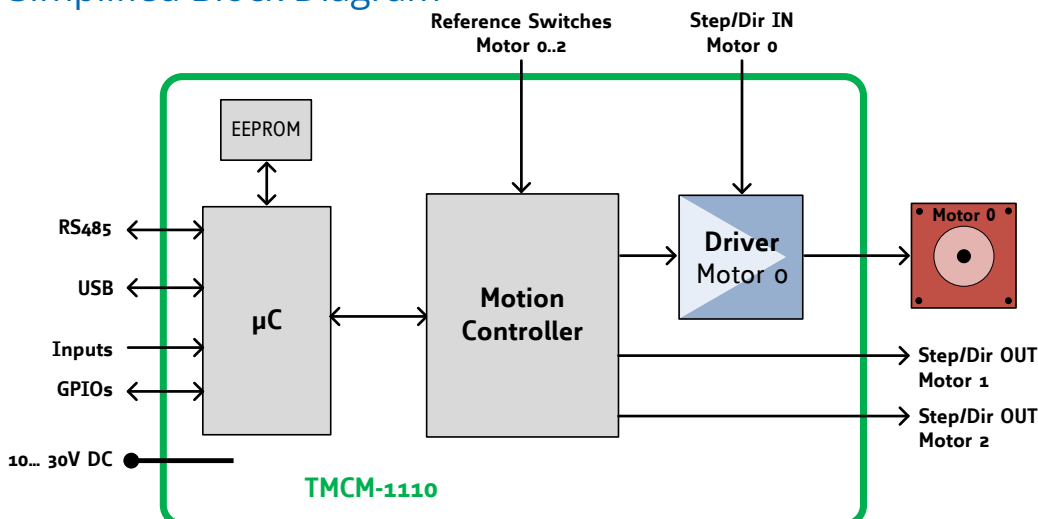

Contents

1	Features	3
2	Order Codes	4
3	Mechanical and Electrical Interfacing	5
3.1	Size of board	5
4	Connectors	6
4.1	Power Connector	7
4.2	I/O Connector (Microcontroller)	7
4.3	Motor Connector	8
4.4	Reference Switch Connector (TMC429)	9
4.5	RS485 and CAN Connector	9
4.5.1	Upgrade the stepRocker for CAN communication	10
4.6	USB Connector	10
4.7	Step/Dir Input Connector (Motor 0)	10
4.8	Step/Dir Output Connectors (Motor 1 and Motor 2)	11
4.9	Microcontroller Programming Interface	11
5	Jumper Settings	13
6	LEDs	14
7	Communication	15
7.1	RS485	15
7.2	USB	16
7.3	CAN (Retro-fit Option)	16
8	Functional Description	18
8.1	Extensions of the TMC-1110 stepRocker	19
9	Operational Ratings and Characteristics	20
10	Abbreviations used in this Manual	21
11	Figures Index	22
12	Tables Index	23
13	Supplemental Directives	24
13.1	Producer Information	24
13.2	Copyright	24
13.3	Trademark Designations and Symbols	24
13.4	Target User	24
13.5	Disclaimer: Life Support Systems	24
13.6	Disclaimer: Intended Use	24
13.7	Collateral Documents & Tools	25
14	Revision History	26
14.1	Hardware Revision	26
14.2	Document Revision	26



1 Features

The TMCM-1110_V23 stepRocker is a single axis motor controller/driver board for 2-phase bipolar stepper motors. It features the TRINAMIC controller/driver chain consisting of TMC429 and TMC262 in combination with an ARM Cortex-M4™ (MK20DX128VLK7) processor. The Module is intended to be a fully functional development platform. A stepRocker can be extended to a full 3-axes system using two additional boards, because the TMCM-1110 stepRocker board can be both, master or slave.

Applications

- Highly compact single axis stepper motor controller/driver board for 2-phase bipolar stepper motors
- 2- and 3-axis systems using additional boards as slaves

Electrical data

- Supply voltage: +24V DC (+10... +30V DC)
- Motor current: up to 1A RMS or 2.8A RMS (can be selected with jumpers)

Mechanical data

- Board size: 85mm x 55mm, height 15mm max. without mating connectors
- 4 mounting holes for M3 screws

Interfaces

- RS485 host interface
- USB 2.0 host interface (mini-USB connector)
- Step/Dir input (TTL level)
- Step/Dir outputs (TTL level) for multi axis applications
- 3 multi-purpose inputs (can be used for ABN-encoder)
- 2 limit switch inputs per motor
- 6 multi-purpose I/Os
- 2 open-drain outputs
- μ C programming interface SWD (single wire debug / pads on PCB)
- Retro-fit option: CAN 2.0B communication interface

Features

- TMC429 stepper motor controller IC for on-the-fly alteration of many motion specific parameters
- TMC262 advanced stepper motor driver IC with StallGuard2™ and CoolStep™ features. Using the SpreadCycle chopper the μ step current sine wave is well formed with smooth zero crossing.
- Up to 256 microsteps per fullstep through MicroPlyer technology
- 2 x end switch for all three axes.
- EEPROM

Software

- TMCL™ remote (direct mode) and standalone operation (memory for up to 1024 TMCL™ commands)
- Fully supported by TMCL-IDE (PC based integrated development environment)



2 Order Codes

The standard version of the stepRocker has RS485 and USB interfaces (CAN transceiver **not** assembled). The module is pre-programmed with TRINAMICs TMCL™ firmware with all available features.

TMCM-1110_V23 Order Code		
Order Code	Description	Size (LxWxH)
TMCM-1110_V23 stepRocker	The stepRocker is a 1-axis bipolar stepper motor controller/driver module with RS485 and USB	85mm x 55mm x 15mm

Table 1: TMCM-1110_V23 Order Code



3 Mechanical and Electrical Interfacing

3.1 Size of board

The board with the controller/driver electronics has an overall size of 85mm x 55mm x 15mm without mating connectors. It offers four mounting holes for M3 screws (3.2mm diameter). All four mounting holes are connected to the ground plane (signal and supply ground) of the module.

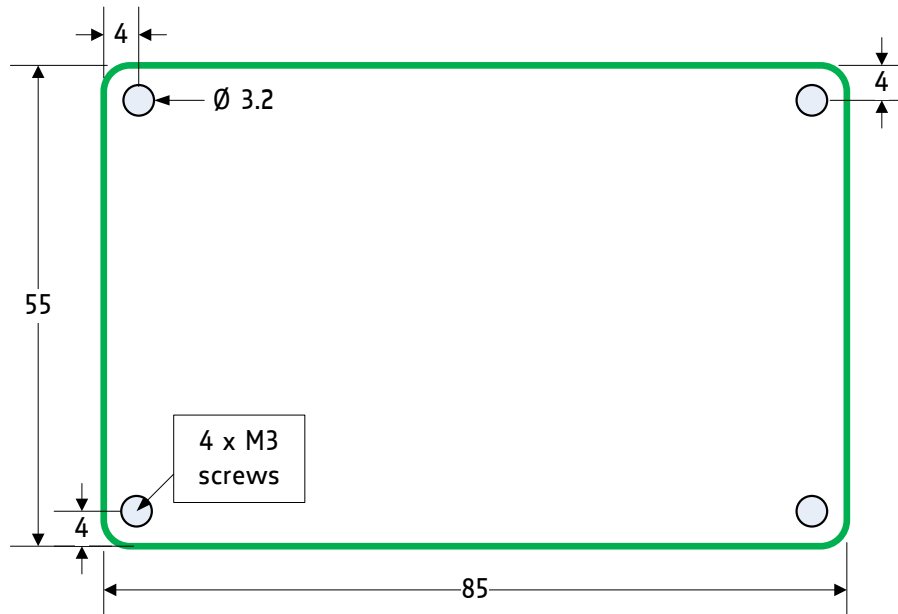

Figure 1: Board Dimensions and Positions of Mounting Holes (all Values in mm)



4 Connectors

The TMCM-1110_V23 stepRocker has nine connectors altogether. There are two screw connectors for power and motor and two interface connectors (mini-USB and RS485). Furthermore, the stepRocker has one connector for reference switches for all three motors, the driver input connector (TTL level) for motor 0, two controller output connectors (TTL level) for motors 1 and 2 and the GPIO connector, which can be used e.g. for connecting an ABN-encoder.

NOTICE Start with power supply OFF and do not connect or disconnect motor during operation! Motor cable and motor inductivity might lead to voltage spikes when the motor is (dis)connected while energized. These voltage spikes might exceed voltage limits of the driver MOSFETs and might permanently damage them. Therefore, always switch off / disconnect power supply or at least disable driver stage before connecting / disconnecting motor.

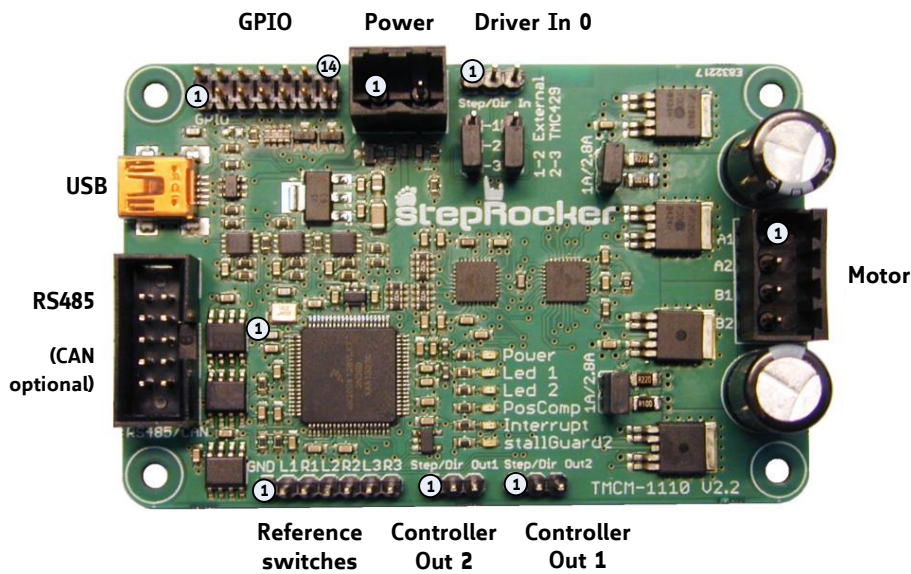

Figure 2: TMCM-1110 stepRocker Connectors

Connector Types and Mating Connectors		
Connector	Connector type on-board	Mating connector type
Power	RIA 220-02, 2 pin, 5.08mm pitch, shrouded header	RIA 249-02, screw type terminal block, pluggable, centerline 5.08mm pitch
Motor	RIA 183-04, 4 pin, 3.5mm pitch, schrouded header	RIA 169-04, screw type terminal block, pluggable, centerline 3.5mm pitch
USB	USB-mini female connector	USB-mini male connector
RS485/CAN	Low profile box header without locking bar, type 8380, 10 pin, DIN 41651, 2.54mm pitch	Low profile IDC socket connector, 10 pin, DIN 41651, 2.54mm pitch



Connector	Connector type on-board	Mating connector type
GPIO	Multi-pin-connector, 14 pin, 2.54mm pitch	Female connector with 2.54mm pitch
Ref. switches	Multi-pin-connector, 7pin, 2.54mm pitch	Female connector with 2.54mm pitch
Driver In	Multi-pin-connector, 3 pin, 2.54mm pitch	Female connector with 2.54mm pitch
Controller Out 1, 2	Multi-pin-connector, 3 pin, 2.54mm pitch	Female connector with 2.54mm pitch

Table 2: Connector Types and Mating Connectors of the TMCM-1110 stepRocker

4.1 Power Connector

Power Supply Connector Pin Assignment			
Pin	Label	Direction	Description
1	GND	Power (GND)	Common system supply and signal ground
2	10...30V	Power (input)	Power supply voltage

Table 3: Power Supply Connector Pin Assignment

NOTICE

Do not connect or disconnect motor during operation! Motor cable and motor inductivity might lead to voltage spikes when the motor is (dis)connected while energized. These voltage spikes might exceed voltage limits of the driver MOSFETs and might permanently damage them. Therefore, always switch off / disconnect power supply or at least disable driver stage before connecting / disconnecting motor.

NOTICE

Take care of polarity, wrong polarity can destroy the board!

4.2 I/O Connector (Microcontroller)

The TMCM-1110_V23 offers an on-board ARM Cortex-M4™ microcontroller with +3V3 powered IOs and +5V tolerant inputs. In order to be compatible with previous generations of the module, +5V output level-shifters/buffers have been integrated on-board. This way, all general purpose IO pins configured as outputs will deliver +5V TTL signals.

I/O Connector Pin Assignment			
Pin	Label	Direction	Description
1	GND	Power (GND)	Supply and signal ground
2	GND	Power (GND)	Supply and signal ground
3	PWMD_0	in/out	General purpose I/O (+5V compatible, default: input)



Pin	Label	Direction	Description
4	PWMU_0	in/out	General purpose I/O (+5V compatible, default: output)
5	PWMD_1	in/out	General purpose I/O (+5V compatible, default: input)
6	PWMU_1	in/out	General purpose I/O (+5V compatible, default: output)
7	PWMD_2	in/out	General purpose I/O (+5V compatible, default: input)
8	PWMU_2	in/out	General purpose I/O (+5V compatible, default: output)
9	AIN_0	in	Analog input (can be used as home switch). Input voltage range: 0...+10V Resolution: 12bit (0...4095)
10	PHASE_A	in	Encoder input channel A (+5V compatible, internal pull-up to +5V)
11	OpenDrain_1	out	Open-drain output (max. 100mA)
12	PHASE_B	in	Encoder input channel B (+5V compatible, internal pull-up to +5V)
13	OpenDrain_2	out	Open-drain output (max. 100mA)
14	PHASE_Z	in	Encoder input zero channel (+5V compatible, internal pull-up to +5V)

Table 4: I/O Connector Pin Assignment

4.3 Motor Connector

The motor has to be connected to the motor connector, one phase (phase A) between A1 and A2 and the second phase (phase B) between B1 and B2.

Motor Connector Pin Assignment			
Pin	Label	Direction	Description
1	A1	out	Pin 1 of motor coil A
2	A2	out	Pin 2 of motor coil A
3	B1	out	Pin 1 of motor coil B
4	B2	out	Pin 2 of motor coil B

Table 5: Motor Connector Pin Assignment



NOTICE

Do not connect or disconnect motor during operation! Motor cable and motor inductivity might lead to voltage spikes when the motor is (dis)connected while energized. These voltage spikes might exceed voltage limits of the driver MOSFETs and might permanently damage them. Therefore, always switch off / disconnect power supply or at least disable driver stage before connecting / disconnecting motor.

4.4 Reference Switch Connector (TMC429)

Reference Switch Connector Pin Assignment			
Pin	Label	Direction	Description
1	GND	Power (GND)	Signal and system ground
2	L1	in	Input for left reference/limit switch of motor 0
3	R1	in	Input for right reference/limit switch of motor 0
4	L2	in	Input for left reference/limit switch of motor 1
5	R2	in	Input for right reference/limit switch of motor 1
6	L3	in	Input for left reference/limit switch of motor 2
7	R3	in	Input for right reference/limit switch of motor 2

Table 6: Reference Switch Connector Pin Assignment

4.5 RS485 and CAN Connector

The standard TMC-1110_V23 stepRocker offers the RS485 interface, only.

RS485/CAN Connector Pin Assignment			
Pin	Label	Direction	Description
1			
2			
3	CAN_L	bi-directional	differential CAN bus signal (inverting) - retro-fit option
4	CAN_H	bi-directional	differential CAN bus signal (non-inverting) - retro-fit option
5	GND	Power (GND)	Signal and system ground
6	RS485+	bi-directional	differential RS485 bus signal (non-inverting)
7	RS485-	bi-directional	differential RS485 bus signal (inverting)
8			
9			
10			

Table 7: RS485/CAN Connector Pin Assignment



4.5.1 Upgrade the stepRocker for CAN communication

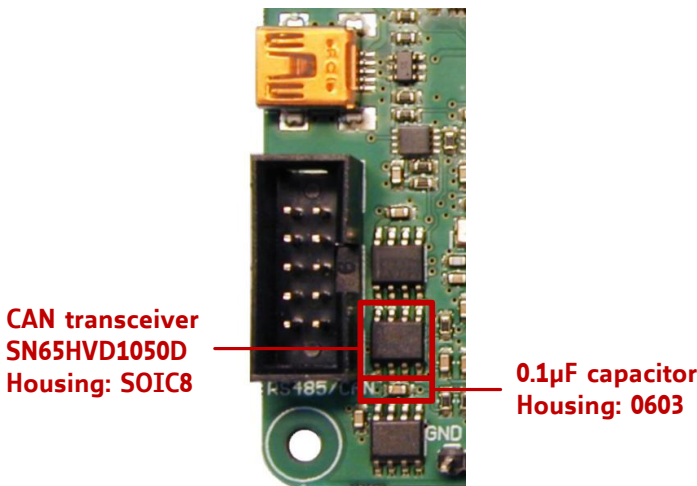

The previous table further above shows the pin configuration for CAN, too. Before starting with CAN it is necessary to solder a SN65HVD1050D CAN transceiver with housing SOIC8 and a 0.1µF capacitor with housing 0603 on the TCM-1110_V23 stepRocker. Afterwards, the stepRocker is ready for using the CAN interface.

Because of the pin assignment CAN and RS485 can be used at the same time.

Please note: it is not necessary to remove the RS485 transceiver.

4.6 USB Connector

A USB interface is available via a mini-USB connector. This module supports USB 2.0 Full-Speed (12Mbit/s) connections.

USB Connector Pin Assignment			
Pin	Label	Direction	Description
1	VBUS	Power (+5V input)	+5V supply from the host
2	D-	bi-directional	USB Data-
3	D+	bi-directional	USB Data+
4	ID		Connected to signal and system ground
5	GND	Power (GND)	Signal and system ground

Table 8: USB Connector Pin Assignment

4.7 Step/Dir Input Connector (Motor 0)

The TCM-1110 stepRocker is equipped with a step/dir input connector for motor 0. Via this connector an external motion controller can be used together with the on-board driver electronics. For selecting an external motion controller instead of the on-board TMC429 motion controller two jumpers have to be set (please refer to chapter 5).

Step/Dir Input Connector Pin Assignment			
Pin	Label	Direction	Description
1	GND	Power (GND)	Signal and System ground
2	Step In	in	Driver step input signal (+5V compatible)
3	Dir In	in	Driver direction input signal (+5V compatible)



Pin	Label	Direction	Description
-----	-------	-----------	-------------

Table 9: Step/Dir Input Connector Pin Assignment

4.8 Step/Dir Output Connectors (Motor 1 and Motor 2)

The TMC429 motion controller on the stepRocker is able to control up to three stepper motors. Its Step/Dir outputs (TTL level) for motor 1 and motor 2 are available via connectors Step/Dir Out 1 and Step/Dir Out 2. The TMC-1110 stepRocker can be extended to a complete motion controller/driver system for all three motors.



Step/Dir Output Connector Pin Assignment			
Pin	Label	Direction	Description
1	GND	Power (GND)	Signal and System ground
2	Step Out	out	Driver step output signal (+5V compatible)
3	Dir Out	out	Driver direction output signal (+5V compatible)

Table 10: Step/Dir Output Connector Pin Assignment

NOTICE

Note For setting the **step pulse length** global parameter **86** is used. Adjust this parameter with the **SGP** command. Refer to the TMCL Firmware Manual of the stepRocker for further information.

4.9 Microcontroller Programming Interface

The programming pads for the microcontroller are located on the bottom side of the module. They are connected directly to the related processor pins - resp. GND or on-board generated +3V3 supply. These pins are used for programming of the bootloader and firmware during production + testing of the module.

Programming Pads		
Pin	Label	Description
1	GND	Module and signal ground
2	+3V3	+3V3 DC supply - generated on-board
3	nRST	Hardware reset input
4	SWDIO	Serial wire data I/O
5	SWDCLK	Serial wire clock

Table 11: Programming Pads on Bottom of the PCB



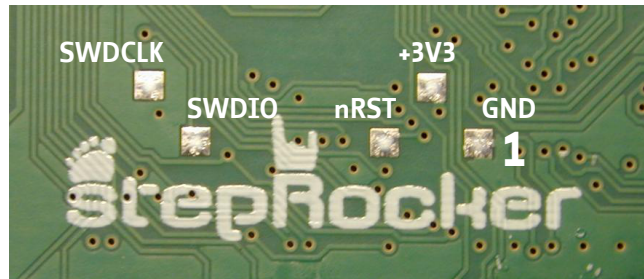

5 Jumper Settings

The TMCM-1110_V23 stepRocker offers a number of jumpers for selection of different settings in hardware.

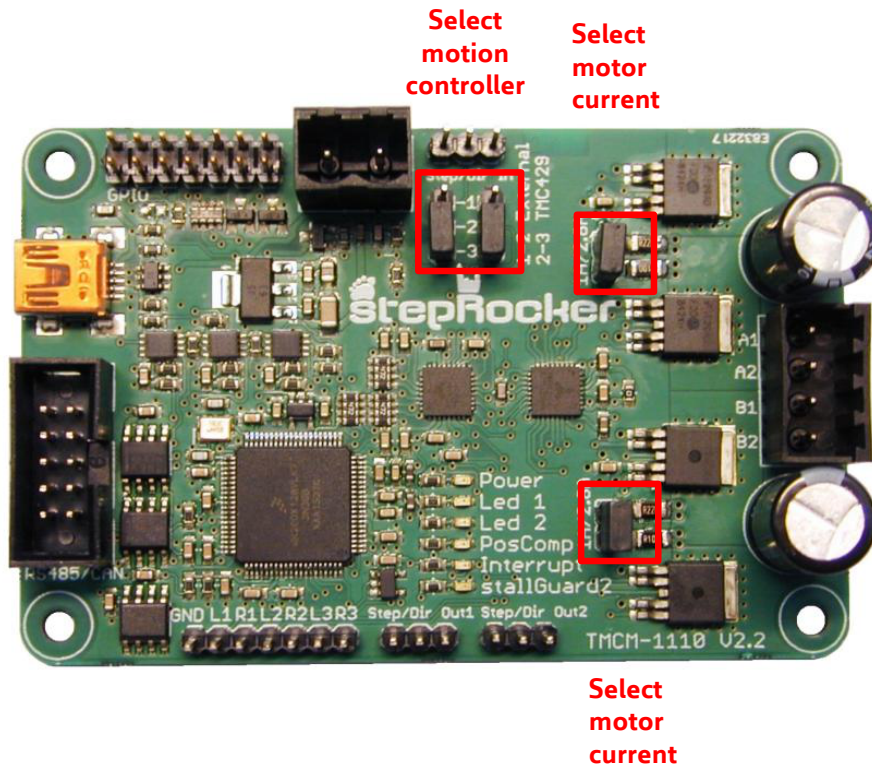

Figure 3: Jumper Settings of the TMCM-1110_V23 stepRocker

Jumpers of the TMCM-1110_V23 stepRocker		
Jumper	Label	Description
Select motor current	1A/2.8A	Jumper plugged: motor current up to 2.8A RMS, Jumper unplugged: motor current up to 1A RMS
Select motion controller	2-3 TMC429	Set jumpers to select motion controller TMC429 (on the module)
	1-2 External	Set jumpers to select external motion controller. Step/Dir Signals from external motion controller have to be connected to Step/Dir In

Table 12: Jumpers of the TMCM-1110_V23 stepRocker



6 LEDs

LED Description		
Status	Label	Description
Power on	POWER	This orange LED lights up upon the power supply is available
LED1 without pre-defined functionality	LED1	This yellow LED can be used customer specific. This LED is connected to PTA5 (pin 31) of the MK20DX128VLK7 microcontroller.
LED2 without pre-defined functionality	LED2	This yellow LED can be used customer specific. This LED is connected to PTE5 (pin 6) of the MK20DX128VLK7 microcontroller.
POSCOMP output used	POSCOMP	This yellow LED lights up if the POSCOMP output of the TMC429 is used. POSCOMP is available for triggering when moving over a programmable position.
Interrupt detected	Interrupt	This orange LED lights up upon interrupts. The LED is connected to the nIND_SDO_C pin of the TMC429.
StallGuard2™ detected	StallGuard2™	This red LED lights up upon stalling conditions. The LED is connected to the SG_TST pin of the TMC262.

Table 13: LED Description

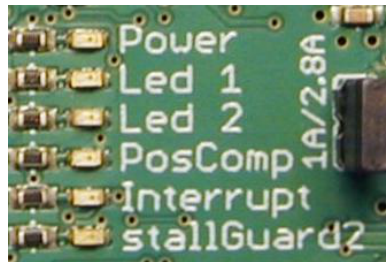

Figure 4: TMC-1110 LEDs



7 Communication

7.1 RS485

For remote control and communication with a host system the TMCM-1110_V23 provides a two wire RS485 bus interface. For proper operation the following items should be taken into account when setting up an RS485 network:

1. **BUS STRUCTURE:**

The network topology should follow a bus structure as closely as possible. That is, the connection between each node and the bus itself should be as short as possible. Basically, it should be short compared to the length of the bus.

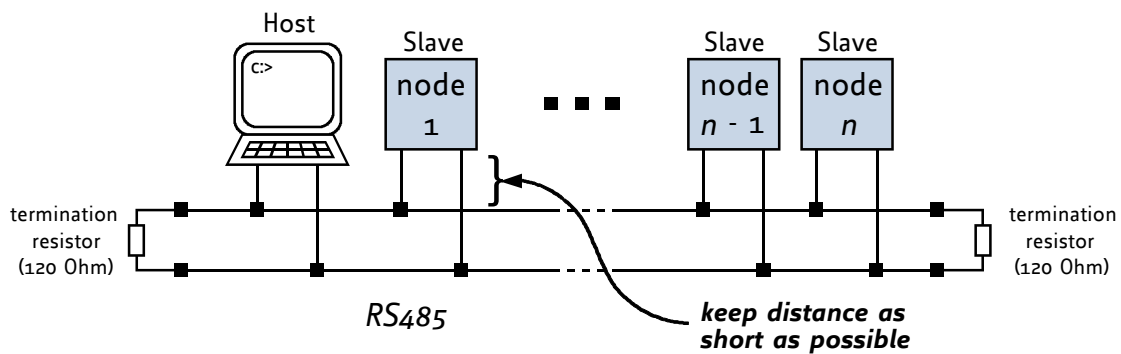

Figure 5: RS485 Bus Structure with Termination Resistors

2. **BUS TERMINATION:**

Especially for longer busses and/or multiple nodes connected to the bus and/or high communication speeds, the bus should be properly terminated at both ends. The TMCM-1110_V23 does not intergate any termination resistor. Therefore, 120 Ohm termination resistors at both ends of the bus have to be added externally.

3. **NUMBER OF NODES:**

The RS485 electrical interface standard (EIA-485) allows up to 32 nodes to be connected to a single bus. The bus transceiver used on the TMCM-1110_V23 units (SN65HVD3082ED) has just 1/8th of the standard bus load and allows a maximum of 256 units to be connected to a single RS485 bus.

4. **NO FLOATING BUS LINES:**

Avoid floating bus lines while neither the host/master nor one of the slaves along the bus line is transmitting data (all bus nodes switched to receive mode). Floating bus lines may lead to communication errors. In order to ensure valid signals on the bus it is recommended to use a resistor network connecting both bus lines to GND resp. +5V. In contrast to the termination resistors this network is normally required just once per bus. Certain RS485 interface converters available for PCs already include these additional resistors (e.g. USB-2-485).



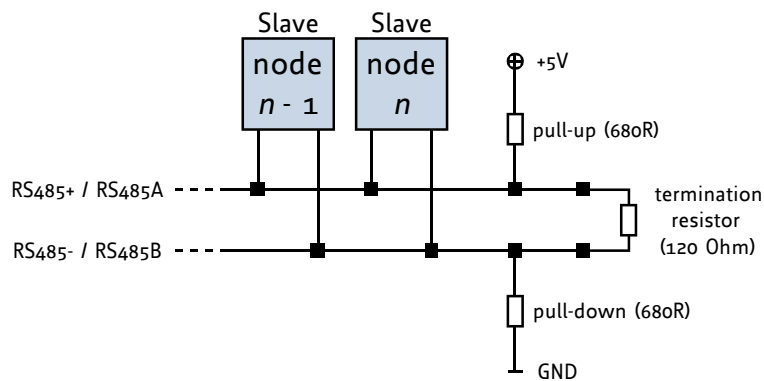

Figure 6: RS485 Bus Lines with Resistor Network

7.2 USB

For remote control and communication with a host system the TMCM-1110_V23 stepRocker provides a USB 2.0 full-speed (12Mbit/s) interface (mini-USB connector). As soon as a USB-Host is connected the module will accept commands via USB. The TMCM-1110_V23 supports USB self powered operation (External power supplied via the power supply connector) and USB bus powered operation, also (no external power is supplied via the power supply connector). During USB bus powered operation, only the core digital circuit parts will be operational. That is, the microcontroller itself and also the EEPROM. Of course, any motor movement will not be possible in this mode. This mode has been implemented in order to enable configuration / parameter setting / read-out, firmware updates etc. by just connecting a USB cable between the module and a host PC. No other connection / additional power supply is required.

7.3 CAN (Retro-fit Option)

For remote control and communication with a host system the TMCM-1110_V23 stepRocker can be equipped with a CAN bus interface. Please note, that it is necessary to add CAN transceiver and filter capacitor first for the standard TMCM-1110_V23 stepRocker version (see 4.5.1).

For proper operation the following items should be taken into account when setting up a CAN network:

1. BUS STRUCTURE:

The network topology should follow a bus structure as closely as possible. That is, the connection between each node and the bus itself should be as short as possible. Basically, it should be short compared to the length of the bus.

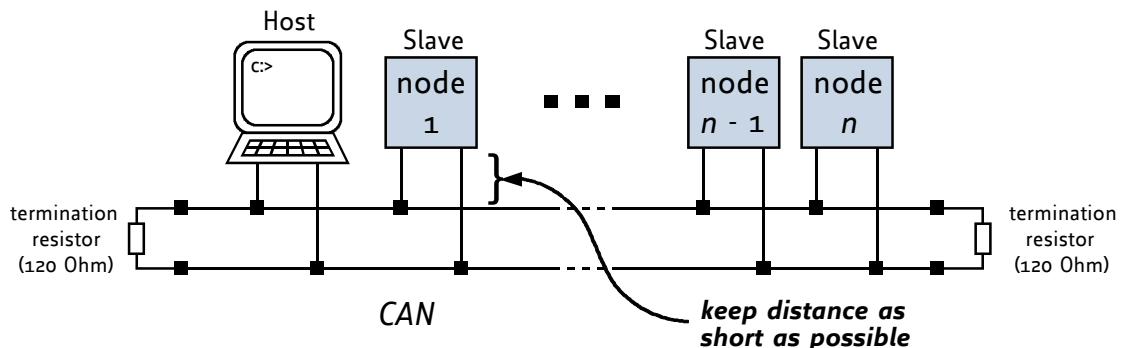

Figure 7: CAN Bus Structure with Termination Resistors



2. *BUS TERMINATION:*

Especially for longer busses and/or multiple nodes connected to the bus and/or high communication speeds, the bus should be properly terminated at both ends. The TMCM-1110_V23 does not integrate any termination resistor. Therefore, 120 Ohm termination resistors at both ends of the bus have to be added externally.



8 Functional Description

The TMCM-1110_V23 is a highly integrated single axis controller/driver module for stepper motors. The TMCM-1110_V23 can be controlled via RS485 or USB serial interfaces (CAN retro-fit option).

The TMCM-1110_V23 comes with the PC based software development environment TMCL-IDE for the Trinamic Motion Control Language (TMCL™). Using predefined TMCL™ high level commands like *move to position* a rapid and fast development of motion control applications is guaranteed. Whereas the boot loader is installed during production and testing at TRINAMIC and remains usually untouched throughout the whole lifetime, the firmware can be updated by the user.

Communication traffic is kept low since all time critical operations, e.g. ramp calculation, are performed on-board. Full remote control of the device with feedback is possible. The firmware of the module can be updated via any of the serial interfaces.

The TMCM-1110_V23 module contains the following main components:

- Microcontroller (ARM Cortex-M4™, MK20DX128VLK7), responsible for overall control and communication
- TMC429 highly integrated 3 axes stepper motor controller. Step-/direction outputs for motor 0 connected to TMC262.
- TMC262 advanced stepper motor driver IC with StallGuard2™ and CoolStep™ with MOSFET driver stage (4x N+P power MOSFETs for bipolar stepper motor) for motor 0
- RS485 and USB transceivers
- On-board voltage regulators (+5V and +3V3) required for supply of all on-board digital circuits

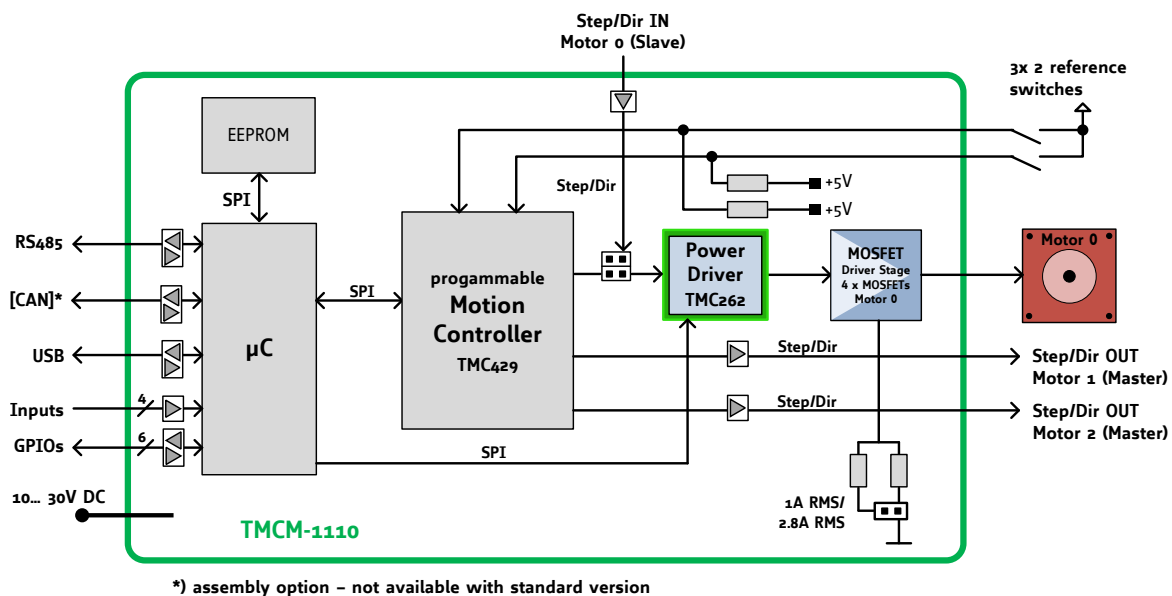

Figure 8: TMCM-1110 Block Diagram



8.1 Extensions of the TMCM-1110 stepRocker

The TMCM-1110_V23 stepRocker can be extended for multi-axes systems with up-to 3 axes. The stepRocker itself can be configured as master or slave. An example for a three axes system is shown below. The stepRocker at the top is configured as master while the other two are configured as slave. In addition to jumper setting it is necessary to switch both slave controller to driver-only operation (SAP 254, 0, 1 - see TMCL firmware manual, also). Only the motion controller on the master will be used. Therefore, all motion control related commands have to be issued to the master. In contrast, driver related commands (e.g. current settings, microstep resolution) have to be issued to each board separately (or stored on each board as TMCL program).

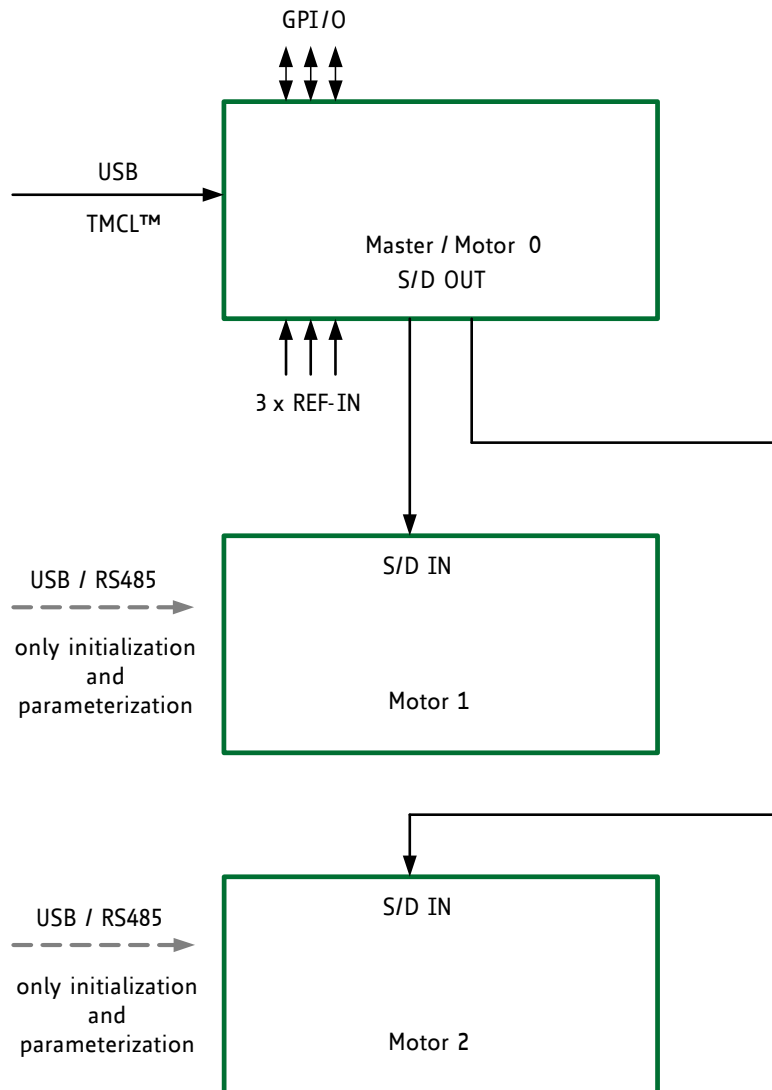

Figure 9: 3-Axes System using three stepRockers in Master/Slave Configuration



9 Operational Ratings and Characteristics

NOTICE

Never Exceed the absolute maximum ratings! Keep the power supply voltage below the upper limit of +30V! Otherwise the board electronics will seriously be damaged! Especially, when the selected operating voltage is near the upper limit a regulated power supply is highly recommended.

General Operational Ratings					
Symbol	Parameter	Min	Typ	Max	Unit
V_{Power}	Power supply voltage	10	12...24	30	V
V_{USB}	Power supply via USB connector		5		V
I_{USB}	Current withdrawn from USB supply when USB bus powered (no other supply connected)		70		mA
I_{COIL}	Motor coil current for sine wave peak (chopper regulated, adjustable via software)	0		1500 or 4000	mA
I_{MC}	Continuous motor current (RMS)	0		1000 or 2800	mA
T_{ENV}	Environmental temperature at rated current (no forced cooling required)	-25		60	°C

Table 14: General Operational Ratings of the Module

Operational Ratings of the RS485 Interface					
Symbol	Parameter	Min	Typ	Max	Unit
N_{RS485}	Number of nodes connected to single RS485 network			256	

Table 15: Operational Ratings of the RS485 Interface



10 Abbreviations used in this Manual

Abbreviation	Description
IDE	Integrated Development Environment
LED	Light Emitting Diode
RMS	Root Mean Square value
TMCL	TRINAMIC Motion Control Language

Table 16: Abbreviations used in this Manual



11 Figures Index

1	Board Dimensions and Positions of Mounting Holes (all Values in mm) . . .	5	6	RS485 Bus Lines with Resistor Network	16
2	TMC-1110 stepRocker Connectors . . .	6	7	CAN Bus Structure with Termination Resistors	16
3	Jumper Settings of the TMC-1110_V23 stepRocker	13	8	TMC-1110 Block Diagram	18
4	TMC-1110 LEDs	14	9	3-Axes System using three stepRockers in Master/Slave Configuration . .	19
5	RS485 Bus Structure with Termination Resistors	15			



12 Tables Index

1	TMCM-1110_V23 Order Code	4	10	Step/Dir Output Connector Pin Assignment	11
2	Connector Types and Mating Connectors of the TMCM-1110 stepRocker	7	11	Programming Pads on Bottom of the PCB	11
3	Power Supply Connector Pin Assignment	7	12	Jumpers of the TMCM-1110_V23 stepRocker	13
4	I/O Connector Pin Assignment	8	13	LED Description	14
5	Motor Connector Pin Assignment	8	14	General Operational Ratings of the Module	20
6	Reference Switch Connector Pin Assignment	9	15	Operational Ratings of the RS485 Interface	20
7	RS485/CAN Connector Pin Assignment	9	16	Abbreviations used in this Manual	21
8	USB Connector Pin Assignment	10	17	Hardware Revision	26
9	Step/Dir Input Connector Pin Assignment	11	18	Document Revision	26



13 Supplemental Directives

13.1 Producer Information

13.2 Copyright

TRINAMIC owns the content of this user manual in its entirety, including but not limited to pictures, logos, trademarks, and resources. © Copyright 2021 TRINAMIC. All rights reserved. Electronically published by TRINAMIC, Germany.

Redistributions of source or derived format (for example, Portable Document Format or Hypertext Markup Language) must retain the above copyright notice, and the complete Datasheet User Manual documentation of this product including associated Application Notes; and a reference to other available product-related documentation.

13.3 Trademark Designations and Symbols

Trademark designations and symbols used in this documentation indicate that a product or feature is owned and registered as trademark and/or patent either by TRINAMIC or by other manufacturers, whose products are used or referred to in combination with TRINAMIC's products and TRINAMIC's product documentation.

This Hardware Manual is a non-commercial publication that seeks to provide concise scientific and technical user information to the target user. Thus, trademark designations and symbols are only entered in the Short Spec of this document that introduces the product at a quick glance. The trademark designation /symbol is also entered when the product or feature name occurs for the first time in the document. All trademarks and brand names used are property of their respective owners.

13.4 Target User

The documentation provided here, is for programmers and engineers only, who are equipped with the necessary skills and have been trained to work with this type of product.

The Target User knows how to responsibly make use of this product without causing harm to himself or others, and without causing damage to systems or devices, in which the user incorporates the product.

13.5 Disclaimer: Life Support Systems

TRINAMIC Motion Control GmbH & Co. KG does not authorize or warrant any of its products for use in life support systems, without the specific written consent of TRINAMIC Motion Control GmbH & Co. KG.

Life support systems are equipment intended to support or sustain life, and whose failure to perform, when properly used in accordance with instructions provided, can be reasonably expected to result in personal injury or death.

Information given in this document is believed to be accurate and reliable. However, no responsibility is assumed for the consequences of its use nor for any infringement of patents or other rights of third parties which may result from its use. Specifications are subject to change without notice.

13.6 Disclaimer: Intended Use

The data specified in this user manual is intended solely for the purpose of product description. No representations or warranties, either express or implied, of merchantability, fitness for a particular purpose



or of any other nature are made hereunder with respect to information/specification or the products to which information refers and no guarantee with respect to compliance to the intended use is given.

In particular, this also applies to the stated possible applications or areas of applications of the product. TRINAMIC products are not designed for and must not be used in connection with any applications where the failure of such products would reasonably be expected to result in significant personal injury or death (safety-Critical Applications) without TRINAMIC's specific written consent.

TRINAMIC products are not designed nor intended for use in military or aerospace applications or environments or in automotive applications unless specifically designated for such use by TRINAMIC. TRINAMIC conveys no patent, copyright, mask work right or other trade mark right to this product. TRINAMIC assumes no liability for any patent and/or other trade mark rights of a third party resulting from processing or handling of the product and/or any other use of the product.

13.7 Collateral Documents & Tools

This product documentation is related and/or associated with additional tool kits, firmware and other items, as provided on the product page at: www.trinamic.com.



14 Revision History

14.1 Hardware Revision

Version	Date	Author	Description
V1.3	2013-NOV-26	GE	Series version with Samsung Cortex-M0 processor
V2.2	2016-SEP-26	GE	Processor changed to Cortex-M4 microcontroller
V2.3	2017-AUG-02	GE	Minor changes: silkscreen corrected, plating added to mounting holes and resistor values of input divider adapted in order to improve compatibility with version V1.3

Table 17: Hardware Revision

14.2 Document Revision

Version	Date	Author	Description
1.00	2011-OCT-01	GE	First version
1.01	2011-OCT-04	GE	Minor changes
1.02	2011-OCT-05	GE	Minor changes
1.03	2011-OCT-27	GE	Minor changes
1.04	2011-OCT-31	GE	Minor changes
1.05	2011-DEC-21	GE	Chapter 3.2.8 corrected: labels of Step/Dir Out 1 and Step/Dir Out 2 on PCB are exchanged. Information about USB interface corrected (3.2.6)
1.06	2011-DEC-22	GE	I/O connector information updated (3.2.2)
1.07	2012-JAN-03	GE	Minor changes
1.08	2012-APR-04	GE	Chapter 3.2.8 completed, Hint added in chapter 3.2.5.1
1.09	2017-MAY-29	GE	Major update: document format changed and update covering hardware version TMCM-1110_V22 (with new microcontroller)
1.10	2017-SEP-06	GE	Minor update: adapted to hardware revision TMCM-1110_V23
1.11	2017-OCT-10	OK	New product picture on first page.
1.12	2019-APR-03	GE	Layout correction in chapter 4.5.1.

Table 18: Document Revision

