

Hardware Version V1.2

# HARDWARE MANUAL

+



+

## TMCM-1310

1-Axis Stepper  
Closed Loop Controller / Driver  
3 A RMS / 48 V  
ABN and SSI Encoder Input  
18 GPIOs  
USB, EtherCAT®

+

+

EtherCAT®

TRINAMIC Motion Control GmbH & Co. KG  
Hamburg, Germany

[www.trinamic.com](http://www.trinamic.com)

  
**TRINAMIC**  
MOTION CONTROL  
Now part of Maxim Integrated

# Table of Contents

1	Features .....	3
2	Order Codes .....	5
3	Mechanical and Electrical Interfacing .....	6
3.1	Dimensions .....	6
3.2	Connectors .....	7
3.2.1	Power Connector .....	8
3.2.2	Motor Connector .....	8
3.2.3	Encoder Connector .....	9
3.2.4	Reference Switch Connector .....	11
3.2.5	I/O Connectors 0 and 1 .....	11
3.2.6	USB Connector .....	12
3.2.7	EtherCAT LINK IN / LINK OUT Connectors .....	13
3.3	Power Supply .....	14
3.3.1	Adding an Electrolytic Capacitor .....	14
3.4	Communication .....	15
3.4.1	USB .....	15
3.5	Inputs and Outputs .....	15
3.5.1	Encoder Input .....	15
3.5.2	Reference Switch Inputs .....	16
3.5.3	General Purpose Inputs .....	16
3.5.4	General Purpose Outputs .....	17
4	On-Board LEDs .....	18
5	Operational Ratings .....	19
6	Functional Description .....	20
7	Life Support Policy .....	21
8	Revision History .....	22
8.1	Document Revision .....	22
8.2	Hardware Revision .....	22
9	References .....	22

# 1 Features

The TMCM-1310 is a single axis stepper motor controller/driver standalone board with closed loop support. For communication an USB interface and EtherCAT®\* are provided. The module supports motor currents up to 3A RMS and supply voltages up to 48V nominal. The module offers inputs for one incremental a/b/n (TTL, open-collector and differential inputs) or absolute SSI encoders (selectable in software). There are dedicated stop switch inputs, 8 general purpose inputs, and 8 general purpose outputs.

## MAIN CHARACTERISTICS

### Bipolar stepper motor driver

- Up to 256 microsteps per full step
- High-efficient operation, low power dissipation
- Dynamic current control
- Integrated protection: overtemperature and undervoltage
- stallGuard2™ feature for stall detection ( for open loop operation)

### Encoder

- Encoder input for incremental a/b/n (TTL, open-collector and differential inputs) and absolute SSI encoders (selectable in software)

### Interfaces

- USB 2.0 full-speed (12Mbit/s) communication interface (mini-USB connector)
- EtherCAT LINK IN and LINK OUT (RJ45)
- Dedicated STOP\_L / STOP\_R inputs
- Up to 8 multi-purpose inputs (+24V compatible, incl. 2 dedicated analog inputs)
- Up to 8 multi-purpose outputs (open-drain, incl. 2 outputs for currents up to 1A)

### Software

- TMCL™ remote (direct mode) and standalone operation with memory for up to 1024 TMCL commands
- Closed-loop support
- Fully supported by TMCL-IDE (PC based integrated development environment)

### Electrical data

- Supply voltage: +12V... +48V DC
- Motor current: up to 3A RMS (programmable)

### Mechanical data

- Size: 110mm x 110mm, height 26.3mm

Please refer to separate TMCM-1310 TMCL Firmware Manual for additional information.

\* EtherCAT® is registered trademark and patented technology, licensed by Beckhoff Automation GmbH, Germany.

## TRINAMICS UNIQUE FEATURES – CLOSED LOOP MODE

The TMCM-1310 is mainly designed to run 2-phase stepper motors in closed loop mode. It offers an automatic motor load adaption in positioning mode, velocity mode, and torque mode, which is based on encoder feedback and closed loop control software for analysis, error detection and error correction.

The closed loop mode operation combines the advantages of a stepper driver system with the benefits of a servo drive. Thus, the TMCM-1310 is able to satisfy ambitious requirements in reliability and precision and can be used in several industrial demanding applications.

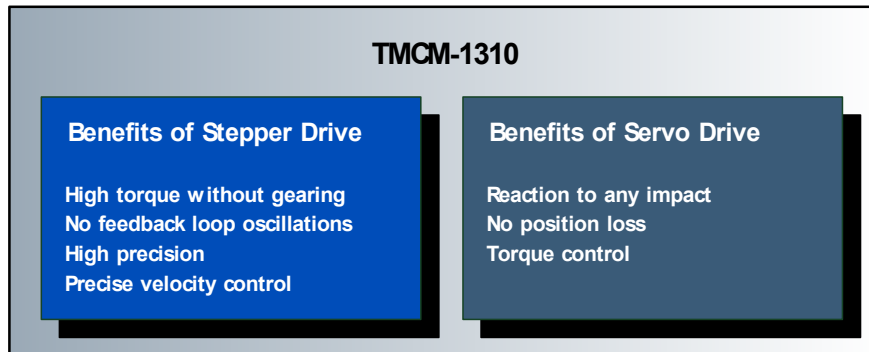

Figure 1.1 TMCM-1310 characteristics in closed loop mode

## THE TRINAMIC CLOSED LOOP MODE OPERATION

- prevents the motor from stall and step loss caused by too high load or high velocity.
- adapts the current amplitude to each motor load which is within the ranges predetermined by motor and controller/driver board characteristics.
- achieves a higher torque output than in open loop mode.
- guarantees a precise and fast positioning.
- enables velocity and positioning error compensation.

Using the TMCM-1310, energy will be saved and the motor will be kept cool.

## 2 Order Codes

Order code	Description	Size of unit (mm <sup>3</sup> )
TMCM-1310- <i>option</i>	1-axis closed-loop bipolar stepper motor controller / driver module	110 x 110 x 26.5

**Table 2.1 Order codes**

The following options are available:

Firmware option	Description	Order code example:
-TMCL	Module pre-programmed with TMCL firmware	TMCM-1310- <i>TMCL</i>

**Table 2.2 Firmware options**

A cable loom set is available for this module:

Order code	Description
TMCM-1310-CABLE	Cable loom for TMCM-1310. Contains (see chapter 3.2, also): <ul style="list-style-type: none"> <li>- 1x cable loom for power connector</li> <li>- 1x cable loom for reference switch connector</li> <li>- 1x cable loom for encoder input connector</li> <li>- 1x cable loom for motor connector</li> <li>- 2x cable loom for I/O connector 0+1</li> <li>- 1x USB type A connector to mini-USB type B connector cable</li> <li>- 1x cable loom for EtherCAT communication</li> </ul>

**Table 2.3 Cable loom order code**

### 3 Mechanical and Electrical Interfacing

#### 3.1 Dimensions

The TMCM-1310 has an overall size of 110mm x 110mm and offers four mounting holes with 4mm diameter. Maximum height (without mating connectors and cable looms) is about 26.3mm.

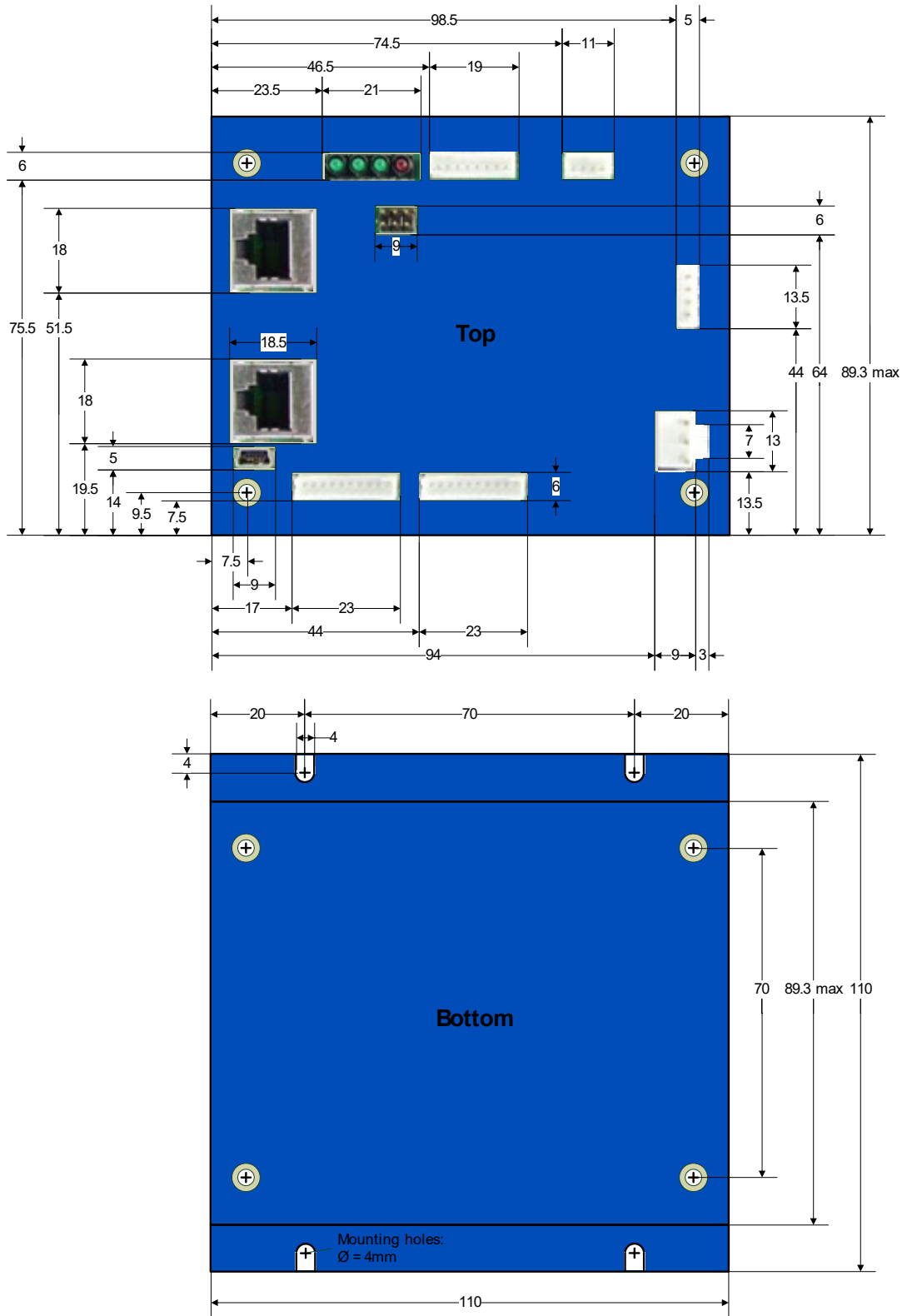

Figure 3.1 Dimensions of TMCM-1310 (all values in mm)

### 3.2 Connectors

The TMCM-1310 has nine connectors altogether:

- one detachable connector for the motor
- one detachable connector for the corresponding encoder input
- one detachable connector for the reference switches
- two detachable I/O connectors
- one detachable power connector
- two connectors for communication via EtherCAT®
- one mini-USB connector

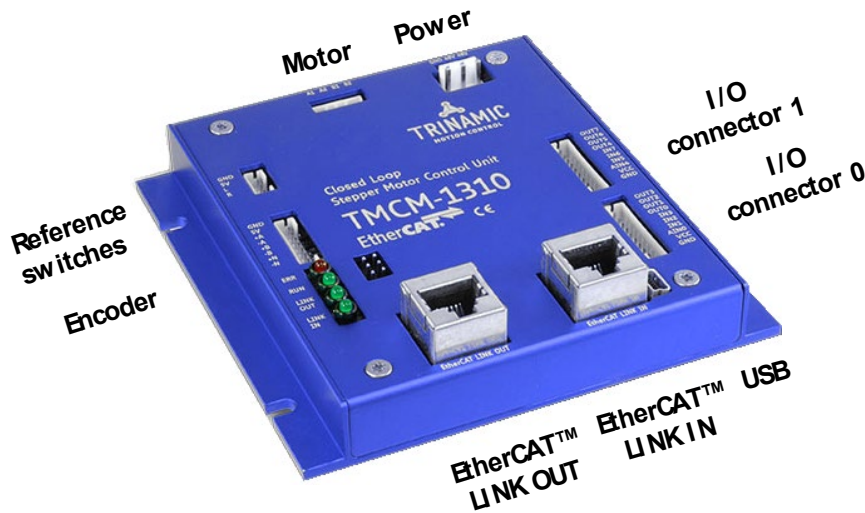

Figure 3.2 TMCM-1310 connectors

#### OVERVIEW OF CONNECTOR AND MATING CONNECTOR TYPES

Label	Connector type	Mating connector type
Power connector	JST B3P-VH (JST VH series, 3pins, 3.96mm pitch)	Connector housing: JST VHR-3N Contacts: JST SVH-21T-P1.1 Wire: 0.83mm <sup>2</sup> , AWG 18
Motor connector	JST B4B-EH-A (JST EH series, 4pins, 2.5mm pitch)	Connector housing: JST EHR-4 Contacts: JST SEH-001T-P0.6 Wire: 0.33mm <sup>2</sup> , AWG 22
Encoder connector	JST B8B-PH-K-S (JST PH series, 4pins, 2mm pitch)	Connector housing: JST PHR-8 Contacts: JST SPH-002T-P0.5S Wire: 0.22mm <sup>2</sup> , AWG 24
Reference switch connector	JST B4B-PH-K-S (JST PH series, 4pins, 2mm pitch)	Connector housing: JST PHR-4 Contacts: JST SPH-002T-P0.5S Wire: 0.22mm <sup>2</sup> , AWG 24
I/O connector 0 + 1	JST B10B-PH-K-S (JST PH series, 10pins, 2mm pitch)	Connector housing: JST PHR-10 Contacts: JST SPH-002T-P0.5S Wire: 0.22mm <sup>2</sup> , AWG 24
Mini-USB connector	Molex 500075-1517 Mini USB Type B vertical receptacle	Any standard mini-USB plug
EtherCAT™ LINK IN / OUT connectors	100BASE-TX RJ-45 connector	Any standard RJ-45 plug (adequate for 100Mbit/s Ethernet communication, e.g. CAT-5, CAT-5e or better)

Table 3.1 Connectors and mating connectors, contacts and applicable wire

### 3.2.1 Power Connector

The module has a single power connector with the option to have separate supplies for driver electronics and the digital controller part. A single supply voltage is sufficient. All further voltages required e.g. for the digital components are generated on-board.

	Pin	Label	Direction	Description
	1	GND	Power (GND)	Common system supply and signal ground
	2	V <sub>DRIVER</sub>	Power (supply input)	Stepper driver supply voltage. Without this voltage the stepper driver and any motor connected will not be energized.
	3	V <sub>DIGITAL</sub>	Power (supply input)	Supply voltage for everything else apart from the stepper motor driver. The on-board voltage regulator generates the necessary voltages for the digital circuits from this supply. The pin can be left unconnected. In this case a diode between V <sub>DRIVER</sub> and V <sub>DIGITAL</sub> ensures the supply for the digital parts. <b>ATTENTION:</b> <ul style="list-style-type: none"> <li>- The diode has a current rating of 3A. As V<sub>DIGITAL</sub> is available at the I/O connectors and at the reference switch connectors also, always connect this pin to positive supply voltage in case substantial amount of current is withdrawn from these pins for external circuits.</li> <li>- It is expected that V<sub>DIGITAL</sub> and V<sub>DRIVER</sub> are connected to the same power supply output when both pins are used. Otherwise please ensure that V<sub>DIGITAL</sub> is always equal or higher than V<sub>DRIVER</sub> when connected (due to the diode).</li> </ul>

Table 3.2 Power connector

### 3.2.2 Motor Connector

A 4 pin JST EH series connector is available for motor connection.

	Pin	Label	Direction	Description
	1	A1	Output	Pin 1 of motor coil A
	2	A2	Output	Pin 2 of motor coil A
	3	B1	Output	Pin 1 of motor coil B
	4	B2	Output	Pin 2 of motor coil B

Table 3.3 Motor connector



### 3.2.3 Encoder Connector

An encoder input connector (JST PH series 8pin with 2mm pitch) is available. There are possibilities for different encoder types. In addition to encoders with incremental A/B/N signals, encoders with synchronous serial interface (SSI) delivering absolute position information are supported, too.

#### 3.2.3.1 Encoders with Incremental A/B/N Interface Configuration

The following encoders are supported in incremental A/B/N interface configuration:

- encoders with incremental differential (RS422) output signals with or without zero/index channel
- encoders with incremental single ended (TTL or open collector) output signals with or without zero/index channel

	Pin	Label	Direction	Description
	1	GND	Power (GND)	Signal and system ground
	2	+5V	Power (supply output)	+5V output for external circuit
	3	A+	Input	Encoder channel A+ input (differential, non-inverting)
	4	A-	Input	Encoder channel A- input (differential, inverting)
	5	B+	Input	Encoder channel B+ input (differential, non-inverting)
	6	B-	Input	Encoder channel B- input (differential, inverting)
	7	N+	Input	Encoder zero / index channel input (differential, non-inverting)
	8	N-	Input	Encoder zero / index channel input (differential, inverting)

**Table 3.4 Encoder connector (configuration for encoders with incremental A/B/N output)**

For encoders with +5V supply the required +5V output is also available via this connector (max. 100mA per connector).

##### 3.2.3.1.1 Differential A/B/N Encoder Signals

For differential encoder signals connect all differential signals (A+ and A-, B+ and B- and optional N+ and N-) to the respective connector input pins. Usually on-board line termination should be also installed for differential signals. Therefore, close all three jumpers for the 120R line termination of the respective differential encoder input.

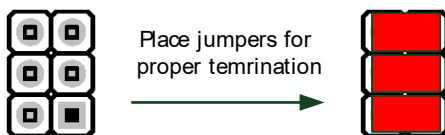

*Please refer to the encoder manufacturer data sheet for the correct interface settings.*

**Figure 3.3 Encoder input termination**

##### 3.2.3.1.2 Single Ended A/B/N Encoder Signals

For single ended encoders (TTL or open collector signals) connect the encoder signals A, B and optional N to the positive / non-inverting differential inputs of the encoder connector A+ / B+ / N+.

NECESSARY CONNECTIONS			
Encoder sign.	Encoder connector		
	Pin	Label	Description
A	3	A+	Encoder channel A
B	5	B+	Encoder channel B
N/I (optional)	7	N+	Encoder zero / index channel input

**Table 3.5 How to connect single ended encoders**

*The pins A-, B-, and N- of the encoder connector should be left unconnected.*

### 3.2.3.2 Encoders with Synchronous Serial Interface

The TMCM-1310 supports encoders with synchronous serial interface (SSI) delivering absolute position information, too. In this case the encoder connector pin assignment can be switched to its alternate function as shown in Table 3.6.

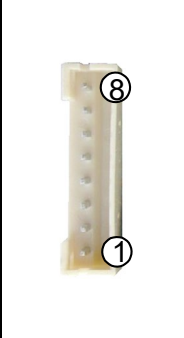
	Pin	Label	Direction	Description
	1	GND	Power (GND)	Signal and system ground
2	+5V	Power (supply output)	+5V output for external circuit	
3	CS+	Output	Encoder SSI chip select output (differential, non-inverting)	
4	CS-	Output	Encoder SSI chip select output (differential, inverting)	
5	DATA+	Input	Encoder SSI data input (differential, non-inverting)	
6	DATA-	Input	Encoder SSI data input (differential, inverting)	
7	CLOCK+	Output	Encoder SSI clock output (differential, non-inverting)	
8	CLOCK-	Output	Encoder SSI clock output (differential, inverting)	

**Table 3.6 Encoder connector (configuration for encoders with SSI output)**

#### 3.2.3.2.1 Differential SSI Encoder Signals

For differential encoder SSI signals please connect all differential signals (DATA+ and DATA-, CLOCK+ and CLOCK-) to the respective connector input pins. The CS+ and CS- signals are optional depending on encoder interface. Usually on-board line termination should be also installed for differential signals. Therefore close all three jumpers for 120R line termination of the respective differential encoder input.

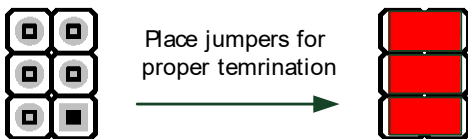

*Please refer to the encoder manufacturer data sheet for the correct interface settings.*

**Figure 3.3 Encoder input termination**

#### 3.2.3.2.2 Single Ended SSI Encoder Signals

For single ended encoders (TTL or open collector signals) please connect the encoder signals DATA and CLOCK to the positive / non-inverting differential inputs of the encoder connector DATA+ / CLOCK+. If available, encoder input signal CS should be connected to CS+.

NECESSARY CONNECTIONS			
Encoder sign.	Encoder connector		
	Pin	Label	Description
CS	3	CS+	Encoder chip select output
DATA	5	DATA+	Encoder DATA+ input
CLOCK	7	CLOCK+	Encoder CLOCK+ output

**Table 3.7 How to connect single ended SSI encoders**

*Pins CS-, DATA- and CLOCK- of the encoder connector may be left unconnected.*

### 3.2.4 Reference Switch Connector

A separate reference / limit switch input connector is available. Connector type is JST PH series 4pin with 2mm pitch.

	Pin	Label	Direction	Description
	1	GND	Power (GND)	Signal and system ground
	2	+5V	Power (supply output)	+5V supply output for external encoder and reference switch circuit.
	3	REF_L	Input	Input for reference / limit switch left
	4	REF_R	Input	Input for reference / limit switch right

Table 3.8 Reference switch connector

### 3.2.5 I/O Connectors 0 and 1

The module offers two I/O connectors (JST PH series 8pin with 2mm pitch). Number and type of inputs, outputs and supply are the same for both connectors. It is sufficient to use just one connector if only few I/Os are required. This simplifies cabling.

#### 3.2.5.1 I/O Connector 0

	Pin	Label	Direction	Description
	1	GND	Power (GND)	GND
	2	VCC	Power (supply output)	Connected to V <sub>DIGITAL</sub> of Power connector. Please note: max. current is 500mA (protected via on-board 500mA polyfuse)
	3	AIN0	Input	Dedicated analog input, input voltage range: 0... +10V, resolution: 12bit (0... 4095)
	4	IN1	Input	Digital input (+24V compatible)
	5	IN2	Input	Digital input (+24V compatible)
	6	IN3	Input	Digital input (+24V compatible)
	7	OUT0	Output	Open-drain output (max. 100mA) Integrated freewheeling diode
	8	OUT1	Output	Open-drain output (max. 100mA) Integrated freewheeling diode
	9	OUT2	Output	Open-drain output (max. 100mA) Integrated freewheeling diode
10	OUT3	Output	Open-drain output (max. 1A) Integrated freewheeling diode	

Table 3.9 I/O connector 0

### 3.2.5.2 I/O Connector 1

	Pin	Label	Direction	Description
	1	GND	Power (GND)	GND
	2	VCC	Power (supply output)	Connected to V <sub>DIGITAL</sub> of Power connector. Please note: max. current is 500mA (protected via on-board 500mA polyfuse)
	3	AIN4	Input	Dedicated analog input, input voltage range: 0... +10V, resolution: 12bit (0... 4095)
	4	IN5	Input	Digital input (+24V compatible)
	5	IN6	Input	Digital input (+24V compatible)
	6	IN7	Input	Digital input (+24V compatible)
	7	OUT4	Output	Open-drain output (max. 100mA) Integrated freewheeling diode
	8	OUT5	Output	Open-drain output (max. 100mA) Integrated freewheeling diode
	9	OUT6	Output	Open-drain output (max. 100mA) Integrated freewheeling diode
10	OUT7	Output	Open-drain output (max. 1A) Integrated freewheeling diode	

Table 3.10 I/O connector 1

### 3.2.6 USB Connector

An USB (device) interface is available via a mini-USB connector. This module supports USB 2.0 full-speed (12Mbit/s) connections.

The on-board digital core logic (mainly processor and EEPROM) will be powered via USB in case no other power supply is connected. This is useful for setting parameters and downloading TMCL programs or for performing firmware updates. Using a USB connection to the host, the tasks outlined above can be carried out inside a machine while the machine is powered off. Refer to chapter 3.4.1, please.

	Pin	Label	Direction	Description
	1	VBUS	Power (+5V input)	+5V supply from Host
	2	D-	Bi-directional	USB Data -
	3	D+	Bi-directional	USB Data +
	4	ID		Connected to signal and system ground
5	GND	Power (GND)	Signal and System ground	

Table 3.11 USB connector

### 3.2.7 EtherCAT LINK IN / LINK OUT Connectors

The TMCM-1310 offers two connectors (100BASE-TX RJ-45) with standard Ethernet 100Mbit/s pin assignment for EtherCAT LINK IN (towards Master) and LINK OUT (further slaves) connection.



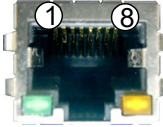

	Pin	Label	Direction	Description
	1	TX+	Output	Transmit data output (non-inverting)
	2	TX-	Output	Transmit data output (inverting)
	3	RX+	Input	Receive data input (non-inverting)
	4			
	5			
	6	RX-	Input	Receive data input (inverting)
	7			
	8			

**Table 3.12 100BASE-TX RJ-45 connector**

### 3.3 Power Supply

For proper operation care has to be taken with regard to power supply concept and design. The TMCM-1310 includes about 40µF of supply filter capacitors. These are ceramic capacitors which have been selected for high reliability and long life time. Further, the module includes a 48V suppressor diode and additional varistor for over-voltage protection.

**CAUTION!**

	<p><b>Add external power supply capacitors!</b></p> <p>The module contains a number of capacitors for power supply filtering. Nevertheless, depending on operation and selected motors the resulting capacity might be not large enough for proper supply buffering. Note: upper supply voltage limit must not be exceeded – not even for a short period of time! In this context it should be taken into account that the module will transfer energy from the motor back into the supply rail when the motor is working as generator e.g. during deceleration or brake conditions. In case the power supply capacitors are not sufficient for limiting power supply rising, additional measures have to be considered (e.g. suppressor diodes, brake resistor). Refer to chapter 3.3.1 for further information about adding electrolytic capacitors.</p>
	<p><b>Do not connect or disconnect motor during operation!</b></p> <p>Motor cable and motor inductivity might lead to voltage spikes when the motor is disconnected / connected while energized. These voltage spikes might exceed voltage limits of the driver MOSFETs and might permanently damage them. Therefore, always disconnect power supply before connecting / disconnecting the motor.</p>
	<p><b>Keep the power supply voltage below the upper limit of 52.5V!</b></p> <p>Otherwise the driver electronics will seriously be damaged! Especially, when the selected operating voltage is near the upper limit a regulated power supply is highly recommended.</p>
	<p><b>There is no reverse polarity protection!</b> The module will short any reversed supply voltage due to internal diodes of the driver transistors.</p>

#### 3.3.1 Adding an Electrolytic Capacitor

TRINAMIC recommends connecting an electrolytic capacitor of significant size to the power supply lines next to the TMCM-1311. As rule of thumb, around 1000µF of capacity should be added for 1A of module power supply input current.

The additional electrolytic capacitor

- serves for power stabilization (buffer) and filtering.
- reduces voltage spikes, which can occur in consequence of the combination of high inductance power supply wires and ceramic capacitors.
- limits the slew rate of the power supply voltage at the module. This is reasonable, because the low ESR (Equivalent Series Resistance) of ceramic-only filter capacitors may cause stability problems with some switching power supplies.

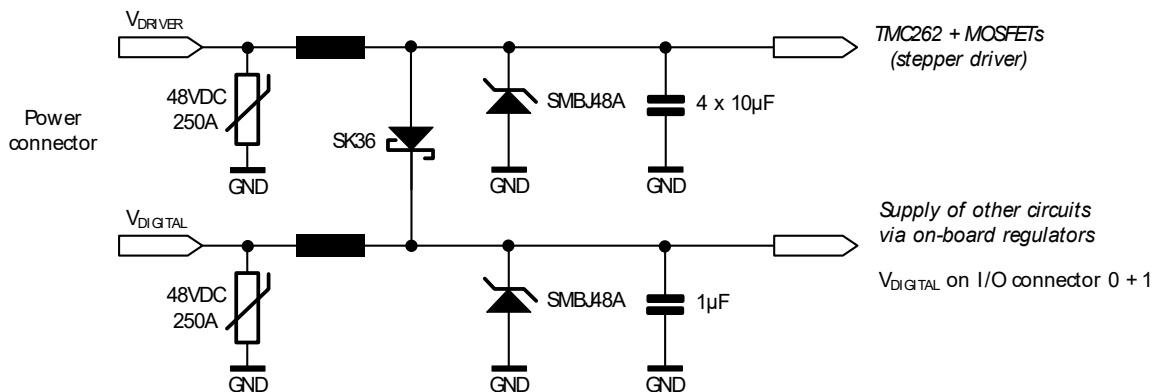

Figure 3.2 TMCM-1310 power supply concept

### 3.4 Communication

#### 3.4.1 USB

For remote control and communication with a host system the TMCM-1310 provides a USB 2.0 full-speed (12Mbit/s) interface. As soon as the USB-host is connected the module accepts commands via the USB interface. The TMCM-1310 supports USB *self powered operation* with external power supply via the power supply connector and USB *bus powered operation* without this external power supply.

#### USB BUS POWERED OPERATION

During USB bus powered operation only the core digital circuit parts - microcontroller and EEPROM - are operational. Motor movements are not possible. This mode has been implemented in order to enable configuration, parameter setting, read-out, firmware updates, etc. by connecting an USB cable between the module and an USB-host. No additional cabling or external devices (e.g. power supply) are required.

Please note that the module might draw current from the USB +5V bus supply even in USB self powered operation. This depends on the voltage level of this supply.

### 3.5 Inputs and Outputs

#### 3.5.1 Encoder Input

The encoder connector offers support either for connection of an incremental encoder with A/B signals and an optional N/I-channel or for connection of an absolute position encoder with SSI interface. Encoders with +5V TTL, open-collector or differential output signals can be connected directly. A +5V output - available at one connector pin - can be used for the encoder circuit supply. The on-board +5V switching voltage regulator has been designed to provide a maximum of 100mA for external circuits. This 100mA supply is intended for the operation of an external encoder and for the reference switch circuit, also.

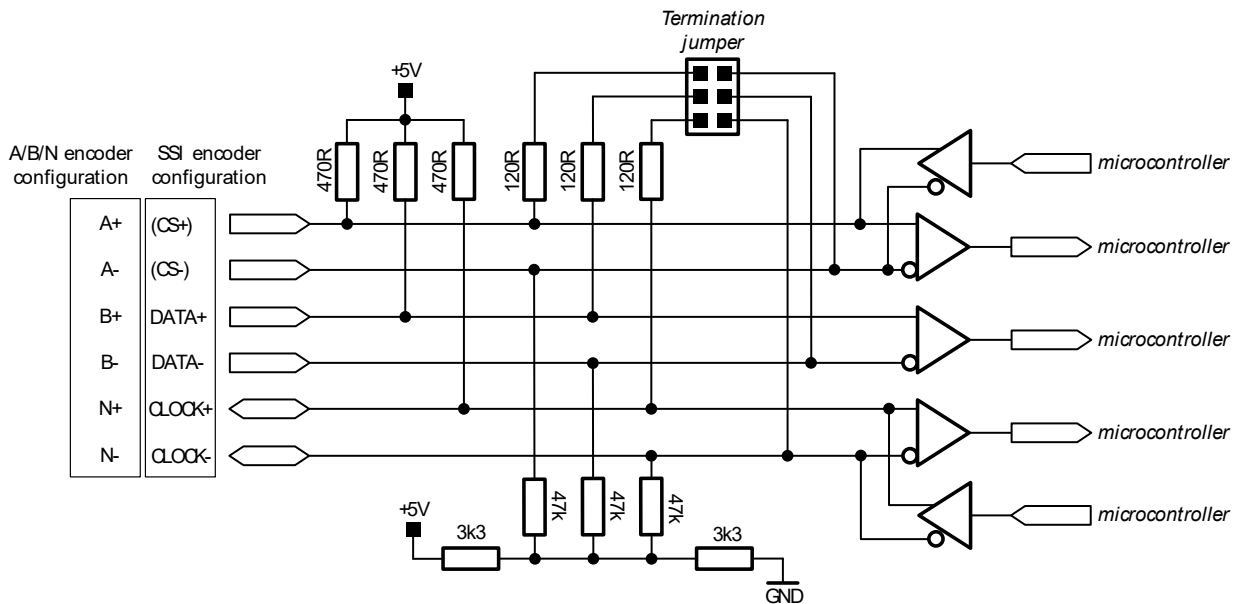

Figure 3.3 Encoder input circuit (simplified diagram)

### 3.5.2 Reference Switch Inputs

The reference switch connector provides two reference/limit switch inputs, REF\_L and REF\_R. Both inputs offer the same input circuit including voltage resistor dividers, limiting diodes against over- and under-voltage, and programmable 1k pull-ups to +5V. The programmable pull-ups can be switched on or off in software (both together).

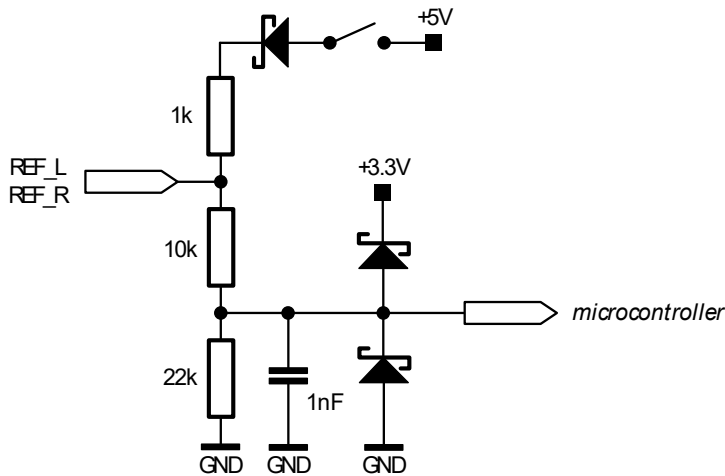

Figure 3.4 Reference switch input circuit (simplified diagram)

### 3.5.3 General Purpose Inputs

The TMCM-1310 has two I/O connectors with 8 inputs altogether including two dedicated analog inputs. All inputs offer the same basic input protection circuit, but digital and analog inputs have different input voltages: the digital inputs have been designed for +5V and +24V signal levels. The analog inputs have different input voltage dividers in order to support a full scale input voltage range of 0... +10V.

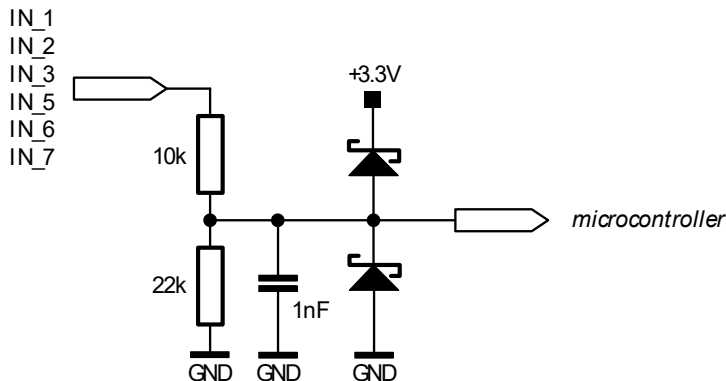

Figure 3.5 General purpose digital input circuit

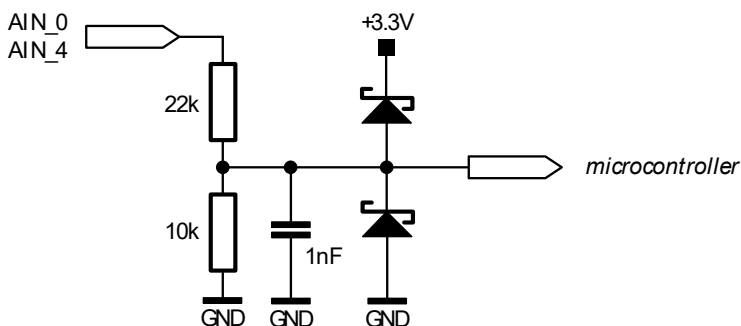

Figure 3.6 General purpose analog input circuit

The function of the inputs might differ depending on the firmware version.



### 3.5.4 General Purpose Outputs

The TMC1310 offers two I/O connectors with 8 outputs altogether. All outputs are open-drain outputs and a freewheeling diode (to  $V_{\text{DIGITAL}}$ ) is already integrated. Six outputs are designed for currents up to 100mA and two outputs offer more powerful MOSFET driver transistors supporting currents up to 1A.

If the  $V_{\text{CC}}$  connection of the I/O connectors (connected internally to  $V_{\text{DIGITAL}}$ ) is used for the *supply of substantial current* to any external circuit, make sure to connect  $V_{\text{DIGITAL}}$  to  $V_{\text{DRIVER}}$  of the power supply connector.

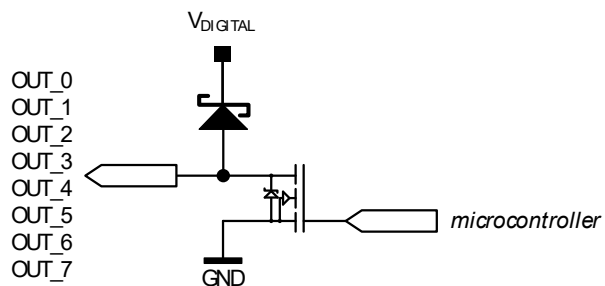

Figure 3.7 General purpose output (open-drain with freewheeling diode)

## 4 On-Board LEDs

The TMCM-1310 offers four LEDs for indicating EtherCAT communication and board status. The three green LEDs are related to the EtherCAT interface and indicate EtherCAT LINK IN and LINK OUT activity plus the status of the EtherCAT state machine. The function of the red LED is depends on the firmware version.

With standard TMCL firmware the red Error-LED should be flashing slowly during operation. When there is no valid firmware programmed into the board or during firmware update the red LED will be permanently on.

LINK IN, LINK OUT, AND STATUS OF ETHERCAT STATE MACHINE		
Green LED	Description	
EtherCAT LINK OUT state	OFF	No link.
	blinking	Link and activity.
	single flash	Link without activity.
EtherCAT LINK IN state	OFF	No link.
	blinking	Link and activity.
	single flash	Link without activity.
EtherCAT RUN state	OFF	The device is in state INIT.
	blinking	The device is in state PRE-OPERATIONAL.
	single flash	The device is in state SAFE-OPERATONAL.
	ON	The device is in state OPERATIONAL.
	flickering (fast)	The device is in state BOOTSTRAP.

Table 4.1 On-board EtherCAT LEDs



**Error**  
**EtherCAT™ RUN state**  
**EtherCAT™ LINK OUT state**  
**EtherCAT™ LINK IN state**

Figure 4.1 On-board LEDs

## 5 Operational Ratings

The operational ratings show the intended or the characteristic ranges and should be used as design values. ***In no case shall the maximum values be exceeded.***

Symbol	Parameter	Min	Typ	Max	Unit
V <sub>DRIVER</sub>	Power supply voltage for driver	10	12..24..48	52.5	V
V <sub>DIGITAL</sub>	Separate power supply voltage for controller (option, can be left unconnected)	V <sub>DRIVER</sub>			V
V <sub>USB</sub>	Power supply via USB connector		5		V
I <sub>USB</sub>	Current withdrawn from USB supply when USB bus powered (no other supply connected)		85		mA
I <sub>COIL</sub>	Motor coil current for sine wave peak (chopper regulated, adjustable via software)	0		4200	mA
I <sub>MC</sub>	Continuous motor current (RMS)	0		3	A
I <sub>S</sub>	Power supply current		<< 6x I <sub>COIL</sub>	1.4x 6x I <sub>COIL</sub>	A
T <sub>ENV@+24V</sub>	Environmental temperature at maximum current (no forced cooling) with +24V supply voltage			50	°C
T <sub>ENV@+48V</sub>	Environmental temperature at maximum current (no forced cooling) with +48V supply voltage			35	°C

**Table 5.1** General operational ratings of the module

Symbol	Parameter	Min	Typ	Max	Unit
V <sub>REF_L/R</sub>	Input voltage for reference switch inputs REF_L / REF_R	0		28	V
I <sub>REF_L/R_L</sub>	Low level voltage for reference switch inputs REF_L / REF_R	0		1.1	V
I <sub>REF_L/R_H</sub>	High level voltage for reference switch inputs REF_L / REF_R	2.9		28	V

**Table 5.2** Operational ratings of the reference switch inputs

Symbol	Parameter	Min	Typ	Max	Unit
V <sub>OUT_0..7</sub>	Voltage at open collector output	0		V <sub>DIGITAL</sub>	V
I <sub>OUT_0/1/2/4/5/6</sub>	Output sink current for OUT_0/1/2 and OUT_4/5/6			100	mA
I <sub>OUT_3/7</sub>	Output sink current for OUT_3 and OUT_7			1	A
V <sub>IN_1/2/3/5/6/7</sub>	Input voltage for general purpose digital inputs IN_1/2/3 and IN_5/6/7	0		28	V
V <sub>IN_1/1/2/3/5/6/7_L</sub>	Low level voltage for general purpose digital inputs IN_1/2/3 and IN_5/6/7	0		1.1	V
V <sub>IN_1/2/3/5/6/7_H</sub>	High level voltage for general purpose digital inputs IN_1/2/3 and IN_5/6/7	2.9		28	V
V <sub>AIN_0!4</sub>	Full scale input voltage range for analog voltage inputs	0		10	V

**Table 5.3** Operational ratings of the general purpose I/Os

## 6 Functional Description

The TMCM-1310 is a highly integrated single axis closed loop controller / driver module which can be controlled via USB or EtherCAT. Communication traffic is kept low since all time critical operations (e.g. ramp calculations) are performed on board. The preferred nominal supply voltage of the unit can be chosen out of 24V, 12V, and 48V DC. The module is designed for both, standalone operation and direct mode. Full remote control of the device with feedback is possible. The firmware of the module can be updated via any the USB interface.

In Figure 6.1 the main parts of the TMCM-1310 are shown:

- the microprocessor, which runs the TMCL operating system (connected to TMCL memory)
- the power driver with stallGuard2 and current control
- the MOSFET driver stage
- Encoder interface
- EtherCAT (RJ45) transceivers and USB interface
- On-board switching and linear voltage regulators for supply of on-board digital circuits

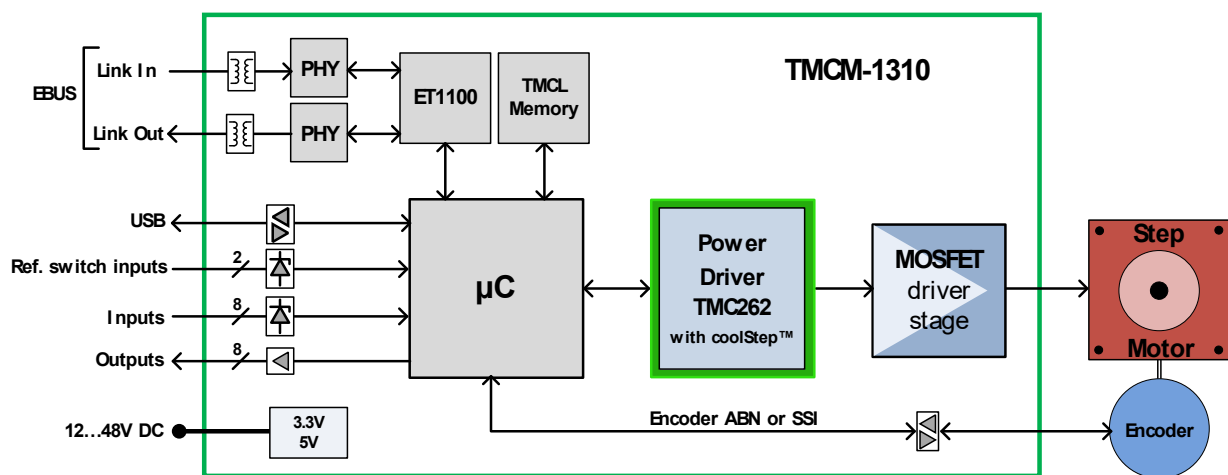

Figure 6.1 Main parts of TMCM-1310

The TMCM-1310 comes with the PC based software development environment TMCL-IDE for the TRINAMIC Motion Control Language (TMCL). Using predefined TMCL high level commands like *move to position* a rapid and fast development of motion control applications is guaranteed.

Please refer to the *TMCM-1310 Firmware Manual* for more information about TMCL commands.

## 7 Life Support Policy

TRINAMIC Motion Control GmbH & Co. KG does not authorize or warrant any of its products for use in life support systems, without the specific written consent of TRINAMIC Motion Control GmbH & Co. KG.

Life support systems are equipment intended to support or sustain life, and whose failure to perform, when properly used in accordance with instructions provided, can be reasonably expected to result in personal injury or death.

© TRINAMIC Motion Control GmbH & Co. KG 2013

Information given in this data sheet is believed to be accurate and reliable. However neither responsibility is assumed for the consequences of its use nor for any infringement of patents or other rights of third parties, which may result from its use.

Specifications are subject to change without notice.

All trademarks used are property of their respective owners.



## 8 Revision History

### 8.1 Document Revision

Version	Date	Author	Description
0.90	2012-OCT-25	GE	Preliminary version
1.00	2012-DEC-06	SD	First complete version
1.10	2013-MAY-23	GE	Adapted to latest hardware version V1.2
1.11	2013-JUL-03	SD	Changes related to the design
1.12	2013-JUL-05	SD	New front picture

Table 8.1 Document revision

### 8.2 Hardware Revision

Version	Date	Description
TMCM-1310_V10	2012-JUL-27	Initial version
TMCM-1310_V11	2013-JAN-14	Minor corrections <ul style="list-style-type: none"> <li>- USB circuit corrected</li> </ul>
TMCM-1310_V12	2013-APR-10	Several corrections and modifications: <ul style="list-style-type: none"> <li>- Additional supply input filters and enhanced protection circuit</li> <li>- Stepper motor driver stage output filter added</li> <li>- Revised ground / shield concept. Enclosure connected to shield instead of system ground</li> <li>- SSI encoder support now with separate CS (chip select) signal support</li> <li>- Option for supply current measurement</li> </ul>

Table 8.2 Hardware revision

## 9 References

[JST]	JST connector <a href="http://www.jst.com">http://www.jst.com</a>
[TMCL-IDE]	TMCL-IDE User Manual see <a href="http://www.trinamic.com">http://www.trinamic.com</a>
[TMCM-1310]	TMCM-1310 Firmware Manual see <a href="http://www.trinamic.com">http://www.trinamic.com</a>