

TMCM-1617 CoE Firmware Manual

Firmware Version V1.06 | Document Revision V1.00 • 2020-MAR-26

The TMCM-1617 is a low-weight miniaturized single axis servo drive for 3-phase BLDC motors with up to 18A RMS motor current and +24V supply. With CAN, RS485, and EtherCAT® it offers various communication options. TMCM-1617 supports incremental encoders, analog encoders, and digital hall sensors as position feedback. Customization and different housing options are possible.

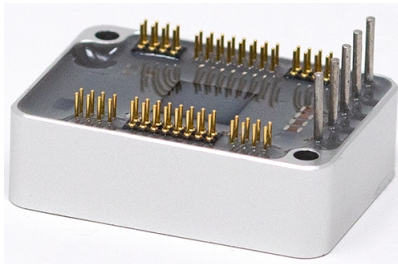

Features

- Miniaturized Servo Drive for 3-phase BLDC Motor
- +8...28V DC supply voltage (+24V nominal)
- Up to 18A RMS max. motor current
- RS485, CAN & EtherCAT® interfaces
- Incremental encoder feedback
- Digital HALL sensor feedback
- Analog encoder feedback
- Reference Switch Inputs and 6x GPIO



Applications

- Robotics
- Laboratory Automation
- Manufacturing
- Factory Automation
- Servo Drives
- Low Inductance Motors

Simplified Block Diagram

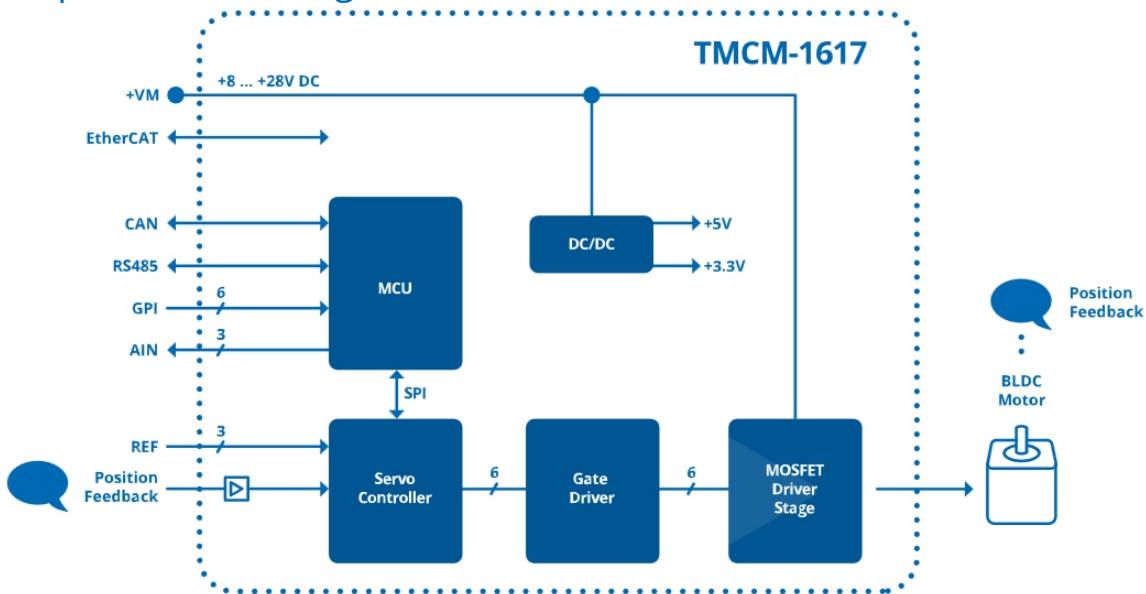

©2021 TRINAMIC Motion Control GmbH & Co. KG, Hamburg, Germany
 Terms of delivery and rights to technical change reserved.
 Download newest version at: www.trinamic.com
 EtherCAT® is a registered trademark and patented technology, licensed by Beckhoff Automation GmbH, Germany.



Contents

1	Preface	6
1.1	General Features of this CoE Implementation	6
1.2	Abbreviations used in this Manual	7
1.3	Firmware Update	7
2	Communication	8
2.1	Reference Model	8
2.2	NMT State Machine	10
2.3	Device Model	11
2.4	Object Dictionary	12
3	Communication Area	13
3.1	Detailed Object Specifications	13
3.1.1	Object 1000 _h : Device Type	13
3.1.2	Object 1001 _h : Error Register	13
3.1.3	Object 1008 _h : Manufacturer Device Name	14
3.1.4	Object 1009 _h : Manufacturer Hardware Version	14
3.1.5	Object 100A _h : Manufacturer Software Version	15
3.1.6	Object 1018 _h : Identity Object	15
3.1.7	Object 1600 _h : Receive PDO Mapping Parameter	16
3.1.8	Objects 1A00 _h : Transmit PDO Mapping Parameter	17
3.1.9	Objects 1C00 _h : Sync Manager Communication Type	17
3.1.10	Objects 1C12 _h : Sync Manager 2 PDO Assignment	18
3.1.11	Objects 1C13 _h : Sync Manager 3 PDO Assignment	19
4	Manufacturer specific Area	20
4.1	Detailed Object Specifications	20
4.1.1	Object 2000 _h : Device Info	20
4.1.2	Object 2003 _h : Maximum Current	20
4.1.3	Object 2004 _h : Open Loop Current	21
4.1.4	Object 2005 _h : Limit Switches	21
4.1.5	Object 2006 _h : Brake Chopper	22
4.1.6	Object 2041 _h : Torque Mode Settings	23
4.1.7	Object 2042 _h : Velocity Mode Settings	23
4.1.8	Object 2043 _h : Position Mode Settings	24
4.1.9	Object 2050 _h : Motor Type	24
4.1.10	Object 2055 _h : Commutation Mode	24
4.1.11	Object 2056 _h : Motor Pole Pairs	25
4.1.12	Object 2057 _h : Motor Shaft Direction	26
4.1.13	Object 2058 _h : Position Scaler	26
4.1.14	Object 2060 _h : ADC Configuration	26
4.1.15	Object 2070 _h : Hall Sensor Settings	27
4.1.16	Object 2080 _h : ABN Encoder Settings	28
4.1.17	Object 2101 _h : Motor Status Flags	28
4.1.18	Object 2102 _h : Open Loop Commutation Angle	29
4.1.19	Object 2103 _h : Encoder Commutation Angle	30
4.1.20	Object 2104 _h : Hall Commutation Angle	30
4.1.21	Object 2140 _h : Home Offset Display	31
4.1.22	Object 2702 _h : Digital Inputs	31
4.1.23	Object 2703 _h : Digital Outputs	31
4.1.24	Object 270E _h : Analog Inputs	32



5	Profile Specific Area	34
5.1	Detailed Object Specifications	34
5.1.1	Object 605A _h : Quick Stop Option Code	34
5.1.2	Object 605B _h : Shutdown Option Code	35
5.1.3	Object 605C _h : Disable Operation Option Code	35
5.1.4	Object 605D _h : Halt Option Code	36
5.1.5	Object 605E _h : Fault Reaction Option Code	36
5.1.6	Object 6060 _h : Modes of Operation	37
5.1.7	Object 6061 _h : Modes of Operation Display	38
5.1.8	Object 606A _h : Sensor Selection Code	39
5.1.9	Object 608F _h : Position Encoder Resolution	39
5.1.10	Object 60FD _h : Digital Inputs	40
5.1.11	Object 6502 _h : Supported Drive Modes	40
6	Profile Position Mode	42
6.1	Detailed Object Specifications	42
6.1.1	Object 6040 _h : Control Word	43
6.1.2	Object 6041 _h : Status Word	44
6.1.3	Object 6062 _h : Position Demand Value	45
6.1.4	Object 6063 _h : Position Actual Internal Value	46
6.1.5	Object 6064 _h : Position Actual Value	46
6.1.6	Object 6065 _h : Following Error Window	47
6.1.7	Object 6067 _h : Position Window	47
6.1.8	Object 6068 _h : Position Window Time	48
6.1.9	Object 606C _h : Velocity Actual Value	48
6.1.10	Object 607A _h : Target Position	49
6.1.11	Object 607D _h : Software Position Limit	49
6.1.12	Object 6081 _h : Profile Velocity	50
6.1.13	Object 6083 _h : Profile Acceleration	50
6.1.14	Object 6084 _h : Profile Deceleration	51
6.1.15	Object 6085 _h : Quick Stop Deceleration	51
6.1.16	Object 60F2 _h : Positioning Option Code	51
6.2	How to move a Motor in pp Mode	52
7	Profile Velocity Mode	53
7.1	Detailed Object Specifications	53
7.1.1	Object 6040 _h : Control Word	53
7.1.2	Object 6041 _h : Status Word	54
7.1.3	Object 6062 _h : Position Demand Value	56
7.1.4	Object 6063 _h : Position Actual Internal Value	56
7.1.5	Object 6064 _h : Position Actual Value	56
7.1.6	Object 6065 _h : Following Error Window	57
7.1.7	Object 606C _h : Velocity Actual Value	57
7.1.8	Object 607D _h : Software Position Limit	58
7.1.9	Object 6083 _h : Profile Acceleration	58
7.1.10	Object 6085 _h : Quick Stop Deceleration	59
7.1.11	Object 60FF _h : Target Velocity	59
7.2	How to move a Motor in pv Mode	60
8	Homing Mode	61
8.1	Homing Methods	62
8.1.1	Homing Method 17: Homing on negative Limit Switch	62
8.1.2	Homing Method 18: Homing on positive Limit Switch	62
8.1.3	Homing Method 19: Homing on positive Home Switch	63



8.1.4	Homing Method 21: Homing on negative Home Switch	63
8.1.5	Homing Method 35: Current Position as Home Position	64
8.2	Detailed Object Specifications	65
8.2.1	Object 6040 _h : Control Word	65
8.2.2	Object 6041 _h : Status Word	66
8.2.3	Object 606C _h : Velocity Actual Value	67
8.2.4	Object 607C _h : Home Offset	68
8.2.5	Object 6098 _h : Homing Method	69
8.2.6	Object 6099 _h : Homing Speeds	69
8.2.7	Object 609A _h : Homing Acceleration	69
8.3	How to start a Homing in hm Mode	70
9	Cyclic synchronous Position Mode	71
9.1	Detailed Object Specifications	71
9.1.1	Object 6040 _h : Control Word	71
9.1.2	Object 6041 _h : Status Word	72
9.1.3	Object 6062 _h : Position Demand Value	74
9.1.4	Object 6063 _h : Position Actual Internal Value	74
9.1.5	Object 6064 _h : Position Actual Value	74
9.1.6	Object 606C _h : Velocity Actual Value	75
9.1.7	Object 607A _h : Target Position	75
9.1.8	Object 607D _h : Software Position Limit	76
9.1.9	Object 60B0 _h : Position Offset	76
9.1.10	Object 60C2 _h : Interpolation Time Period	77
10	Cyclic synchronous Velocity Mode	78
10.1	Detailed Object Specifications	78
10.1.1	Object 6040 _h : Control Word	78
10.1.2	Object 6041 _h : Status Word	79
10.1.3	Object 606C _h : Velocity Actual Value	81
10.1.4	Object 60FF _h : Target Velocity	81
10.1.5	Object 607D _h : Software Position Limit	81
10.1.6	Object 60B1 _h : Velocity Offset	82
10.1.7	Object 60C2 _h : Interpolation Time Period	82
11	Cyclic synchronous Torque Mode	84
11.1	Detailed Object Specifications	84
11.1.1	Object 6040 _h : Control Word	84
11.1.2	Object 6041 _h : Status Word	85
11.1.3	Object 6062 _h : Position Demand Value	86
11.1.4	Object 6063 _h : Position Actual Internal Value	87
11.1.5	Object 6064 _h : Position Actual Value	87
11.1.6	Object 6071 _h : Target Torque	88
11.1.7	Object 6077 _h : Torque actual Value	88
11.1.8	Object 607D _h : Software Position Limit	88
11.1.9	Object 60B2 _h : Torque Offset	89
11.1.10	Object 60C2 _h : Interpolation Time Period	89
12	Emergency Messages (EMCY)	91
13	Figures Index	93
14	Tables Index	94
15	Supplemental Directives	97



15.1 Producer Information	97
15.2 Copyright	97
15.3 Trademark Designations and Symbols	97
15.4 Target User	97
15.5 Disclaimer: Life Support Systems	97
15.6 Disclaimer: Intended Use	97
15.7 Collateral Documents & Tools	98
16 Revision History	99
16.1 Firmware Revision	99
16.2 Document Revision	99



1 Preface

This document specifies objects and modes of operation of the Trinamic TMCM-1617 stepper motor control module with CANopen-over-EtherCAT (CoE) firmware. The CoE firmware is designed to fulfill the EtherCAT® version of the CANopen DS402 standards. The EtherCAT® conformance has also been tested. This manual assumes that the reader is already familiar with the basics of EtherCAT® and the CoE protocol (especially DS402).

If necessary it is always possible to turn the module into a TMCL™ or CANopen® module by loading the TMCM-1617 TMCL™ or CANopen® firmware again through the CAN or RS485 interface using the firmware update function of the TMCL-IDE 3.0.

1.1 General Features of this CoE Implementation

Main Characteristics

- Communication according to EtherCAT® standards
- Protocols: CoE, FoE

SDO Communication

- 1 server
- Expedited transfer
- Segmented transfer
- No block transfer

PDO Communication

- Producer
- Consumer
- RPDOs
 - Dynamic mapping with max. 6 mapping entries.
 - Default mappings: manufacturer specific.
- TPDOs
 - Dynamic mapping with max. 9 mapping entries.
 - Default mappings: manufacturer specific.

Sync managers

- Sync manager 0: receive mailbox used for SDO communication
- Sync manager 1: send mailbox used for SDO communication
- Sync manager 2: process data output (used for TPDO)
- Sync manager 3: process data input (used for RPDO)

Further Characteristics

- Emergency: producer



1.2 Abbreviations used in this Manual

Abbreviations	
CAN	Controller area network
CoE	CANopen over EtherCAT
CHGND	chassis ground / earth ground
COB	Communication object
FoE	File transfer over EtherCAT
FSA	Finite state automaton
FSM	Finite state machine
NMT	Network management
ID	Identifier
LSB	Least significant bit
MSB	Most significant bit
PDO	Process data object
PDS	Power drive system
RPDO	Receive process data object
SDO	Service data object
TPDO	Transmit process data object
EMCY	Emergency object
rw	Read and write
ro	Read only
hm	Homing mode
pp	Profile position mode
pv	Profile velocity mode
vm	Velocity mode

Table 1: Abbreviations used in this Manual

1.3 Firmware Update

The software running on the microprocessor consists of two parts, a boot loader and the CoE firmware itself. Whereas the boot loader is installed during production and testing at TRINAMIC and remains untouched throughout the whole lifetime, the CoE firmware can easily be updated by the user. The new firmware can either be loaded into the module via file transfer over EtherCAT (FoE) or via the firmware update function of the TMCL-IDE, using the CAN interface or the RS-485 interface of the module.



2 Communication

2.1 Reference Model

The application layer comprises a concept to configure and communicate real-time-data as well as the mechanisms for synchronization between devices. The functionality which the application layer offers to an application is logically divided over different service data objects (SDO) in the application layer. A service object offers a specific functionality and all the related services.

Applications interact by invoking services of a service object in the application layer. To realize these services this object exchanges data via the EtherCAT with peer service object(s) using a protocol.

The application and the application layer interact with service primitives.

Service Primitives	
Primitive	Definition
Request	Issued by the application to the application layer to request a service.
Indication	Issued by the application layer to the application to report an internal event detected by the application layer or indicate that a service is requested.
Response	Issued by the application to the application layer to respond to a previous received indication.
Confirmation	Issued by the application layer to the application to report the result of a previously issued request.

Table 2: Service Primitives

A service type defines the primitives that are exchanged between the application layer and the cooperating applications for a particular service of a service object. Unconfirmed and confirmed services are collectively called remote services.



Service Types	
Type	Definition
Local service	Involves only the local service object. The application issues a request to its local service object that executes the requested service without communicating with peer service object(s).
Unconfirmed service	Involves one or more peer service objects. The application issues a request to its local service object. This request is transferred to the peer service object(s) that each passes it to their application as an indication. The result is not confirmed back.
Confirmed service	Can involve only one peer service object. The application issues a request to its local service object. This request is transferred to the peer service object that passes it to the other application as an indication. The other application issues a response that is transferred to the originating service object that passes it as a confirmation to the requesting application.
Provider initiated service	Involves only the local service object. The service object (being the service provider) detects an event not solicited by a requested service. This event is then indicated to the application.

Table 3: Service Types



2.2 NMT State Machine

The finite state machine (FSM) or simply state machine is a model of behavior composed of a finite number of states, transitions between those states, and actions. It shows which way the logic runs when certain conditions are met.

Starting and resetting the device is controlled via the state machine. The NMT state machine consists of the states shown in figure 1.

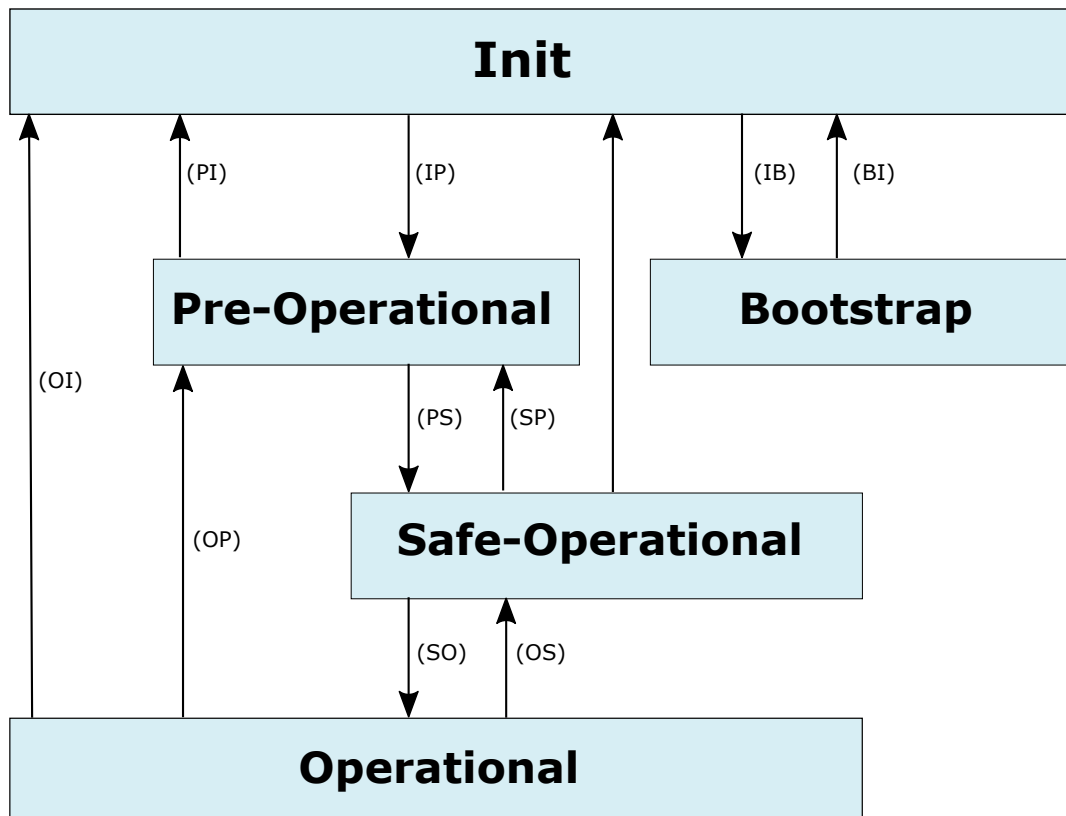

Figure 1: NMT State Machine

After power-on or reset the device enters the Initialization (**INIT**) state.

The master can then switch the device to Pre-Operational (**PRE-OP**) state. In this state, only SDO communication is possible. PDO communication is not possible.

In Safe-Operational (**SAFE-OP**) state, also PDO communication is possible. Inputs can be read, but outputs cannot be switched and the motor cannot be run.

In Operational (**OP**) state, all features of the module can be used. PDO communication is possible, outputs can be switched and the motor can be used. During Operational state the device can use all supported communication objects.

When switching from Operational to Safe-Operational state the motor will be stopped if it has been running. When the EtherCAT connection is lost during Operational state the device will also automatically



switch to Safe-Operational state.

The Bootstrap (**BOOT**) state is used for firmware updates via FoE. Before FoE can be used the device has to be switched to this state.

2.3 Device Model

A CoE device mainly consists of the following parts:

- *Communication*: This function unit provides the communication objects and the appropriate functionality to transport data items via the underlying network structure.
- *Object dictionary*: The object dictionary is a collection of all the data items which have an influence on the behavior of the application objects, the communication objects and the state machine used on this device.
- *Application*: The application comprises the functionality of the device with respect to the interaction with the process environment.

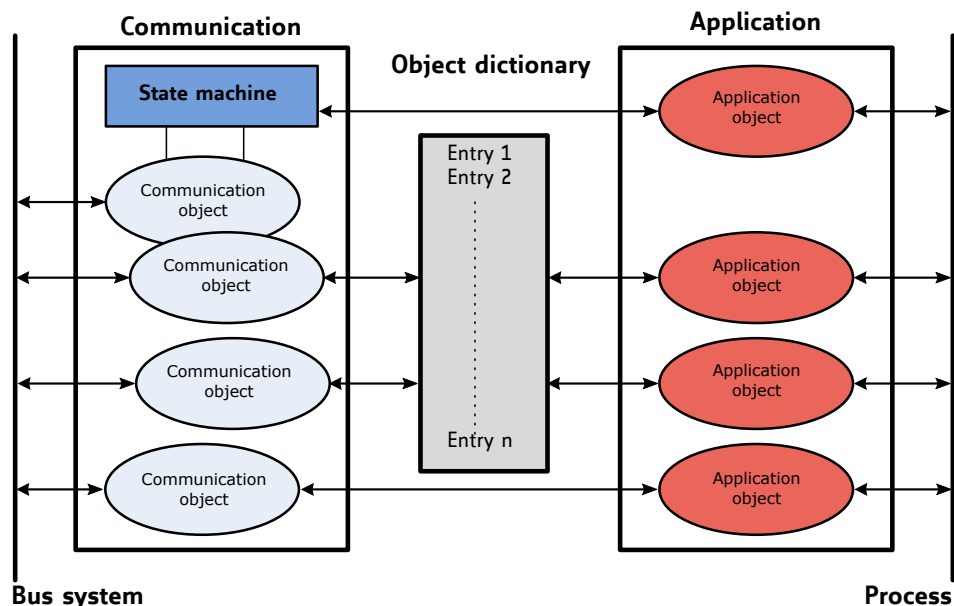

Figure 2: Device Model



2.4 Object Dictionary

The most important part of a device profile is the object dictionary description. The object dictionary is essentially a grouping of objects accessible via the network in an ordered pre-defined fashion. Each object within the dictionary is addressed using a 16-bit index. The overall layout of the standard object dictionary is shown in table 4:

Object Dictionary	
Index	Object
0000 _h	Not used.
0001 _h – 001F _h	Static data types.
0020 _h – 003F _h	Complex data types.
0040 _h – 005F _h	Manufacturer specific complex data types.
0060 _h – 007F _h	Device profile specific static data types.
0080 _h – 009F _h	Device profile specific complex data types.
00A0 _h – 0FFF _h	Reserved for further use.
1000 _h – 1FFF _h	Communication profile area.
2000 _h – 5FFF _h	Manufacturer specific profile area.
6000 _h – 9FFF _h	Standardized device profile area.
A000 _h – BFFF _h	Standardized interface profile area.
C000 _h – FFFF _h	Reserved for further use.

Table 4: Object Dictionary

The communication profile area at indices 1000_h through 1FFF_h contains the communication specific parameters for the CAN network. These entries are common to all devices.

The manufacturer segment at indices 2000_h through 5FFF_h contains manufacturer specific objects. These objects control the special features of the Trinamic TMC-1617 motion control device.

The standardized device profile area at indices 6000_h through 9FFF_h contains all data objects common to a class of devices that can be read or written via the network. They describe the device parameters and the device functionality of the device profile.



3 Communication Area

The communication area contains all objects that define the communication parameters of the CoE device according to the EtherCAT standard.

3.1 Detailed Object Specifications

3.1.1 Object 1000_h: Device Type

This object contains information about the device type. The object 1000_h describes the type of device and its functionality. It is composed of a 16-bit field which describes the device profile that is used and a second 16-bit field which provides additional information about optional functionality of the device.

Object Description			
Index	Name	Object Type	Data Type
1000 _h	Device type	Variable	UNSIGNED32

Table 5: Object Description (1000_h)

Entry Description				
Sub-index	Access	PDO Mapping	Value Range	Default Value
0	ro	no	UNSIGNED32	FFFC0192 _h

Table 6: Entry Description (1000_h)

3.1.2 Object 1001_h: Error Register

This object contains error information. The CANopen device maps internal errors into object 1001_h. It is part of an emergency object.

Object Description			
Index	Name	Object Type	Data Type
1001 _h	Error register	Variable	UNSIGNED8

Table 7: Object Description (1001_h)

Entry Description				
Sub-index	Access	PDO Mapping	Value Range	Default Value
0	ro	no	UNSIGNED8	0

Table 8: Entry Description (1001_h)



Error Register Bits	
Bit	Definition
0	Generic error
1	Current
2	Voltage
3	Temperature
4	Communication error
5	Device profile specific
6	Reserved (always 0)
7	Manufacturer specific

Table 9: Error Register Bits

3.1.3 Object 1008_h: Manufacturer Device Name

This object contains the name of the device as given by the manufacturer.

Object Description			
Index	Name	Object Type	Data Type
1008 _h	Manufacturer Device Name	Variable	Visible String

Table 10: Object Description (1008_h)

Entry Description				
Sub-index	Access	PDO Mapping	Value Range	Default Value
0	ro	no	—	TMCM-1617

Table 11: Entry Description (1008_h)

3.1.4 Object 1009_h: Manufacturer Hardware Version

This object contains the hardware version description.

Object Description			
Index	Name	Object Type	Data Type
1009 _h	Manufacturer Hardware Version	Variable	Visible String

Table 12: Object Description (1009_h)



Entry Description				
Sub-index	Access	PDO Mapping	Value Range	Default Value
0	ro	no	—	Depends on device, e.g. 1.0.

Table 13: Entry Description (1009_h)

3.1.5 Object 100A_h: Manufacturer Software Version

This object contains the software version description.

Object Description			
Index	Name	Object Type	Data Type
100A _h	Manufacturer Software Version	Variable	Visible String

Table 14: Object Description (100A_h)

Entry Description				
Sub-index	Access	PDO Mapping	Value Range	Default Value
0	ro	no	—	Depends on device, e.g. 1.0.

Table 15: Entry Description (100A_h)

3.1.6 Object 1018_h: Identity Object

The object 1018_h contains general information about the device:

- The vendor ID (sub-index 01_h) contains a unique value allocated to each manufacturer. The vendor ID of Trinamic is 286_h.
- The manufacturer specific product code (sub-index 2_h) identifies a specific device version.
- The manufacturer specific revision number (sub-index 3_h) consists of a major revision number and a minor revision number.

Object Description			
Index	Name	Object Type	Data Type
1018 _h	Identity object	Record	Identity

Table 16: Object Description (1018_h)

Entry Description					
Sub-index	Description	Access	PDO Mapping	Value Range	Default Value
00 _h	Number of entries	ro	no	0...3	3
01 _h	Vendor ID	ro	no	UNSIGNED32	0286 _h
02 _h	Product code	ro	no	UNSIGNED32	1617
03 _h	Revision number	ro	no	UNSIGNED32	e.g. 20003 _h for version 2.3

Table 17: Entry Description (1018_h)

3.1.7 Object 1600_h: Receive PDO Mapping Parameter

This object contains the mapping parameters for the RPDO the device is able to receive. The sub-index 00_h contains the number of valid entries within the mapping record. This number of entries is also the number of the application variables which shall be received with the corresponding RPDO. The sub-indices from 01_h to the number of entries contain the information about the mapped application variables. These entries describe the PDO contents by their index, sub-index and length.

Object Description			
Index	Name	Object Type	Data Type
1600 _h	Receive PDO mapping parameter	RECORD	PDO Mapping

Table 18: Object Description (1600_h)

Entry Description				
Sub-index	Description	Access	Value Range	Default Value
00 _h	Number of mapped application objects in PDO	rw	0...9	Index 1600 _h : 4
01 _h	Mapping entry 1	rw	UNSIGNED32	60400010 _h
02 _h	Mapping entry 3	rw	UNSIGNED32	607A0020 _h
03 _h	Mapping entry 4	rw	UNSIGNED32	60710010 _h
04 _h	Mapping entry 5	rw	UNSIGNED32	60FF0020 _h
05 _h	Mapping entry 2	rw	UNSIGNED32	0 _h
06 _h	Mapping entry 6	rw	UNSIGNED32	0 _h
07 _h	Mapping entry 7	rw	UNSIGNED32	0 _h
08 _h	Mapping entry 8	rw	UNSIGNED32	0 _h
09 _h	Mapping entry 9	rw	UNSIGNED32	0 _h

Table 19: Entry Description (1600_h)



3.1.8 Objects 1A00_h: Transmit PDO Mapping Parameter

This object contains the mapping parameters for the TPDO the device is able to transmit. The sub-index 00_h contains the number of valid entries within the mapping record. This number of entries is also the number of the application variables which shall be transmitted with the corresponding TPDO. The sub-indices from 01_h to the number of entries contain the information about the mapped application variables. These entries describe the PDO contents by their index, sub-index and length.

Object Description			
Index	Name	Object Type	Data Type
1A00 _h	Transmit PDO mapping parameter	RECORD	PDO Mapping

Table 20: Object Description (1A00_h)

Entry Description				
Sub-index	Description	Access	Value Range	Default Value
00 _h	Number of mapped application objects in PDO	rw	0...9	6
01 _h	Mapping entry 1	rw	UNSIGNED32	60410010 _h
02 _h	Mapping entry 2	rw	UNSIGNED32	60610008 _h
03 _h	Mapping entry 3	rw	UNSIGNED32	60640020 _h
04 _h	Mapping entry 4	rw	UNSIGNED32	60770010 _h
05 _h	Mapping entry 5	rw	UNSIGNED32	606C0020 _h
06 _h	Mapping entry 6	rw	UNSIGNED32	60FD0020 _h
07 _h	Mapping entry 7	rw	UNSIGNED32	0 _h
08 _h	Mapping entry 8	rw	UNSIGNED32	0 _h
09 _h	Mapping entry 9	rw	UNSIGNED32	0 _h

Table 21: Entry Description (1A00_h)

3.1.9 Objects 1C00_h: Sync Manager Communication Type

This object describes the communication types of the EtherCAT sync managers. The types of the first four sync managers are normally fixed and should not be changed. Sync managers can have the following for communication types:



Sync Manager Communication Types	
Type	Description
1	Mailbox receive
2	Mailbox send
3	Process data input
4	Process data output

Table 22: Sync Manager Communication Types

Object Description			
Index	Name	Object Type	Data Type
1C00 _h	Sync manager communication type	RECORD	UNSIGNED8

Table 23: Object Description (1C00_h)

Entry Description				
Sub-index	Description	Access	Value Range	Default Value
00 _h	Number of entries	rw	0...3	4
01 _h	Communication type sync manager 1	rw	UNSIGNED8	1
02 _h	Communication type sync manager 2	rw	UNSIGNED8	2
03 _h	Communication type sync manager 3	rw	UNSIGNED8	3
04 _h	Communication type sync manager 4	rw	UNSIGNED8	4

Table 24: Entry Description (1C00_h)

3.1.10 Objects 1C12_h: Sync Manager 2 PDO Assignment

This object contains the index of the PDO definition object that is assigned to sync manager 2. Normally, the RPDO objects are assigned to sync manager 2. Under most circumstances there is no need to change this setting.

Object Description			
Index	Name	Object Type	Data Type
1C12 _h	Sync manager 2 PDO assignment	RECORD	PDO assignment

Table 25: Object Description (1C12_h)



Entry Description				
Sub-index	Description	Access	Value Range	Default Value
00 _h	Number of assigned PDOs	rw	0...1	1
01 _h	PDO mapping index of assigned RPDO	rw	UNSIGNED16	1600 _h

Table 26: Entry Description (1C12_h)

3.1.11 Objects 1C13_h: Sync Manager 3 PDO Assignment

This object contains the index of the PDO definition object that is assigned to sync manager 3. Normally, the TPDO objects are assigned to sync manager 3. Under most circumstances there is no need to change this setting.

Object Description			
Index	Name	Object Type	Data Type
1C13 _h	Sync manager 3 PDO assignment	RECORD	PDO assignment

Table 27: Object Description (1C13_h)

Entry Description				
Sub-index	Description	Access	Value Range	Default Value
00 _h	Number of assigned PDOs	rw	0...1	1
01 _h	PDO mapping index of assigned TPDO	rw	UNSIGNED16	1A00 _h

Table 28: Entry Description (1C13_h)



4 Manufacturer specific Area

The manufacturer segment contains manufacturer specific objects. These objects control the special features of the Trinamic Motion Control device TMCM-1617.

4.1 Detailed Object Specifications

4.1.1 Object 2000_h: Device Info

This object provides version information about the motor controller chip used on this module.

Object Description			
Index	Name	Object Type	Data Type
2000 _h	Device Info	Variable	Record

Table 29: Object Description (2000_h)

Entry Description							
Sub-index	Name	PDO Mapping	Min	Max	Default	Unit	Access
1	MC_Type	no	0	4294967295	0	—	ro
2	MC_Version	no	0	4294967295	0	—	ro
3	MC_Date	no	0	4294967295	0	—	ro
4	MC_Time	no	0	4294967295	0	—	ro
5	MC_Variant	no	0	4294967295	0	—	ro

Table 30: Entry Description (2000_h)

4.1.2 Object 2003_h: Maximum Current

This objects limits the maximum current that is used to drive the motor. The value is given in mA.

Object Description			
Index	Name	Object Type	Data Type
2003 _h	Maximum Current	Variable	UNSIGNED32

Table 31: Object Description (2003_h)



Entry Description				
Sub-index	Access	PDO Mapping	Value Range	Default Value
0	rw	no	0...18000	0

Table 32: Entry Description (2003_h)

4.1.3 Object 2004_h: Open Loop Current

This object controls the motor current used in open loop mode. The value is given in mA.

Object Description			
Index	Name	Object Type	Data Type
2004 _h	Open Loop Current	Variable	UNSIGNED32

Table 33: Object Description (2004_h)

Entry Description				
Sub-index	Access	PDO Mapping	Value Range	Default Value
0	rw	no	0...18000	0

Table 34: Entry Description (2004_h)

4.1.4 Object 2005_h: Limit Switches

This object defines which limit switches are to be used. Bit 0 stands for the left and bit 1 stands for the right limit switch. If a bit is set, the corresponding limit switch will not be used. So this object has to be set to the value 3 if limit switches are not connected. The object can only be written when the drive is in the SWITCHED_ON_DISABLED state (but is always readable).

The limit switches can also be inverted using bit 2 and bit 3:

- Bit 2 inverts the left limit switch
- Bit 3 inverts the right limit switch

The polarity of the home switch can be set using bit 5.

Object Description			
Index	Name	Object Type	Data Type
2005 _h	Limit switches	Variable	UNSIGNED32

Table 35: Object Description (2005_h)



Entry Description				
Sub-index	Access	PDO Mapping	Value Range	Default Value
0	rw	no	0...63	0

Table 36: Entry Description (2005_h)

Bit Definitions	
Bit	Definition
0	Left limit switch deactivated if set.
1	Right limit switch deactivated if set.
2	Left limit switch inverted if set.
3	Right limit switch inverted if set.
4	Home switch deactivated if set.
5	Home switch inverted if set.

Table 37: Bit Definitions (2005_h)

4.1.5 Object 2006_h: Brake Chopper

With this object the behaviour of the brake chopper output can be set up.

Object Description			
Index	Name	Object Type	Data Type
2006 _h	Device Info	Variable	Record

Table 38: Object Description (2006_h)

Entry Description							
Sub-index	Name	PDO Mapping	Min	Max	Default	Unit	Access
1	Enable	no	0	1	0	—	RW
2	Voltage	no	0	65535	300	1/10 V	RW
3	Hysteresis	no	0	255	5	—	RW

Table 39: Entry Description (2006_h)



4.1.6 Object 2041_h: Torque Mode Settings

Object Description			
Index	Name	Object Type	Data Type
2041 _h	Torque Mode Settings	Variable	Record

Table 40: Object Description (2041_h)

Entry Description							
Sub-index	Name	PDO Mapping	Min	Max	Default	Unit	Access
1	Torque_P	no	0	65535	0		RW
2	Torque_I	no	0	65535	0		RW
3	PID_Torque_Error	no	-2147483648	2147483647	0	[mA]	R
4	PID_Torque_Error_Sum	no	-2147483648	2147483647	0		R
5	PID_Flux_Error	no	-2147483648	2147483647	0	[mA]	R
6	PID_Flux_Error_Sum	no	-2147483648	2147483647	0		R
7	PHI_E	no	-32678	32767	0		R

Table 41: Entry Description (2041_h)

4.1.7 Object 2042_h: Velocity Mode Settings

Object Description			
Index	Name	Object Type	Data Type
2042 _h	Velocity Mode Settings	Variable	Record

Table 42: Object Description (2042_h)

Entry Description							
Sub-index	Name	PDO Mapping	Min	Max	Default	Unit	Access
1	P_Parameter	no	0	65535	0		RW
2	I_Parameter	no	0	65535	0		RW
3	PI_Velocity_Error	no	-2147483648	2147483647	0		R
4	PI_Velocity_Error_Sum	no	-2147483648	2147483647	0		R

Table 43: Entry Description (2042_h)



4.1.8 Object 2043_h: Position Mode Settings

Object Description			
Index	Name	Object Type	Data Type
2043 _h	Position Mode Settings	Variable	Record

Table 44: Object Description (2043_h)

Entry Description							
Sub-index	Name	PDO Mapping	Min	Max	Default	Unit	Access
1	P_Parameter	no	0	65535	0		RW
2	PID_Position_Error	no	-2147483648	2147483647	0		R

Table 45: Entry Description (2043_h)

4.1.9 Object 2050_h: Motor Type

With this object the motor type connected to the module can be set. The following settings are possible:

- Mode 0: no motor
- Mode 1: single phase DC motor
- Mode 3: three phase BLDC motor

Object Description			
Index	Name	Object Type	Data Type
2050 _h	Limits	Variable	UNSIGNED8

Table 46: Object Description (2050_h)

Entry Description				
Sub-index	Access	PDO Mapping	Value Range	Default Value
0	rw	no	0...3	0

Table 47: Entry Description (2050_h)

4.1.10 Object 2055_h: Commutation Mode

Select a commutation mode that fits best to your motor’s sensors.



Commutation Modes	
0	FOC — disabled
1	FOC — open loop
2	FOC — digital hall
3	FOC — ABN encoder

Table 48: Commutation Modes

Object Description			
Index	Name	Object Type	Data Type
2055 _h	Commutation Mode	Variable	UNSIGNED8

Table 49: Object Description (2055_h)

Entry Description							
Sub-index	Name	PDO Mapping	Min	Max	Default	Unit	Access
0	Commutation Mode	no	0	1	3		RW

Table 50: Entry Description (2055_h)

4.1.11 Object 2056_h: Motor Pole Pairs

Set this object to the number of pole pairs your motor is equipped with.

Object Description			
Index	Name	Object Type	Data Type
2056 _h	Motor Pole Pairs	Variable	UNSIGNED8

Table 51: Object Description (2056_h)

Entry Description							
Sub-index	Name	PDO Mapping	Min	Max	Default	Unit	Access
0	Motor Pole Pairs	no	1	12	255		RW

Table 52: Entry Description (2056_h)

4.1.12 Object 2057_h: Motor Shaft Direction

Using this object the motor shaft direction can be reversed. Set it to 0 (default value) for normal shaft direction or 1 for reversed shaft direction.

Object Description			
Index	Name	Object Type	Data Type
2057 _h	Motor Shaft Direction	Variable	UNSIGNED8

Table 53: Object Description (2057_h)

Entry Description							
Sub-index	Name	PDO Mapping	Min	Max	Default	Unit	Access
0	Motor Shaft Direction	no	0	1	0		RW

Table 54: Entry Description (2057_h)

4.1.13 Object 2058_h: Position Scaler

Using this object all position values can be scaled. It defines the number of steps per mechanical rotation. With its default value of 65536, a move of 65536 steps leads to one mechanical rotation.

Object Description			
Index	Name	Object Type	Data Type
2058 _h	Position Scaler	Variable	SIGNED32

Table 55: Object Description (2058_h)

Entry Description							
Sub-index	Name	PDO Mapping	Min	Max	Default	Unit	Access
0	Position Scaler	no	-2147483648	2147483647	65536		RW

Table 56: Entry Description (2058_h)

4.1.14 Object 2060_h: ADC Configuration

Using this object the ADC offsets for the coil current measurement can be configured. This is necessary for each new motor type.



Object Description			
Index	Name	Object Type	Data Type
2060 _h	ADC Configuration	Variable	Record

Table 57: Object Description (2060_h)

Entry Description							
Sub-index	Name	PDO Mapping	Min	Max	Default	Unit	Access
1	ADC_I0_Raw	no	0	65535	0		RO
2	ADC_I1_Raw	no	0	65535	0		RO
3	ADC_I0_Offset	no	0	65535	33500		RW
4	ADC_I1_Offset	no	0	65535	33500		RW
5	ADC_I0	no	-32768	32767	0		RO
6	ADC_I1	no	-32768	32767	0		RO
7	ADC_I2	no	-32768	32767	0		RO

Table 58: Entry Description (2060_h)

4.1.15 Object 2070_h: Hall Sensor Settings

This object sets various parameters of the hall sensors. If the motor is equipped with hall sensors then set the necessary parameters here.

Object Description			
Index	Name	Object Type	Data Type
2070 _h	Hall Sensor Settings	Variable	Record

Table 59: Object Description (2070_h)

Entry Description							
Sub-index	Name	PDO Mapping	Min	Max	Default	Unit	Access
1	Hall Polarity	no	0	1	0		RW
2	Hall Direction	no	0	1	0		RW
3	Hall Interpolation	no	0	1	1		RW
4	Hall PHI_E offset	no	-32768	32767	0		RW

Table 60: Entry Description (2070_h)



4.1.16 Object 2080_h: ABN Encoder Settings

Using this object all necessary encoder parameters can be set. Check and set these parameters if your motor is equipped with an encoder. It is then also possible to choose between different encoder initialization modes.

Encoder Initialization Modes	
0	Estimate offset
1	Use offset
2	Use hall

Table 61: Encoder Initialization Modes

Object Description			
Index	Name	Object Type	Data Type
2080 _h	ABN Encoder Settings	Variable	Record

Table 62: Object Description (2080_h)

Entry Description							
Sub-index	Name	PDO Mapping	Min	Max	Default	Unit	Access
1	Encoder Direction	no	0	1	0		RW
2	Encoder Steps	no	0	65535	8192		RW
3	Encoder Init Mode	no	0	2	0		RW

Table 63: Entry Description (2080_h)

4.1.17 Object 2101_h: Motor Status Flags

This object provides motor status and error flags. This can be a combination of the bits described in table 64.

Motor Status Flags		
Bit	Name	Meaning
0	Overcurrent	Too high current detected.
1	Undervoltage	Supply voltage too low.
2	Overvoltage	Supply voltage too high.
3	Overtemperature	Maximum driver temperature exceeded.
4	Motor halted	Motor stopped.



Bit	Name	Meaning
5	Hall error	Hall sensor error.
6	Driver error	Motor driver error.
7	Init error	Motor initialization error.
8	Stop mode	Motor in stop mode.
9	Velocity mode	Motor operating in velocity mode.
10	Position mode	Motor operating in position mode.
11	Torque mode	Motor operating in torque mode.
12	Emergency stop	Emergency stop active.
14	Position end	Target position reached.
15	Module initialized	Module initialization complete.
17	IIT exceeded	IIT limit exceeded.
18	Brake active	Brake output active.

Table 64: Motor Status Flags (2101_h)

Object Description			
Index	Name	Object Type	Data Type
2101 _h	Device State	Variable	UNSIGNED32

Table 65: Object Description (2101_h)

Entry Description				
Sub-index	Access	PDO Mapping	Value Range	Default Value
0	ro	no	0...3FFFF _h	0

Table 66: Entry Description (2101_h)

4.1.18 Object 2102_h: Open Loop Commutation Angle

This object shows the open loop commutation angle. It is mainly used by the Trinamic motor tuning tools.

Object Description			
Index	Name	Object Type	Data Type
2102 _h	Open Loop Commutation Angle	Variable	SIGNED16

Table 67: Object Description (2102_h)



Entry Description							
Sub-index	Name	PDO Mapping	Min	Max	Default	Unit	Access
0	Open Loop Commutation Angle	no	-32768	32767	0		RO

Table 68: Entry Description (2102_h)

4.1.19 Object 2103_h: Encoder Commutation Angle

This object shows the encoder commutation angle. It is mainly used by the Trinamic motor tuning tools.

Object Description			
Index	Name	Object Type	Data Type
2103 _h	Encoder Commutation Angle	Variable	SIGNED16

Table 69: Object Description (2103_h)

Entry Description							
Sub-index	Name	PDO Mapping	Min	Max	Default	Unit	Access
0	Encoder Commutation Angle	no	-32768	32767	0		RO

Table 70: Entry Description (2103_h)

4.1.20 Object 2104_h: Hall Commutation Angle

This object shows the hall sensor commutation angle. It is mainly used by the Trinamic motor tuning tools.

Object Description			
Index	Name	Object Type	Data Type
2104 _h	Hall Commutation Angle	Variable	SIGNED16

Table 71: Object Description (2104_h)

Entry Description							
Sub-index	Name	PDO Mapping	Min	Max	Default	Unit	Access
0	Hall Commutation Angle	no	-32768	32767	0		RO

Table 72: Entry Description (2104_h)



4.1.21 Object 2140_h: Home Offset Display

This object shows the home offset. The value is given in encoder or hall increments.

Object Description			
Index	Name	Object Type	Data Type
2140 _h	Home Offset Display	Variable	SIGNED32

Table 73: Object Description (2140_h)

Entry Description							
Sub-index	Name	PDO Mapping	Min	Max	Default	Unit	Access
0	Home Offset Display	no	-2147483648	2147483647	0		R

Table 74: Entry Description (2140_h)

4.1.22 Object 2702_h: Digital Inputs

Bit0: Left limit switch status
 Bit1: Right limit switch status

Object Description			
Index	Name	Object Type	Data Type
2702 _h	Digital Inputs	Variable	UNSIGNED32

Table 75: Object Description (2702_h)

Entry Description							
Sub-index	Name	PDO Mapping	Min	Max	Default	Unit	Access
0	Digital Inputs	no	0	3	0		R

Table 76: Entry Description (2702_h)

4.1.23 Object 2703_h: Digital Outputs

With this object the digital outputs (general purpose outputs) can be set. Bits 23...16 of sub index 1 switch the outputs of the module. Bits 23...16 of sub index 2 determine which outputs can be switched. The number of available digital outputs depends on the module type.



Bit Definitions	
Bit	Description
16	GPO0
17	GPO1
18	GPO2

Table 77: Bit Definitions (2703_h)

Object Description			
Index	Name	Object Type	Data Type
2703 _h	Device Digital Outputs	Variable	ARRAY

Table 78: Object Description (2703_h)

Entry Description					
Sub-index	Description	Access	PDO Mapping	Value Range	Default Value
1	Physical outputs	rw	yes	UNSIGNED32	0
2	Output mask	rw	yes	UNSIGNED32	0

Table 79: Entry Description (2703_h)

4.1.24 Object 270E_h: Analog Inputs

Object Description			
Index	Name	Object Type	Data Type
270E _h	Analog Inputs	Variable	Record

Table 80: Object Description (270E_h)



Entry Description							
Sub-index	Name	PDO Mapping	Min	Max	Default	Unit	Access
1	ADC_IN_0	no	0	4095	0		R
2	ADC_IN_1	no	0	4095	0		R
3	ADC_phase_A	no	0	4095	0		R
4	ADC_phase_B	no	0	4095	0		R
5	ADC_phase_C	no	0	4095	0		R
6	ADC_VSupply	no	0	4095	0		R
7	ADC_Temp	no	0	4095	0		R

Table 81: Entry Description (270E_n)



5 Profile Specific Area

The profile segment contains CiA-402 standard motion control objects. These objects control the motion control functions of the TMCM-1617. Since it is not possible to operate the modes in parallel, the user is able to activate the required function by selecting a mode of operation. The control device writes to the modes of operation object in order to select the operation mode. The drive device provides the modes of operation display object to indicate the actual activated operation mode. Controlword, statusword, and set-points are used mode-specific. This implies the responsibility of the control device to avoid inconsistencies and erroneous behavior.

The following operating modes (selectable via object 6060_h, please see 5.1.6) are implemented on the TMCM-1617:

- Profile position mode (pp)
- Profile velocity mode (pv)
- Homing mode (hm)
- Cyclic position mode (csp)
- Cyclic velocity mode (csv)
- Cyclic torque mode (cst)

5.1 Detailed Object Specifications

5.1.1 Object 605A_h: Quick Stop Option Code

This object indicates what action is performed when the quick stop function is executed. The slow down ramp is the deceleration value of the used mode of operation. The following quick stop option codes are supported in the current version of the CANopen firmware:

Value Definition	
Value	Definition
1	Slow down on <i>slow down ramp</i> and transit into <i>switch on disabled</i>
2	Slow down on <i>quick stop ramp</i> and transit into <i>switch on disabled</i>
5	Slow down on <i>slow down ramp</i> and stay in <i>quick stop active</i>)
6	Slow down on <i>quick stop ramp</i> and stay in <i>quick stop active</i>

Table 82: Value Description (605A_h)

Object Description			
Index	Name	Object Type	Data Type
605A _h	Quick stop option code	Variable	SIGNED16

Table 83: Object Description (605A_h)



Entry Description				
Sub-index	Access	PDO Mapping	Value Range	Default Value
0	rw	no	1/2/5/6	2

Table 84: Entry Description (605A_n)

5.1.2 Object 605B_n: Shutdown Option Code

This object indicates what action is performed if there is a transition from *operation enabled* state to *ready to switch on state*. The shutdown option code always has the value 0 as only this is supported.

Value Definition	
Value	Definition
0	Disable drive function (switch off the power stage)

Table 85: Value Description (605B_n)

Object Description			
Index	Name	Object Type	Data Type
605B _n	Shutdown option code	Variable	UNSIGNED16

Table 86: Object Description (605B_n)

Entry Description				
Sub-index	Access	PDO Mapping	Value Range	Default Value
0	rw	no	0	0

Table 87: Entry Description (605B_n)

5.1.3 Object 605C_n: Disable Operation Option Code

This object indicates what action is performed if there is a transition from *operation enabled* state to *switched on state*. The disable operation option code always has the value 1 as only this is supported. The slow down ramp is the deceleration value of the used mode of operation.

Value Definition	
Value	Definition
1	Slow down on slow down ramp

Table 88: Value Description (605C_n)

Object Description			
Index	Name	Object Type	Data Type
605C _h	Disable operation option code	Variable	UNSIGNED16

Table 89: Object Description (605C_h)

Entry Description				
Sub-index	Access	PDO Mapping	Value Range	Default Value
0	rw	no	1	1

Table 90: Entry Description (605C_h)

5.1.4 Object 605D_h: Halt Option Code

This object indicates what action is performed when the halt function is executed. The slow down ramp is the deceleration value of the used mode of operation.

Value Definition	
Value	Definition
1	Slow down on slow down ramp and stay in <i>operation enabled</i>

Table 91: Value Description (605D_h)

Object Description			
Index	Name	Object Type	Data Type
605D _h	Halt option code	Variable	UNSIGNED16

Table 92: Object Description (605D_h)

Entry Description				
Sub-index	Access	PDO Mapping	Value Range	Default Value
0	rw	no	1	1

Table 93: Entry Description (605D_h)

5.1.5 Object 605E_h: Fault Reaction Option Code

This object indicates what action is performed when fault is detected in the power drive system. The slow down ramp is the deceleration value of the used mode of operation. The fault reaction option code always has the value 2 as only this is supported.



Value Definition	
Value	Definition
2	Slow down on quick stop ramp

Table 94: Value Description (605E_h)

Object Description			
Index	Name	Object Type	Data Type
605E _h	Fault reaction option code	Variable	UNSIGNED16

Table 95: Object Description (605E_h)

Entry Description				
Sub-index	Access	PDO Mapping	Value Range	Default Value
0	rw	no	2	2

Table 96: Entry Description (605E_h)

5.1.6 Object 6060_h: Modes of Operation

This object indicates the requested operation mode. Supported operating modes are:

Value Definition	
Value	Mode
0	No mode
1	Profile position mode (pp)
3	Profile velocity mode (pv)
6	Homing mode (hm)
8	Cyclic synchronous position mode (csp)
9	Cyclic synchronous velocity mode (csv)
10	Cyclic synchronous torque mode (cst)

Table 97: Value Description (6060_h)

The motor will not run when the operating mode is set to 0. It will be stopped when the motor is running in one of the supported operating modes and the operating mode is then switched to 0.



Object Description			
Index	Name	Object Type	Data Type
6060 _h	Modes of operation	Variable	SIGNED8

Table 98: Object Description (6060_h)

Entry Description				
Sub-index	Access	PDO Mapping	Value Range	Default Value
0	rw	refer to CiA-402	see table 97	0

Table 99: Entry Description (6060_h)

5.1.7 Object 6061_h: Modes of Operation Display

This object shows the operating mode that is currently set.

Value Definition	
Value	Mode
0	No mode
1	Profile position mode (pp)
3	Profile velocity mode (pv)
6	Homing mode (hm)
8	Cyclic synchronous position mode (csp)
9	Cyclic synchronous velocity mode (csv)
10	Cyclic synchronous torque mode (cst)

Table 100: Value Description (6061_h)

The motor will not run when the operating mode is set to 0. It will be stopped when the motor is running in one of the supported operating modes and the operating mode is then switched to 0.

Object Description			
Index	Name	Object Type	Data Type
6061 _h	Modes of operation display	Variable	SIGNED8

Table 101: Object Description (6061_h)



Entry Description				
Sub-index	Access	PDO Mapping	Value Range	Default Value
0	rw	refer to CiA-402	see table 100	0

Table 102: Entry Description (6061_h)

5.1.8 Object 606A_h: Sensor Selection Code

This object provides the source of the position sensor actual value. It selects whether an encoder is to be used or not.

Value Definition	
Value	Mode
0	Encoder used
-1	No encoder

Table 103: Value Description (606A_h)

Object Description			
Index	Name	Object Type	Data Type
606A _h	Sensor selection code	Variable	SIGNED16

Table 104: Object Description (606A_h)

Entry Description				
Sub-index	Access	PDO Mapping	Value Range	Default Value
0	rw	no	0/-1	-1

Table 105: Entry Description (606A_h)

5.1.9 Object 608F_h: Position Encoder Resolution

This object defines the resolution of the encoder. The position encoder resolution is calculated by the following formula:

$$position\ encoder\ resolution = \frac{encoder\ increments}{motor\ revolutions}$$

All values are dimensionless.



Object Description			
Index	Name	Object Type	Data Type
608F _h	Position Encoder Resolution	Array	UNSIGNED32

Table 106: Object Description (608F_h)

Entry Description					
Sub-index	Description	Access	PDO Mapping	Value Range	Default Value
0	Highest sub-index supported	ro	no	2	2
1	Encoder increments	rw	no	0...2147483647	1
2	Motor revolutions	ro	no	1	1

Table 107: Entry Description (608F_h)

5.1.10 Object 60FD_h: Digital Inputs

This object contains the states of the digital inputs of the module. Starting from bit 0, every bit reflects the state of one digital input. The number of valid bits depends on the number of digital inputs on the module used.

Object Description			
Index	Name	Object Type	Data Type
60FD _h	Digital inputs	Variable	UNSIGNED32

Table 108: Object Description (60FD_h)

Entry Description				
Sub-index	Access	PDO Mapping	Value Range	Default Value
0	rw	mappable	UNSIGNED32	0

Table 109: Entry Description (60FD_h)

5.1.11 Object 6502_h: Supported Drive Modes

This object provides information on the supported drive modes. A bit that is set means that the mode is supported, a bit that is not set means that the mode is not supported by the drive.



Value Definition	
Bit	Mode
0	Profile position mode (pp)
1	Velocity mode (vl)
2	Profile velocity mode (pv)
3	Torque mode (tq)
4	Reserved
5	Homing mode (hm)
6	Interpolated position mode (ip)
7	Cyclic synchronous position mode (csp)
8	Cyclic synchronous velocity mode (csv)
9	Cyclic synchronous torque mode (cst)

Table 110: Value Definition (6502_h)

Object Description			
Index	Name	Object Type	Data Type
6502 _h	Supported drive modes	Variable	UNSIGNED32

Table 111: Object Description (6502_h)

Entry Description				
Sub-index	Access	PDO Mapping	Value Range	Default Value
0	ro	no	UNSIGNED32	Depends on supported modes.

Table 112: Entry Description (6502_h)



6 Profile Position Mode

A target position is applied to the trajectory generator. It is generating a position demand value for the position control loop described in the position control function.

Please refer to object 6060_h (section 5.1.6) for information about how to choose an operation mode. Object 6061_h (section 5.1.7) shows the operation mode that is set.

6.1 Detailed Object Specifications

The following text offers detailed object specifications. For a better understanding, it is necessary to see how the state machine works.

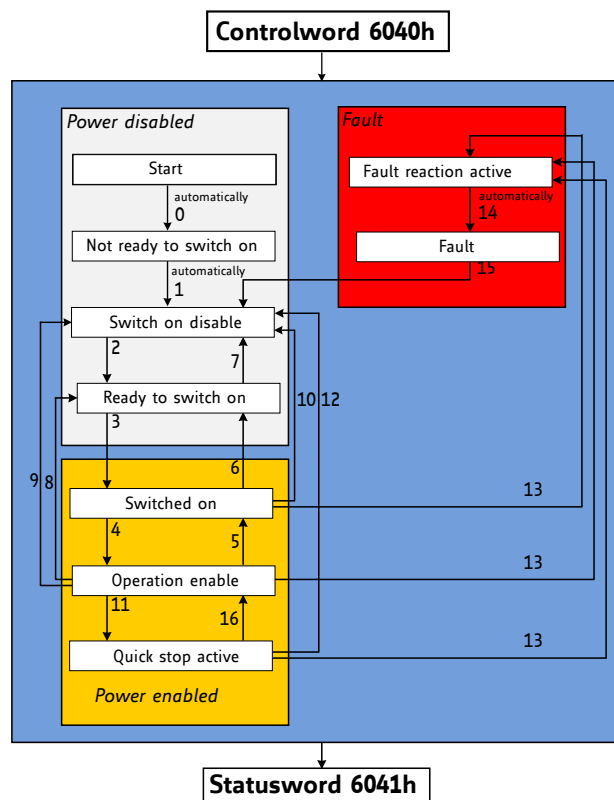

Figure 3: DS402 Finite State Machine

Notes on state transitions:

- Commands directing a change in state are processed completely and the new state achieved before additional state change commands are processed.
- Transitions 0 and 1 occur automatically at drive power-on or reset. Transition 14 occurs automatically, too. All other state changes must be directed by the host.
- Drive function disabled indicates that no current is being supplied to the motor.
- Drive function enabled indicates that current is available for the motor and profile position and profile velocity reference values may be processed.



6.1.1 Object 6040_n: Control Word

This object indicates the received command controlling the power drive system finite state automaton (PDS FSA). The CiA-402 state machine can be controlled using this object. Please refer to figure 3 for detailed information.

Structure of the Control Word											
15	11	10	9	8	7	6	4	3	2	1	0
nu	r	oms	h	fr	oms	eo	qs	ev	so		
MSB											LSB

Legend: nu=not used; r=reserved; oms=operation mode specific; h=halt; fr=fault reset; eo=enable operation; qs=quick stop; ev=enable voltage; so=switch on.

Table 113: Structure of the Control Word in pp Mode

Operation Mode specific Bits in pp Mode		
Bit	Name	Definition
4	New set point	0-to-1: the next positioning will be started.
5	Change immediately	Not supported.
6	Absolute / relative	0: New position is absolute. 1: New position is relative.
9	Change set point	Not supported.

Table 114: Operation Mode specific Bits in pp Mode

Command Coding						
Command	Bits of Control Word					Transitions
	Bit 7	Bit 3	Bit 2	Bit 1	Bit 0	
Shutdown	0	x	1	1	0	2,6,8
Switch on	0	0	1	1	1	3
Switch on & enable operation	0	1	1	1	1	3, 4
Disable voltage	0	x	x	0	x	7,9,10,12
Quick stop	0	x	0	1	x	7,10,11
Disable operation	0	0	1	1	1	5
Enable operation	0	1	1	1	1	4, 16
Fault reset	0-to-1	x	x	x	x	15

Table 115: Command Coding



Object Description			
Index	Name	Object Type	Data Type
6040 _h	Controlword	Variable	UNSIGNED16

Table 116: Object Description (6040_h in pp Mode)

Entry Description				
Sub-index	Access	PDO Mapping	Value Range	Default Value
0	rw	see CiA402-3	See command coding above.	

Table 117: Entry Description (6040_h in pp Mode)

6.1.2 Object 6041_h: Status Word

This object provides the status of the PDS FSA. It reflects the status of the CiA-402 state machine. Please refer to figure 3 for detailed information. The object is structured as defined below. For more information about the coding please refer to the CANopen Drives and motion control device profile, part 2.

Structure of the Status Word															
15	14	13	12	11	10	9	8	7	6	5	4	3	2	1	0
dir	mot	oms	ila	tr	rm	ms	w	sod	qs	ve	f	oe	so	rtso	
MSB														LSB	

Legend: nu=not used; r=reserved; oms=operation mode specific; h=halt; fr=fault reset; oe=operation enable; qs=quick stop; ve=voltage enable; so=switch on.

Table 118: Structure of the Staus Word in pp Mode

Trinamic Specific Bits		
Bit	Name	Definition
14	Motor activity	0: Motor stands still. 1: Motor rotates.
15	Direction of rotation	This bit shows the direction of rotation.

Table 119: Trinamic Specific Bits



Operation Mode specific Bits in pp Mode		
Bit	Name	Definition
10	Target reached	Set when the motor is within the position window.
12	Set point acknowledged	0: Set point processed. 1: Set point still in process.
13	Following error	Not supported.

Table 120: Operation Mode specific Bits in pp Mode

State Coding	
Status word	FSA state
xxxx xxxx x0xx 0000 _h	Not ready to switch on
xxxx xxxx x1xx 0000 _h	Switch on disabled
xxxx xxxx x01x 0001 _h	Ready to switch on
xxxx xxxx x01x 0011 _h	Switched on
xxxx xxxx x01x 0111 _h	Operation enabled
xxxx xxxx x00x 0111 _h	Quick stop active
xxxx xxxx x0xx 1111 _h	Fault reaction active
xxxx xxxx x0xx 1000 _h	Fault

Table 121: State Coding

Object Description			
Index	Name	Object Type	Data Type
6041 _h	Controlword	Variable	UNSIGNED16

Table 122: Object Description (6041_h in pp Mode)

Entry Description				
Sub-index	Access	PDO Mapping	Value Range	Default Value
0	rw	see CiA402-3	See state coding above.	

Table 123: Entry Description (6041_h in pp Mode)

6.1.3 Object 6062_h: Position Demand Value

This object provides the demanded position value. The value is given in microsteps. Object 6062_h indicates the actual position that the motor should have. It is not to be confused with objects 6063_h and 6064_h.



Object Description			
Index	Name	Object Type	Data Type
6062 _h	Position Demand Value	Variable	SIGNED32

Table 124: Object Description (6062_h)

Entry Description				
Sub-index	Access	PDO Mapping	Value Range	Default Value
0	ro	Refer to CiA402-3	SIGNED32	no

Table 125: Entry Description (6062_h)

6.1.4 Object 6063_h: Position Actual Internal Value

This object provides the demanded position value. The value is given in microsteps. It is the same as object 6062_h.

Object Description			
Index	Name	Object Type	Data Type
6063 _h	Position Actual Internal Value	Variable	SIGNED32

Table 126: Object Description (6063_h)

Entry Description				
Sub-index	Access	PDO Mapping	Value Range	Default Value
0	ro	Refer to CiA402-3	SIGNED32	no

Table 127: Entry Description (6063_h)

6.1.5 Object 6064_h: Position Actual Value

This object provides the actual value of the position measurement device. It always contains the same value as object 6063_h.

Object Description			
Index	Name	Object Type	Data Type
6064 _h	Position Actual Value	Variable	SIGNED32

Table 128: Object Description (6064_h)



Entry Description				
Sub-index	Access	PDO Mapping	Value Range	Default Value
0	ro	Refer to CiA402-3	SIGNED32	no

Table 129: Entry Description (6064_h)

6.1.6 Object 6065_h: Following Error Window

This object indicates the configured range of tolerated position values symmetrically to the position demand value. If the position actual value is out of the following error window, a following error occurs. A following error may occur when a drive is blocked, unreachable profile velocity occurs, or at wrong closed-loop coefficients. The value shall be given in microsteps.

When the difference between motor position (object 6062_h) and encoder position (object 6063_h or 6064_h) is greater than the value set here, the motor will be stopped and an emergency message will be sent. Setting this object to zero will turn off this feature completely.

Note Setting this object to a too low value will lead to false alarms.

Object Description			
Index	Name	Object Type	Data Type
6065 _h	Following Error Window	Variable	UNSIGNED32

Table 130: Object Description (6065_h)

Entry Description				
Sub-index	Access	PDO Mapping	Value Range	Default Value
0	rw	no	0...2147483647	0

Table 131: Entry Description (6065_h)

6.1.7 Object 6067_h: Position Window

This object indicates the configured symmetrical range of accepted positions relative to the target position. If the actual value of the position encoder is within the position window, this target position is regarded as having been reached. The value is given in increments. If the value of the position window is FFFFFFFF_h, the position window control is switched off. If this object is set to zero, the target reached event will be signaled when the demand position (6062_h) has reached the target position (6064_h). When the position window is set to a value greater than zero, the target reached event will be signaled when the actual encoder position value (6064_h) is within $(target_position - position_window)$ and $(target_position + position_window)$.



Object Description			
Index	Name	Object Type	Data Type
6067 _h	Position Window	Variable	UNSIGNED32

Table 132: Object Description (6067_h)

Entry Description				
Sub-index	Access	PDO Mapping	Value Range	Default Value
0	rw	no	UNSIGNED32	FFFFFFF _h

Table 133: Entry Description (6067_h)

6.1.8 Object 6068_h: Position Window Time

This object indicates the configured time, during which the actual position within the position window is measured. The value is given in ms. If this object is set to a value greater than zero and also the position window (6067_h) is set to a value greater than zero the target reached event will not be signaled until the actual position (6064_h) is at least as many milliseconds within the position window as defined by this object.

Object Description			
Index	Name	Object Type	Data Type
6068 _h	Position Window Time	Variable	UNSIGNED16

Table 134: Object Description (6068_h)

Entry Description				
Sub-index	Access	PDO Mapping	Value Range	Default Value
0	rw	no	UNSIGNED16	0

Table 135: Entry Description (6068_h)

6.1.9 Object 606C_h: Velocity Actual Value

This object shows the actual velocity value of the motor. The value is given in units of pps.

Object Description			
Index	Name	Object Type	Data Type
606C _h	Velocity Actual Value	Variable	SIGNED32

Table 136: Object Description (606C_h)

Entry Description				
Sub-index	Access	PDO Mapping	Value Range	Default Value
0	ro	Refer to CiA402-3	SIGNED32	no

Table 137: Entry Description (606C_h)

6.1.10 Object 607A_h: Target Position

The target position is the position that the drive should move to in profile position mode using the current settings of motion control parameters (such as velocity, acceleration, deceleration, motion profile type etc.). The value of this object is interpreted as absolute or relative depending on the abs/rel flag in the controlword. It is given in microsteps.

Object Description			
Index	Name	Object Type	Data Type
607A _h	Target Position	Variable	SIGNED32

Table 138: Object Description (607A_h in pp Mode)

Entry Description				
Sub-index	Access	PDO Mapping	Value Range	Default Value
0	rw	Refer to CiA402-3	SIGNED32	0

Table 139: Entry Description (607A_h in pp Mode)

6.1.11 Object 607D_h: Software Position Limit

This object indicates the configured maximal and minimal software position limits. These parameters define the absolute position limits for the position demand value and the position actual value. Every new target position is checked against these limits. The limit positions are always relative to the machine home position. Before being compared with the target position, they are corrected internally by the home offset as follows:

$$\text{Corrected_min_position_limit} = \text{min_position_limit} - \text{home_offset}$$

$$\text{Corrected_max_position_limit} = \text{max_position_limit} - \text{home_offset}$$

Object Description			
Index	Name	Object Type	Data Type
607D _h	Software Position Limit	Array	SIGNED32

Table 140: Object Description (607D_h)

Entry Description					
Sub-index	Description	Access	PDO Mapping	Value Range	Default Value
1	Minimum Position Limit	rw	no	SIGNED32	-2147483648
2	Maximum Position Limit	rw	no	SIGNED32	2147483647

Table 141: Entry Description (607D_h)

6.1.12 Object 6081_h: Profile Velocity

This object indicates the configured velocity normally attained at the end of the acceleration ramp during a profiled motion and is valid for both directions of motion. The profile velocity is the maximum velocity used when driving to a new position. It is given in units of pps².

Object Description			
Index	Name	Object Type	Data Type
6081 _h	Profile Velocity	Variable	UNSIGNED32

Table 142: Object Description (6081_h)

Entry Description				
Sub-index	Access	PDO Mapping	Value Range	Default Value
0	rw	no	UNSIGNED32	0

Table 143: Entry Description (6081_h)

6.1.13 Object 6083_h: Profile Acceleration

This object indicates the configured acceleration. Object 6083_h sets the maximum acceleration to be used in profile position and profile velocity mode.

This value is given using pps² units.

In profile velocity mode, this object also sets the deceleration to be used (the deceleration ramp is always the same as the acceleration ramp in pv mode).

Object Description			
Index	Name	Object Type	Data Type
6083 _h	Profile Acceleration	Variable	UNSIGNED32

Table 144: Object Description (6083_h)

Entry Description				
Sub-index	Access	PDO Mapping	Value Range	Default Value
0	rw	no	UNSIGNED32	0

Table 145: Entry Description (6083_h)

6.1.14 Object 6084_h: Profile Deceleration

This object indicates the configured deceleration. Object 6084_h sets the maximum deceleration to be used in profile positioning mode.

This value is given in units of pps².

Object Description			
Index	Name	Object Type	Data Type
6084 _h	Profile Deceleration	Variable	UNSIGNED32

Table 146: Object Description (6084_h)

Entry Description				
Sub-index	Access	PDO Mapping	Value Range	Default Value
0	rw	no	UNSIGNED32	0

Table 147: Entry Description (6084_h)

6.1.15 Object 6085_h: Quick Stop Deceleration

This object indicates the configured deceleration used to stop the motor when the quick stop function is activated and the quick stop code object 605A_h is set to 2 (or 6). The value is given in the same unit as profile acceleration object 6083_h.

Object Description			
Index	Name	Object Type	Data Type
6085 _h	Quick stop deceleration	Variable	UNSIGNED32

Table 148: Object Description (6085_h)

Entry Description				
Sub-index	Access	PDO Mapping	Value Range	Default Value
0	rw	no	UNSIGNED32	51200

Table 149: Entry Description (6085_h)

6.1.16 Object 60F2_h: Positioning Option Code

This object indicates the positioning behaviour in profile position mode. Only bits 0 and 1 (relative option) are supported.



Bit Definitions		
Bit 1	Bit 0	Definition
0	0	Positioning moves shall be performed relative to the preceding (internal absolute) target position.
0	1	Positioning moves shall be performed relative to the actual position demand value (object 6063 _h).
1	0	Positioning moves shall be performed relative to the position actual value (object 6064 _h).
1	1	reserved

Table 150: Bit Definitions of Object 60F2_h

Object Description			
Index	Name	Object Type	Data Type
60F2 _h	Positioning option code	Variable	UNSIGNED16

Table 151: Object Description (60F2_h)

Entry Description				
Sub-index	Access	PDO Mapping	Value Range	Default Value
0	rw	no	UNSIGNED16	0

Table 152: Entry Description (60F2_h)

6.2 How to move a Motor in pp Mode

Here is a little example that shows how to get a motor running in pp mode. In this little example we assume that the module has been reset (and then switched to pre-operational or operational) by NMT commands before. Please note that the values are decimal.

- If you do not have any limit switches connected, first disable the limit switch inputs by writing 3 to object 2005_h.
- Select pp mode by writing 1 to object 6060_h.
- Write 6 to object 6040_h to switch to READY_TO_SWITCH_ON state.
- Write 7 to object 6040_h to switch to SWITCHED_ON state.
- Write 15 to object 6040_h to switch to OPERATION_ENABLED state.
- Write the desired target position (e.g. 500000) to object 607A_h.
- Mark the new target position as active by writing 31 to object 6040_h. The motor starts moving now.
- Reset the activation by writing 15 to object 6040_h (this can be done while the motor is still moving).



7 Profile Velocity Mode

The profile velocity mode is used to control the velocity of the drive without a special regard of the position. It contains limit functions and trajectory generation.

The profile velocity mode covers the following sub-functions:

- Demand value input via trajectory generator.
- Monitoring of the profile velocity using a window-function.
- Monitoring of velocity actual value using a threshold.

The operation of the reference value generator and its input parameters include:

- Profile velocity
- Profile acceleration
- Profile deceleration
- Emergency stop
- Motion profile type

7.1 Detailed Object Specifications

7.1.1 Object 6040_n: Control Word

This object indicates the received command controlling the power drive system finite state automaton (PDS FSA). The CiA-402 state machine can be controlled using this object. Please refer to figure 3 for detailed information.

In pv mode the control word does not contain any operation mode specific bits.

Structure of the Control Word											
15	11	10	9	8	7	6	4	3	2	1	0
nu	r	r	h	fr	r	eo	qs	ev	so		
MSB						LSB					

Legend: nu=not used; r=reserved; h=halt; fr=fault reset; eo=enable operation; qs=quick stop; ev=enable voltage; so=switch on.

Table 153: Structure of the Control Word in pv Mode



Command Coding						
Command	Bits of Control Word					Transitions
	Bit 7	Bit 3	Bit 2	Bit 1	Bit 0	
Shutdown	0	x	1	1	0	2,6,8
Switch on	0	0	1	1	1	3
Switch on & enable operation	0	1	1	1	1	3, 4
Disable voltage	0	x	x	0	x	7,9,10,12
Quick stop	0	x	0	1	x	7,10,11
Disable operation	0	0	1	1	1	5
Enable operation	0	1	1	1	1	4, 16
Fault reset	0-to-1	x	x	x	x	15

Table 154: Command Coding

Object Description			
Index	Name	Object Type	Data Type
6040 _h	Controlword	Variable	UNSIGNED16

Table 155: Object Description (6040_h in pv Mode)

Entry Description				
Sub-index	Access	PDO Mapping	Value Range	Default Value
0	rw	see CiA402-3	See command coding above.	

Table 156: Entry Description (6040_h in pv Mode)

7.1.2 Object 6041_h: Status Word

This object provides the status of the PDS FSA. It reflects the status of the CiA-402 state machine. Please refer to figure 3 for detailed information. The object is structured as defined below. For more information about the coding please refer to the CANopen Drives and motion control device profile, part 2.

Structure of the Status Word															
15	14	13	12	11	10	9	8	7	6	5	4	3	2	1	0
dir	mot	oms	ila	tr	rm	ms	w	sod	qs	ve	f	oe	so	rtso	
MSB														LSB	

Legend: nu=not used; r=reserved; oms=operation mode specific; h=halt; fr=fault reset; oe=operation enable; qs=quick stop; ve=voltage enable; so=switch on.

Table 157: Structure of the Status Word in pv Mode



Trinamic Specific Bits		
Bit	Name	Definition
14	Motor activity	0: Motor stands still. 1: Motor rotates.
15	Direction of rotation	This bit shows the direction of rotation.

Table 158: Trinamic Specific Bits

Operation Mode specific Bits in pv Mode		
Bit	Name	Definition
10	Target reached	Indicates that the target speed has been reached.
12	Speed	Not supported.
13	Max. slippage error	Not supported.

Table 159: Operation Mode specific Bits in pv Mode

State Coding	
Status word	FSA state
xxxx xxxx x0xx 0000 _h	Not ready to switch on
xxxx xxxx x1xx 0000 _h	Switch on disabled
xxxx xxxx x01x 0001 _h	Ready to switch on
xxxx xxxx x01x 0011 _h	Switched on
xxxx xxxx x01x 0111 _h	Operation enabled
xxxx xxxx x00x 0111 _h	Quick stop active
xxxx xxxx x0xx 1111 _h	Fault reaction active
xxxx xxxx x0xx 1000 _h	Fault

Table 160: State Coding

Object Description			
Index	Name	Object Type	Data Type
6041 _h	Controlword	Variable	UNSIGNED16

Table 161: Object Description (6041_h in pv Mode)



Entry Description				
Sub-index	Access	PDO Mapping	Value Range	Default Value
0	rw	see CiA402-3	See state coding above	

Table 162: Entry Description (6041_h in pv Mode)

7.1.3 Object 6062_h: Position Demand Value

This object provides the demanded position value. The value is given in microsteps. Object 6062_h indicates the actual position that the motor should have. It is not to be confused with objects 6063_h and 6064_h.

Object Description			
Index	Name	Object Type	Data Type
6062 _h	Position Demand Value	Variable	SIGNED32

Table 163: Object Description (6062_h)

Entry Description				
Sub-index	Access	PDO Mapping	Value Range	Default Value
0	ro	Refer to CiA402-3	SIGNED32	no

Table 164: Entry Description (6062_h)

7.1.4 Object 6063_h: Position Actual Internal Value

This object provides the demanded position value. The value is given in microsteps. It is the same as object 6062_h.

Object Description			
Index	Name	Object Type	Data Type
6063 _h	Position Actual Internal Value	Variable	SIGNED32

Table 165: Object Description (6063_h)

Entry Description				
Sub-index	Access	PDO Mapping	Value Range	Default Value
0	ro	Refer to CiA402-3	SIGNED32	no

Table 166: Entry Description (6063_h)

7.1.5 Object 6064_h: Position Actual Value

This object provides the actual value of the position measurement device. It always contains the same value as object 6063_h.



Object Description			
Index	Name	Object Type	Data Type
6064 _h	Position Actual Value	Variable	SIGNED32

Table 167: Object Description (6064_h)

Entry Description				
Sub-index	Access	PDO Mapping	Value Range	Default Value
0	ro	Refer to CiA402-3	SIGNED32	no

Table 168: Entry Description (6064_h)

7.1.6 Object 6065_h: Following Error Window

This object indicates the configured range of tolerated position values symmetrically to the position demand value. If the position actual value is out of the following error window, a following error occurs. A following error may occur when a drive is blocked, unreachable profile velocity occurs, or at wrong closed-loop coefficients. The value shall be given in microsteps.

When the difference between motor position (object 6062_h) and encoder position (object 6063_h or 6064_h) is greater than the value set here, the motor will be stopped and an emergency message will be sent. Setting this object to zero will turn off this feature completely.

Note Setting this object to a too low value will lead to false alarms.

Object Description			
Index	Name	Object Type	Data Type
6065 _h	Following Error Window	Variable	UNSIGNED32

Table 169: Object Description (6065_h)

Entry Description				
Sub-index	Access	PDO Mapping	Value Range	Default Value
0	rw	no	0...2147483647	0

Table 170: Entry Description (6065_h)

7.1.7 Object 606C_h: Velocity Actual Value

This object shows the actual velocity value of the motor. The value is given in units of pps.



Object Description			
Index	Name	Object Type	Data Type
606C _h	Velocity Actual Value	Variable	SIGNED32

Table 171: Object Description (606C_h)

Entry Description				
Sub-index	Access	PDO Mapping	Value Range	Default Value
0	ro	Refer to CiA402-3	SIGNED32	no

Table 172: Entry Description (606C_h)

7.1.8 Object 607D_h: Software Position Limit

This object indicates the configured maximal and minimal software position limits. These parameters define the absolute position limits for the position demand value and the position actual value. Every new target position is checked against these limits. The limit positions are always relative to the machine home position. Before being compared with the target position, they are corrected internally by the home offset as follows:

$$\text{Corrected_min_position_limit} = \text{min_position_limit} - \text{home_offset}$$

$$\text{Corrected_max_position_limit} = \text{max_position_limit} - \text{home_offset}$$

Object Description			
Index	Name	Object Type	Data Type
607D _h	Software Position Limit	Array	SIGNED32

Table 173: Object Description (607D_h)

Entry Description					
Sub-index	Description	Access	PDO Mapping	Value Range	Default Value
1	Minimum Position Limit	rw	no	SIGNED32	-2147483648
2	Maximum Position Limit	rw	no	SIGNED32	2147483647

Table 174: Entry Description (607D_h)

7.1.9 Object 6083_h: Profile Acceleration

This object indicates the configured acceleration. Object 6083_h sets the maximum acceleration to be used in profile position and profile velocity mode.

This value is given using pps² units.



In profile velocity mode, this object also sets the deceleration to be used (the deceleration ramp is always the same as the acceleration ramp in pv mode).

Object Description			
Index	Name	Object Type	Data Type
6083 _h	Profile Acceleration	Variable	UNSIGNED32

Table 175: Object Description (6083_h)

Entry Description				
Sub-index	Access	PDO Mapping	Value Range	Default Value
0	rw	no	UNSIGNED32	0

Table 176: Entry Description (6083_h)

7.1.10 Object 6085_h: Quick Stop Deceleration

This object indicates the configured deceleration used to stop the motor when the quick stop function is activated and the quick stop code object 605A_h is set to 2 (or 6). The value is given in the same unit as profile acceleration object 6083_h.

Object Description			
Index	Name	Object Type	Data Type
6085 _h	Quick stop deceleration	Variable	UNSIGNED32

Table 177: Object Description (6085_h)

Entry Description				
Sub-index	Access	PDO Mapping	Value Range	Default Value
0	rw	no	UNSIGNED32	51200

Table 178: Entry Description (6085_h)

7.1.11 Object 60FF_h: Target Velocity

This object indicates the configured target velocity and is used as input for the trajectory generator. Object 60FF_h sets the target velocity when using profile velocity mode. The drive then accelerates or decelerates to that velocity using the acceleration and deceleration set by objects 6083_h and 6084_h. The values are given in pps units.

Object Description			
Index	Name	Object Type	Data Type
60FF _h	Target Velocity	Variable	SIGNED32

Table 179: Object Description (60FF_h)



Entry Description				
Sub-index	Access	PDO Mapping	Value Range	Default Value
0	rw	see CiA402-3	SIGNED32	0

Table 180: Entry Description (60FF_h)

7.2 How to move a Motor in pv Mode

Here is a little example that shows how to get a motor running in pv mode. In this little example we assume that the module has been reset (and then switched to pre-operational or operational) by NMT commands before.

- If you do not have any limit switches connected, first disable the limit switch inputs by writing 3 to object 2005_h.
- Select pv mode by writing 3 to object 6060_h.
- Write 6 to object 6040_h to switch to READY_TO_SWITCH_ON state.
- Write 7 to object 6040_h to switch to SWITCHED_ON state.
- Write 15 to object 6040_h to switch to OPERATION_ENABLED state.
- Write the desired target speed (e.g. 100000) to object 60FF_h. The motor now accelerates to that speed.
- Stop the motor by writing 0 to object 60FF_h.



8 Homing Mode

This chapter describes the method by which a drive seeks the home position (reference point). There are various methods of achieving this using limit switches at the ends of travel or a home switch in mid-travel. Some methods also use the index (zero) pulse train from an incremental encoder. The user may specify the speeds, acceleration and the method of homing.

There is no output data except for those bits in the statusword which return the status or result of the homing process and the demand to the position control loops.

There are four sources of the homing signal available: these are positive and negative limit switches, the home switch and the index pulse from an encoder.

Figure 4 shows the defined input objects as well as the output objects. The user can specify the speeds, acceleration and method of homing. The home offset object 607C_h allows displacing the zero in point the coordinate system for the home position.

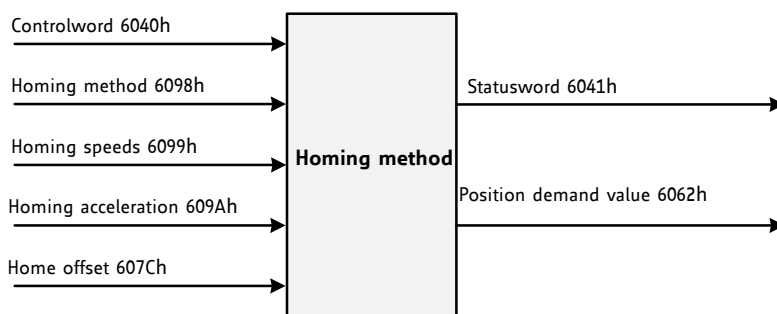

Figure 4: Homing Mode Function

Choosing a homing mode determines the following things:

- The homing signal (positive limit switch, negative limit switch, and home switch).
- The direction of actuation where appropriate.
- The position of the index pulse.

The home position and the zero position are offset by the home offset (see object 607C_h, section 8.2.4).

Depending on the module there are different sources of homing methods available:

- Negative and positive limit switches.
- Home switch.
- Index pulse of an encoder.

For the operation of positioning drives, an exact knowledge of the absolute position is normally required. Since for cost reasons drives often do not have an absolute encoder, a homing operation is necessary.



8.1 Homing Methods

The TMCM-1617 supports a subset of different standard CANopen homing methods. The homing method that is to be used can be chosen via object 6098_h (section 8.2.5).

Supported Homing Methods	
Method	Description
0	No homing (default value for object 6098 _h).
17	Search the left end switch.
18	Search the right end switch.
19	Search the positive edge of the home switch.
21	Search the negative edge of the home switch.
35	The actual position is used as home position. All position values (objects 6062h, 6063h, and 6064h) are set to zero, but the motor will not move.

Table 181: Supported CANopen Homing Methods

When using homing methods that need end switch inputs or home switch inputs please take care of their configuration (object 2005_h, section 4.1.4).

8.1.1 Homing Method 17: Homing on negative Limit Switch

Using this method, the initial direction of movement shall be leftward if the negative limit switch is inactive (here: low). The home position shall at the point where the negative limit switch becomes inactive.

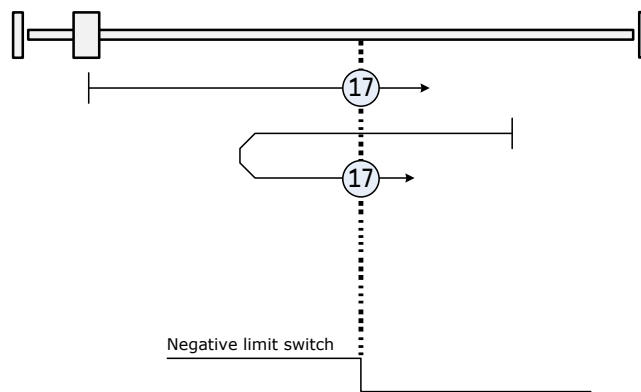

Figure 5: Homing Method 17

8.1.2 Homing Method 18: Homing on positive Limit Switch

Using this method, the initial direction of movement shall be rightward if the positive limit switch is inactive (here: low). The home position shall be at point the where the positive limit switch becomes inactive.



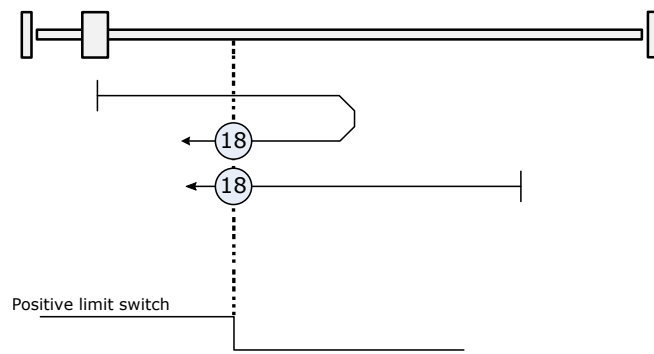

Figure 6: Homing Method 18

8.1.3 Homing Method 19: Homing on positive Home Switch

Using this method, the initial direction of movement shall be dependent on the state of the home switch. The home position shall be at the point where the home switch changes state. If the initial direction of movement leads away from the home switch, the drive shall reverse on encountering the relevant limit switch.

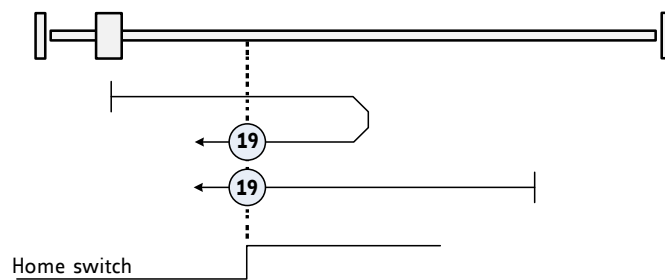

Figure 7: Homing Method 19

8.1.4 Homing Method 21: Homing on negative Home Switch

Using this method, the initial direction of movement shall be dependent on the state of the home switch. The home position shall be at the point where the home switch changes state. If the initial direction of movement leads away from the home switch, the drive shall reverse on encountering the relevant limit switch.

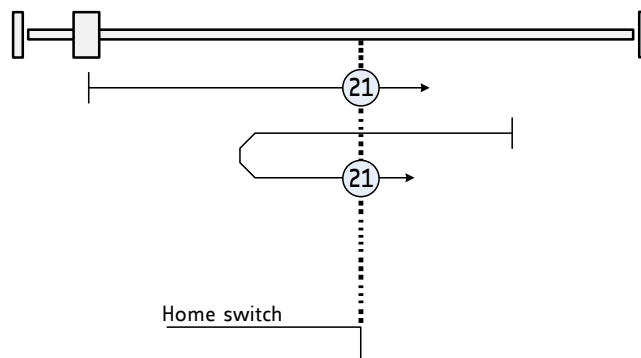

Figure 8: Homing Method 21



8.1.5 Homing Method 35: Current Position as Home Position

In this method, the current position shall be taken to be the home position. This method does not require the drive device to be in operation enabled state.



8.2 Detailed Object Specifications

8.2.1 Object 6040_h: Control Word

This object indicates the received command controlling the power drive system finite state automaton (PDS FSA). The CiA-402 state machine can be controlled using this object. Please refer to figure 3 for detailed information.

Structure of the Control Word											
15	11	10	9	8	7	6	4	3	2	1	0
nu	r	oms	h	fr	oms	eo	qs	ev	so		
MSB						LSB					

Legend: nu=not used; r=reserved; oms=operation mode specific; h=halt; fr=fault reset; eo=enable operation; qs=quick stop; ev=enable voltage; so=switch on.

Table 182: Structure of the Control Word in hm Mode

Operation Mode specific Bits in hm Mode		
Bit	Name	Definition
4	Homing operation start	1: start homing; 0: stop homing
8	Halt	Not supported.

Table 183: Operation Mode specific Bits in hm Mode

Command Coding						
Command	Bits of Control Word					Transitions
	Bit 7	Bit 3	Bit 2	Bit 1	Bit 0	
Shutdown	0	x	1	1	0	2,6,8
Switch on	0	0	1	1	1	3
Switch on & enable operation	0	1	1	1	1	3, 4
Disable voltage	0	x	x	0	x	7,9,10,12
Quick stop	0	x	0	1	x	7,10,11
Disable operation	0	0	1	1	1	5
Enable operation	0	1	1	1	1	4, 16
Fault reset	0-to-1	x	x	x	x	15

Table 184: Command Coding



Object Description			
Index	Name	Object Type	Data Type
6040 _h	Controlword	Variable	UNSIGNED16

Table 185: Object Description (6040_h in hm Mode)

Entry Description				
Sub-index	Access	PDO Mapping	Value Range	Default Value
0	rw	see CiA402-3	See command coding above.	

Table 186: Entry Description (6040_h in hm Mode)

8.2.2 Object 6041_h: Status Word

This object provides the status of the PDS FSA. It reflects the status of the CiA-402 state machine. Please refer to figure 3 for detailed information. The object is structured as defined below. For more information about the coding please refer to the CANopen Drives and motion control device profile, part 2.

Structure of the Status Word															
15	14	13	12	11	10	9	8	7	6	5	4	3	2	1	0
dir	mot	oms	ila	tr	rm	ms	w	sod	qs	ve	f	oe	so	rtso	
MSB														LSB	

Legend: nu=not used; r=reserved; oms=operation mode specific; h=halt; fr=fault reset; oe=operation enable; qs=quick stop; ve=voltage enable; so=switch on.

Table 187: Structure of the Status Word in hm Mode

Trinamic Specific Bits		
Bit	Name	Definition
14	Motor activity	0: Motor stands still. 1: Motor rotates.
15	Direction of rotation	This bit shows the direction of rotation.

Table 188: Trinamic Specific Bits



Operation Mode specific Bits in hm Mode		
Bit	Name	Definition
10	Target reached	Set when the zero position has been found or homing has been stopped by setting controlword bit 4 to zero.
12	Home attained	Set when zero position has been found.
13	Homing error	Not supported.

Table 189: Operation Mode specific Bits in hm Mode

State Coding	
Status word	FSA state
xxxx xxxx x0xx 0000 _h	Not ready to switch on
xxxx xxxx x1xx 0000 _h	Switch on disabled
xxxx xxxx x01x 0001 _h	Ready to switch on
xxxx xxxx x01x 0011 _h	Switched on
xxxx xxxx x01x 0111 _h	Operation enabled
xxxx xxxx x00x 0111 _h	Quick stop active
xxxx xxxx x0xx 1111 _h	Fault reaction active
xxxx xxxx x0xx 1000 _h	Fault

Table 190: State Coding

Object Description			
Index	Name	Object Type	Data Type
6041 _h	Controlword	Variable	UNSIGNED16

Table 191: Object Description (6041_h in hm Mode)

Entry Description				
Sub-index	Access	PDO Mapping	Value Range	Default Value
0	rw	see CiA402-3	See state coding above.	

Table 192: Entry Description (6041_h in hm Mode)

8.2.3 Object 606C_h: Velocity Actual Value

This object shows the actual velocity value of the motor. The value is given in units of pps.



Object Description			
Index	Name	Object Type	Data Type
606C _h	Velocity Actual Value	Variable	SIGNED32

Table 193: Object Description (606C_h)

Entry Description				
Sub-index	Access	PDO Mapping	Value Range	Default Value
0	ro	Refer to CiA402-3	SIGNED32	no

Table 194: Entry Description (606C_h)

8.2.4 Object 607C_h: Home Offset

This object indicates the configured difference between the zero position for the application and the machine home position/home switch (found during homing). While homing, the machine home position is found and once the homing is completed, the zero position is offset from the home position by adding the home offset to the home position. The effect of setting the home position to a non-zero value depends on the selected homing method. The value of this object is given in microsteps. Negative values indicate the opposite direction.

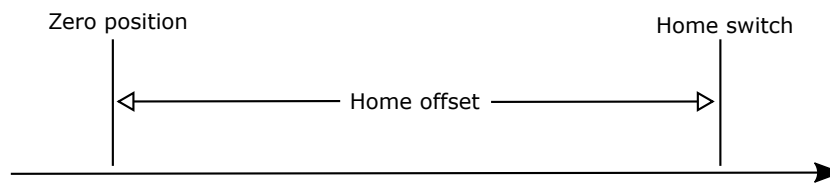

Figure 9: Home Offset

Object Description			
Index	Name	Object Type	Data Type
607C _h	Home offset	Variable	SIGNED32

Table 195: Object Description (607C_h)

Entry Description				
Sub-index	Access	PDO Mapping	Value Range	Default Value
0	rw	no	SIGNED32	0

Table 196: Entry Description (607C_h)



8.2.5 Object 6098_h: Homing Method

The homing method to be used can be selected by writing to this object. Please see table 181 for a list of homing methods supported by the current version of the TMCM-1617 CANopen firmware.

Object Description			
Index	Name	Object Type	Data Type
6098 _h	Homing method	Variable	SIGNED8

Table 197: Object Description (6098_h)

Entry Description				
Sub-index	Access	PDO Mapping	Value Range	Default Value
0	rw	no	SIGNED8	0

Table 198: Entry Description (6098_h)

8.2.6 Object 6099_h: Homing Speeds

This object indicates the configured speeds used during homing procedure. The values are given in pps units. Using object 6099_h a fast and a slow homing speed can be set. In most homing modes, the home switch is searched with the fast speed first. When the home switch has been found, the motor will be decelerated to the slow speed (using the homing acceleration, object 609A_h) to search for the exact switch point. When the switch point has been found the motor will be stopped at that point.

Object Description			
Index	Name	Object Type	Data Type
6099 _h	Homing speeds	Array	UNSIGNED32

Table 199: Object Description (6099_h)

Entry Description					
Sub-index	Description	Access	PDO Mapping	Value Range	Default Value
1	Fast homing speed	rw	no	UNSIGNED32	0
2	Slow homing speed	rw	no	UNSIGNED32	0

Table 200: Entry Description (6099_h)

8.2.7 Object 609A_h: Homing Acceleration

This object indicates the configured acceleration and deceleration to be used during homing operation. This object used pps² units.



Object Description			
Index	Name	Object Type	Data Type
609A _h	Homing acceleration	Variable	UNSIGNED32

Table 201: Object Description (609A_h)

Entry Description				
Sub-index	Access	PDO Mapping	Value Range	Default Value
0	rw	no	UNSIGNED32	0

Table 202: Entry Description (609A_h)

8.3 How to start a Homing in hm Mode

Here is a little example that shows how to home the motor in hm mode. In this little example we assume that the module has been reset (and then switched to pre-operational or operational) by NMT commands before. The home switch must be connected to the home switch input. It can be operated manually.

- Select hm mode by writing 6 to object 6060_h.
- Write 6 to object 6040_h to switch to READY_TO_SWITCH_ON state.
- Write 7 to object 6040_h to switch to SWITCHED_ON state.
- Write 15 to object 6040_h to switch to OPERATION_ENABLED state.
- Select homing method 19 by writing 19 to object 6098_h.
- Set the homing speeds by writing e.g. 50000 to object 6099_h sub index 1 and e.g. 10000 to object 6099_h sub index 2.
- Write 31 to object 6040_h to start the homing process.
- Press and release the home switch.
- When homing has finished, write 15 to object 6040_h again.



9 Cyclic synchronous Position Mode

The cyclic synchronous position mode is used to directly control the position of the motor. It contains limit functions, but not a trajectory generator. The trajectory generator is located in the control device (the master), not in the drive device. In cyclic synchronous manner, the control device provides a target position to the drive device, which performs position control, velocity control and torque control.

The main control parameters are the target position (object 607A_h, see section 9.1.7) and the interpolation time period (object 60C2_h, see section 9.1.10). The drive automatically sets the velocity in such a manner that the next target position is reached within the interpolation time period. Acceleration and deceleration ramps are not used in this mode.

The cyclic synchronous position mode covers the following sub-functions:

- Position demand value input directly via an object.
- Monitoring of the position.
- Limiting the position using the software limits or the hardware limit switches.

9.1 Detailed Object Specifications

9.1.1 Object 6040_h: Control Word

This object indicates the received command controlling the power drive system finite state automaton (PDS FSA). The CiA-402 state machine can be controlled using this object. Please refer to figure 3 for detailed information. The cyclic synchronous position mode does not use any mode specific bits of the control word.

Structure of the Control Word									
15	9	8	7	6	4	3	2	1	0
nu	h	fr	nu	eo	qs	ev	so		
MSB					LSB				

Legend: nu=not used; h=halt; fr=fault reset; eo=enable operation; qs=quick stop; ev=enable voltage; so=switch on.

Table 203: Structure of the Control Word in csp Mode



Command Coding						
Command	Bits of Control Word					Transitions
	Bit 7	Bit 3	Bit 2	Bit 1	Bit 0	
Shutdown	0	x	1	1	0	2,6,8
Switch on	0	0	1	1	1	3
Switch on & enable operation	0	1	1	1	1	3, 4
Disable voltage	0	x	x	0	x	7,9,10,12
Quick stop	0	x	0	1	x	7,10,11
Disable operation	0	0	1	1	1	5
Enable operation	0	1	1	1	1	4, 16
Fault reset	0-to-1	x	x	x	x	15

Table 204: Command Coding

Object Description			
Index	Name	Object Type	Data Type
6040 _h	Controlword	Variable	UNSIGNED16

Table 205: Object Description (6040_h in csp Mode)

Entry Description				
Sub-index	Access	PDO Mapping	Value Range	Default Value
0	rw	see CiA402-3	See command coding above.	

Table 206: Entry Description (6040_h in csp Mode)

9.1.2 Object 6041_h: Status Word

This object provides the status of the PDS FSA. It reflects the status of the CiA-402 state machine. Please refer to figure 3 for detailed information. The object is structured as defined below. For more information about the coding please refer to the CANopen Drives and motion control device profile, part 2.

Structure of the Status Word															
15	14	13	12	11	10	9	8	7	6	5	4	3	2	1	0
dir	mot	oms	ila	r	rm	ms	w	sod	qs	ve	f	oe	so	rtso	
MSB														LSB	

Legend: nu=not used; r=reserved; oms=operation mode specific; h=halt; fr=fault reset; oe=operation enable; qs=quick stop; ve=voltage enable; so=switch on.

Table 207: Structure of the Status Word in csp Mode



Trinamic Specific Bits		
Bit	Name	Definition
14	Motor activity	0: Motor stands still. 1: Motor rotates.
15	Direction of rotation	This bit shows the direction of rotation.

Table 208: Trinamic Specific Bits

Operation Mode specific Bits in csp Mode		
Bit	Name	Definition
10	Reserved	Not used.
12	Target position ignored	0: Target position ignored. 1: Target position used as input to position controller.
13	Following error	0: No following error. 1: Following error.

Table 209: Operation Mode specific Bits in csp Mode

State Coding	
Status word	FSA state
xxxx xxxx x0xx 0000 _h	Not ready to switch on
xxxx xxxx x1xx 0000 _h	Switch on disabled
xxxx xxxx x01x 0001 _h	Ready to switch on
xxxx xxxx x01x 0011 _h	Switched on
xxxx xxxx x01x 0111 _h	Operation enabled
xxxx xxxx x00x 0111 _h	Quick stop active
xxxx xxxx x0xx 1111 _h	Fault reaction active
xxxx xxxx x0xx 1000 _h	Fault

Table 210: State Coding

Object Description			
Index	Name	Object Type	Data Type
6041 _h	Controlword	Variable	UNSIGNED16

Table 211: Object Description (6041_h in csp Mode)



Entry Description				
Sub-index	Access	PDO Mapping	Value Range	Default Value
0	rw	see CiA402-3	See state coding above	

Table 212: Entry Description (6041_h in csp Mode)

9.1.3 Object 6062_h: Position Demand Value

This object provides the demanded position value. The value is given in microsteps. Object 6062_h indicates the actual position that the motor should have. It is not to be confused with objects 6063_h and 6064_h.

Object Description			
Index	Name	Object Type	Data Type
6062 _h	Position Demand Value	Variable	SIGNED32

Table 213: Object Description (6062_h)

Entry Description				
Sub-index	Access	PDO Mapping	Value Range	Default Value
0	ro	Refer to CiA402-3	SIGNED32	no

Table 214: Entry Description (6062_h)

9.1.4 Object 6063_h: Position Actual Internal Value

This object provides the demanded position value. The value is given in microsteps. It is the same as object 6062_h.

Object Description			
Index	Name	Object Type	Data Type
6063 _h	Position Actual Internal Value	Variable	SIGNED32

Table 215: Object Description (6063_h)

Entry Description				
Sub-index	Access	PDO Mapping	Value Range	Default Value
0	ro	Refer to CiA402-3	SIGNED32	no

Table 216: Entry Description (6063_h)

9.1.5 Object 6064_h: Position Actual Value

This object provides the actual value of the position measurement device. It always contains the same value as object 6063_h.



Object Description			
Index	Name	Object Type	Data Type
6064 _h	Position Actual Value	Variable	SIGNED32

Table 217: Object Description (6064_h)

Entry Description				
Sub-index	Access	PDO Mapping	Value Range	Default Value
0	ro	Refer to CiA402-3	SIGNED32	no

Table 218: Entry Description (6064_h)

9.1.6 Object 606C_h: Velocity Actual Value

This object shows the actual velocity value of the motor. The value is given in units of pps.

Object Description			
Index	Name	Object Type	Data Type
606C _h	Velocity Actual Value	Variable	SIGNED32

Table 219: Object Description (606C_h)

Entry Description				
Sub-index	Access	PDO Mapping	Value Range	Default Value
0	ro	Refer to CiA402-3	SIGNED32	no

Table 220: Entry Description (606C_h)

9.1.7 Object 607A_h: Target Position

The target position is the position that the drive should move to in cyclic synchronous position mode using the current interpolation time period. In csp mode this value is always interpreted as an absolute value.

Object Description			
Index	Name	Object Type	Data Type
607A _h	Target Position	Variable	SIGNED32

Table 221: Object Description (607A_h in csp Mode)



Entry Description				
Sub-index	Access	PDO Mapping	Value Range	Default Value
0	rw	Refer to CiA402-3	SIGNED32	0

Table 222: Entry Description (607A_h in csp Mode)

9.1.8 Object 607D_h: Software Position Limit

This object indicates the configured maximal and minimal software position limits. These parameters define the absolute position limits for the position demand value and the position actual value. Every new target position is checked against these limits. The limit positions are always relative to the machine home position. Before being compared with the target position, they are corrected internally by the home offset as follows:

$$\begin{aligned} \text{Corrected_min_position_limit} &= \text{min_position_limit} - \text{home_offset} \\ \text{Corrected_max_position_limit} &= \text{max_position_limit} - \text{home_offset} \end{aligned}$$

Object Description			
Index	Name	Object Type	Data Type
607D _h	Software Position Limit	Array	SIGNED32

Table 223: Object Description (607D_h)

Entry Description					
Sub-index	Description	Access	PDO Mapping	Value Range	Default Value
1	Minimum Position Limit	rw	no	SIGNED32	-2147483648
2	Maximum Position Limit	rw	no	SIGNED32	2147483647

Table 224: Entry Description (607D_h)

9.1.9 Object 60B0_h: Position Offset

This object provides an offset to the target position (object 607A_h, see section 9.1.7)). The value is given in microsteps and will be added to the target position.

Object Description			
Index	Name	Object Type	Data Type
60B0 _h	Offset Torque	Variable	SIGNED32

Table 225: Object Description (60B0_h)



Entry Description				
Sub-index	Access	PDO Mapping	Value Range	Default Value
0	rw	yes	-2147483648...2147483647	0

Table 226: Entry Description (60B0_h)

9.1.10 Object 60C2_h: Interpolation Time Period

This object indicates the interpolation cycle time. The interpolation time period (sub-index 01_h) is given in $10^{\text{interpolation_time_index}}$ s. The interpolation time index (sub-index 02_h) is dimensionless.

Object Description			
Index	Name	Object Type	Data Type
60C2 _h	Offset Torque	Vecord	Interpolation time period record (0080 _h)

Table 227: Object Description (60C2_h)

Entry Description					
Sub-index	Description	Access	PDO Mapping	Value Range	Default Value
0	Highest sub-index supported	ro	no	UNSIGNED8	2
1	Interpolation time period value	rw	no	UNSIGNED8	1
2	Interpolation time index	rw	no	-3...3	-3

Table 228: Entry Description (60C2_h)

10 Cyclic synchronous Velocity Mode

The cyclic synchronous velocity mode is used to directly control the velocity of the motor. It contains limit functions, but not a trajectory generator. The trajectory generator is located in the control device (the master), not in the drive device. In cyclic synchronous manner, the control device provides a target velocity to the drive device, which performs position control, velocity control and torque control.

The main control parameters are the target velocity (object 60FF_h, see section 10.1.4) and the interpolation time period (object 60C2_h, see section 10.1.7). The drive automatically sets the acceleration in such a manner that the next target velocity is reached within the interpolation time period. Acceleration and deceleration ramps are not used in this mode.

The cyclic synchronous velocity mode covers the following sub-functions:

- Velocity demand value input directly via an object.
- Monitoring of the position.
- Limiting the position using the software limits or the hardware limit switches.

10.1 Detailed Object Specifications

10.1.1 Object 6040_h: Control Word

This object indicates the received command controlling the power drive system finite state automaton (PDS FSA). The CiA-402 state machine can be controlled using this object. Please refer to figure 3 for detailed information. The cyclic synchronous velocity mode does not use any mode specific bits of the control word.

Structure of the Control Word									
15	9	8	7	6	4	3	2	1	0
nu	h	fr	nu	eo	qs	ev	so		
MSB					LSB				

Legend: nu=not used; h=halt; fr=fault reset; eo=enable operation; qs=quick stop; ev=enable voltage; so=switch on.

Table 229: Structure of the Control Word in csv Mode



Command Coding						
Command	Bits of Control Word					Transitions
	Bit 7	Bit 3	Bit 2	Bit 1	Bit 0	
Shutdown	0	x	1	1	0	2,6,8
Switch on	0	0	1	1	1	3
Switch on & enable operation	0	1	1	1	1	3, 4
Disable voltage	0	x	x	0	x	7,9,10,12
Quick stop	0	x	0	1	x	7,10,11
Disable operation	0	0	1	1	1	5
Enable operation	0	1	1	1	1	4, 16
Fault reset	0-to-1	x	x	x	x	15

Table 230: Command Coding

Object Description			
Index	Name	Object Type	Data Type
6040 _h	Controlword	Variable	UNSIGNED16

Table 231: Object Description (6040_h in csv Mode)

Entry Description				
Sub-index	Access	PDO Mapping	Value Range	Default Value
0	rw	see CiA402-3	See command coding above.	

Table 232: Entry Description (6040_h in csv Mode)

10.1.2 Object 6041_h: Status Word

This object provides the status of the PDS FSA. It reflects the status of the CiA-402 state machine. Please refer to figure 3 for detailed information. The object is structured as defined below. For more information about the coding please refer to the CANopen Drives and motion control device profile, part 2.

Structure of the Status Word															
15	14	13	12	11	10	9	8	7	6	5	4	3	2	1	0
dir	mot	oms	ila	r	rm	ms	w	sod	qs	ve	f	oe	so	rtso	
MSB														LSB	

Legend: nu=not used; r=reserved; oms=operation mode specific; h=halt; fr=fault reset; oe=operation enable; qs=quick stop; ve=voltage enable; so=switch on.

Table 233: Structure of the Status Word in csv Mode



Trinamic Specific Bits		
Bit	Name	Definition
14	Motor activity	0: Motor stands still. 1: Motor rotates.
15	Direction of rotation	This bit shows the direction of rotation.

Table 234: Trinamic Specific Bits

Operation Mode specific Bits in csv Mode		
Bit	Name	Definition
10	Reserved	Not used.
12	Target position ignored	0: Target velocity ignored. 1: Target velocity used as input to velocity controller.
13	Reserved	Not used.

Table 235: Operation Mode specific Bits in csv Mode

State Coding	
Status word	FSA state
xxxx xxxx x0xx 0000 _h	Not ready to switch on
xxxx xxxx x1xx 0000 _h	Switch on disabled
xxxx xxxx x01x 0001 _h	Ready to switch on
xxxx xxxx x01x 0011 _h	Switched on
xxxx xxxx x01x 0111 _h	Operation enabled
xxxx xxxx x00x 0111 _h	Quick stop active
xxxx xxxx x0xx 1111 _h	Fault reaction active
xxxx xxxx x0xx 1000 _h	Fault

Table 236: State Coding

Object Description			
Index	Name	Object Type	Data Type
6041 _h	Controlword	Variable	UNSIGNED16

Table 237: Object Description (6041_h in csv Mode)



Entry Description				
Sub-index	Access	PDO Mapping	Value Range	Default Value
0	rw	see CiA402-3	See state coding above	

Table 238: Entry Description (6041_h in csv Mode)

10.1.3 Object 606C_h: Velocity Actual Value

This object shows the actual velocity value of the motor. The value is given in units of pps.

Object Description			
Index	Name	Object Type	Data Type
606C _h	Velocity Actual Value	Variable	SIGNED32

Table 239: Object Description (606C_h)

Entry Description				
Sub-index	Access	PDO Mapping	Value Range	Default Value
0	ro	Refer to CiA402-3	SIGNED32	no

Table 240: Entry Description (606C_h)

10.1.4 Object 60FF_h: Target Velocity

In csv mode the target velocity specifies the velocity that is to be reached within the interpolation time period. The values are given in pps units.

Object Description			
Index	Name	Object Type	Data Type
60FF _h	Target Velocity	Variable	SIGNED32

Table 241: Object Description (60FF_h)

Entry Description				
Sub-index	Access	PDO Mapping	Value Range	Default Value
0	rw	see CiA402-3	SIGNED32	0

Table 242: Entry Description (60FF_h)

10.1.5 Object 607D_h: Software Position Limit

This object indicates the configured maximal and minimal software position limits. These parameters define the absolute position limits for the position demand value and the position actual value. Every new target position is checked against these limits. The limit positions are always relative to the machine



home position. Before being compared with the target position, they are corrected internally by the home offset as follows:

$$Corrected_min_position_limit = min_position_limit - home_offset$$

$$Corrected_max_position_limit = max_position_limit - home_offset$$

Object Description			
Index	Name	Object Type	Data Type
607D _h	Software Position Limit	Array	SIGNED32

Table 243: Object Description (607D_h)

Entry Description					
Sub-index	Description	Access	PDO Mapping	Value Range	Default Value
1	Minimum Position Limit	rw	no	SIGNED32	-2147483648
2	Maximum Position Limit	rw	no	SIGNED32	2147483647

Table 244: Entry Description (607D_h)

10.1.6 Object 60B1_h: Velocity Offset

This object provides an offset to the target velocity (object 60FF_h, see section 10.1.4)). The value will be added to the target velocity.

Object Description			
Index	Name	Object Type	Data Type
60B1 _h	Velocity Offset	Variable	SIGNED32

Table 245: Object Description (60B1_h)

Entry Description				
Sub-index	Access	PDO Mapping	Value Range	Default Value
0	rw	yes	-2147483648...2147483647	0

Table 246: Entry Description (60B1_h)

10.1.7 Object 60C2_h: Interpolation Time Period

This object indicates the interpolation cycle time. The interpolation time period (sub-index 01_h) is given in 10^{*interpolation_time_index*} s. The interpolation time index (sub-index 02_h) is dimensionless.



Object Description			
Index	Name	Object Type	Data Type
60C2 _h	Offset Torque	Vecord	Interpolation time period record (0080 _h)

Table 247: Object Description (60C2_h)

Entry Description					
Sub-index	Description	Access	PDO Mapping	Value Range	Default Value
0	Highest sub-index supported	ro	no	UNSIGNED8	2
1	Interpolation time period value	rw	no	UNSIGNED8	1
2	Interpolation time index	rw	no	-3...3	-3

Table 248: Entry Description (60C2_h)



11 Cyclic synchronous Torque Mode

The cyclic synchronous torque mode is used to directly control the torque of the motor, without the need for position or velocity control. It contains limit functions, but not a trajectory generator. The cyclic synchronous torque mode covers the following sub-functions:

- Demand value input directly via an object.
- Monitoring of the torque.
- Limiting the position using the software limits or the hardware limit switches.

11.1 Detailed Object Specifications

11.1.1 Object 6040_n: Control Word

This object indicates the received command controlling the power drive system finite state automaton (PDS FSA). The CiA-402 state machine can be controlled using this object. Please refer to figure 3 for detailed information. The cyclic synchronous torque mode does not use any mode specific bits of the control word.

Structure of the Control Word									
15	9	8	7	6	4	3	2	1	0
nu		h	fr	nu		eo	qs	ev	so
MSB					LSB				

Legend: nu=not used; h=halt; fr=fault reset; eo=enable operation; qs=quick stop; ev=enable voltage; so=switch on.

Table 249: Structure of the Control Word in cst Mode

Command Coding						
Command	Bits of Control Word					Transitions
	Bit 7	Bit 3	Bit 2	Bit 1	Bit 0	
Shutdown	0	x	1	1	0	2,6,8
Switch on	0	0	1	1	1	3
Switch on & enable operation	0	1	1	1	1	3, 4
Disable voltage	0	x	x	0	x	7,9,10,12
Quick stop	0	x	0	1	x	7,10,11
Disable operation	0	0	1	1	1	5
Enable operation	0	1	1	1	1	4, 16
Fault reset	0-to-1	x	x	x	x	15

Table 250: Command Coding



Object Description			
Index	Name	Object Type	Data Type
6040 _h	Controlword	Variable	UNSIGNED16

Table 251: Object Description (6040_h in cst Mode)

Entry Description				
Sub-index	Access	PDO Mapping	Value Range	Default Value
0	rw	see CiA402-3	See command coding above.	

Table 252: Entry Description (6040_h in cst Mode)

11.1.2 Object 6041_h: Status Word

This object provides the status of the PDS FSA. It reflects the status of the CiA-402 state machine. Please refer to figure 3 for detailed information. The object is structured as defined below. For more information about the coding please refer to the CANopen Drives and motion control device profile, part 2.

Structure of the Status Word															
15	14	13	12	11	10	9	8	7	6	5	4	3	2	1	0
dir	mot	oms	ila	r	rm	ms	w	sod	qs	ve	f	oe	so	rtso	
MSB														LSB	

Legend: nu=not used; r=reserved; oms=operation mode specific; h=halt; fr=fault reset; oe=operation enable; qs=quick stop; ve=voltage enable; so=switch on.

Table 253: Structure of the Status Word in cst Mode

Trinamic Specific Bits		
Bit	Name	Definition
14	Motor activity	0: Motor stands still. 1: Motor rotates.
15	Direction of rotation	This bit shows the direction of rotation.

Table 254: Trinamic Specific Bits



Operation Mode specific Bits in cst Mode		
Bit	Name	Definition
10	Reserved	Not used.
12	Target torque ignored	0: Target torque ignored. 1: Target torque used as input to control loop.
13	Reserved	Not used.

Table 255: Operation Mode specific Bits in cst Mode

State Coding	
Status word	FSA state
xxxx xxxx x0xx 0000 _h	Not ready to switch on
xxxx xxxx x1xx 0000 _h	Switch on disabled
xxxx xxxx x01x 0001 _h	Ready to switch on
xxxx xxxx x01x 0011 _h	Switched on
xxxx xxxx x01x 0111 _h	Operation enabled
xxxx xxxx x00x 0111 _h	Quick stop active
xxxx xxxx x0xx 1111 _h	Fault reaction active
xxxx xxxx x0xx 1000 _h	Fault

Table 256: State Coding

Object Description			
Index	Name	Object Type	Data Type
6041 _h	Controlword	Variable	UNSIGNED16

Table 257: Object Description (6041_h in cst Mode)

Entry Description				
Sub-index	Access	PDO Mapping	Value Range	Default Value
0	rw	see CiA402-3	See state coding above	

Table 258: Entry Description (6041_h in cst Mode)

11.1.3 Object 6062_h: Position Demand Value

This object provides the demanded position value. The value is given in microsteps. Object 6062_h indicates the actual position that the motor should have. It is not to be confused with objects 6063_h and 6064_h.



Object Description			
Index	Name	Object Type	Data Type
6062 _h	Position Demand Value	Variable	SIGNED32

Table 259: Object Description (6062_h)

Entry Description				
Sub-index	Access	PDO Mapping	Value Range	Default Value
0	ro	Refer to CiA402-3	SIGNED32	no

Table 260: Entry Description (6062_h)

11.1.4 Object 6063_h: Position Actual Internal Value

This object provides the demanded position value. The value is given in microsteps. It is the same as object 6062_h.

Object Description			
Index	Name	Object Type	Data Type
6063 _h	Position Actual Internal Value	Variable	SIGNED32

Table 261: Object Description (6063_h)

Entry Description				
Sub-index	Access	PDO Mapping	Value Range	Default Value
0	ro	Refer to CiA402-3	SIGNED32	no

Table 262: Entry Description (6063_h)

11.1.5 Object 6064_h: Position Actual Value

This object provides the actual value of the position measurement device. It always contains the same value as object 6063_h.

Object Description			
Index	Name	Object Type	Data Type
6064 _h	Position Actual Value	Variable	SIGNED32

Table 263: Object Description (6064_h)



Entry Description				
Sub-index	Access	PDO Mapping	Value Range	Default Value
0	ro	Refer to CiA402-3	SIGNED32	no

Table 264: Entry Description (6064_h)

11.1.6 Object 6071_h: Target Torque

This object sets the desired torque value. The value is given in mA.

Object Description			
Index	Name	Object Type	Data Type
6071 _h	Target torque	Variable	INTEGER16

Table 265: Object Description (6071_h)

Entry Description				
Sub-index	Access	PDO Mapping	Value Range	Default Value
0	rw	yes	-32768...32767	0

Table 266: Entry Description (6071_h)

11.1.7 Object 6077_h: Torque actual Value

This object provides the actual torque value. The value is given in mA.

Object Description			
Index	Name	Object Type	Data Type
6077 _h	Torque actual Value	Variable	INTEGER16

Table 267: Object Description (6077_h)

Entry Description				
Sub-index	Access	PDO Mapping	Value Range	Default Value
0	ro	yes	-32768...32767	0

Table 268: Entry Description (6077_h)

11.1.8 Object 607D_h: Software Position Limit

This object indicates the configured maximal and minimal software position limits. These parameters define the absolute position limits for the position demand value and the position actual value. Every



new target position is checked against these limits. The limit positions are always relative to the machine home position. Before being compared with the target position, they are corrected internally by the home offset as follows:

$$\begin{aligned} \text{Corrected_min_position_limit} &= \text{min_position_limit} - \text{home_offset} \\ \text{Corrected_max_position_limit} &= \text{max_position_limit} - \text{home_offset} \end{aligned}$$

Object Description			
Index	Name	Object Type	Data Type
607D _h	Software Position Limit	Array	SIGNED32

Table 269: Object Description (607D_h)

Entry Description					
Sub-index	Description	Access	PDO Mapping	Value Range	Default Value
1	Minimum Position Limit	rw	no	SIGNED32	-2147483648
2	Maximum Position Limit	rw	no	SIGNED32	2147483647

Table 270: Entry Description (607D_h)

11.1.9 Object 60B2_h: Torque Offset

This object provides an offset to the torque value. It will be added to the target torque (object 6071_h, see section 11.1.6).

Object Description			
Index	Name	Object Type	Data Type
60B2 _h	Offset Torque	Variable	SIGNED16

Table 271: Object Description (60B2_h)

Entry Description				
Sub-index	Access	PDO Mapping	Value Range	Default Value
0	rw	yes	-32768...32767	0

Table 272: Entry Description (60B2_h)

11.1.10 Object 60C2_h: Interpolation Time Period

This object indicates the interpolation cycle time. The interpolation time period (sub-index 01_h) is given in 10^{interpolation_time_index} s. The interpolation time index (sub-index 02_h) is dimensionless.



Object Description			
Index	Name	Object Type	Data Type
60C2 _h	Offset Torque	Vecord	Interpolation time period record (0080 _h)

Table 273: Object Description (60C2_h)

Entry Description					
Sub-index	Description	Access	PDO Mapping	Value Range	Default Value
0	Highest sub-index supported	ro	no	UNSIGNED8	2
1	Interpolation time period value	rw	no	UNSIGNED8	1
2	Interpolation time index	rw	no	-3...3	-3

Table 274: Entry Description (60C2_h)



12 Emergency Messages (EMCY)

The module sends an emergency message if an error occurs. The message contains information about the error type. The module can map internal errors and object 1001_h (error register) is part of every emergency object.

Emergency Messages (EMCY) of the TMC-1617						
Error code	Additional byte					Description
	1	2	3	4	5	
0000 _h	0	0	0	0	0	Fault reset The fault reset command has been executed.
1000 _h	1	0	0	0	0	Generic error: open load bridge A The motor driver indicates open load on bridge A. It is possible that the motor cable is broken or that there is an error in the power amplifier itself.
1000 _h	2	0	0	0	0	Generic error: open load bridge B The motor driver indicates open load on bridge B. It is possible that the motor cable is broken or that there is an error in the power amplifier itself.
2310 _h	0	0	0	0	0	Overcurrent high side The motor driver indicates an overcurrent on the high side. This can be caused by a short circuit in the driver stage.
2311 _h	0	0	0	0	0	Overcurrent bridge B The motor driver indicates that there is overcurrent on bridge B. This can be caused by a short circuit in the motor itself or in the motor driver stage.
2312 _h	0	0	0	0	0	Overcurrent bridge A The motor driver indicates that there is overcurrent on bridge A. This can be caused by a short circuit in the motor itself or in the motor driver stage.
3230 _h	0	0	0	0	0	stallGuard2 error The actual load value exceeds the stallGuard2 limit.
4310 _h	1	0	0	0	0	Overtemperature pre-warning The temperature in the motor driver exceeds the pre-warning limit.
4310 _h	2	0	0	0	0	Overtemperature error The motor driver has been switched off because the temperature limit has been exceeded.
5441 _h	0	255	0	0	0	Shutdown switch active The enable signal is missing (due to the shutdown switch) and the motor driver has been switched off.
6320 _h	0	255	0	0	0	Parameter error The data in the received PDO is either wrong or cannot be accepted due to the internal state of the drive.



Error code	Additional byte					Description
	1	2	3	4	5	
8611 _h	0	0	0	0	0	Following error The deviation between motor position counter and encoder position counter has exceeded the following error window.
ff00 _h	0	0	0	0	0	Undervoltage The supply voltage is too low to drive a motor.
ff01 _h	1	0	0	0	0	Positive software limit The actual position is outside the range defined by object 607d _h .
ff01 _h	2	0	0	0	0	Negative software limit The actual position is outside the range defined by object 607d _h .
ff01 _h	3	0	0	0	0	Positive limit switch The positive limit switch has been touched outside of the homing function.
ff01 _h	4	0	0	0	0	Negative limit switch The negative limit switch has been touched outside of the homing function.

Table 275: Emergency Messages (EMCY)



13 Figures Index

1	NMT State Machine	10	6	Homing Method 18	63
2	Device Model	11	7	Homing Method 19	63
3	DS402 Finite State Machine	42	8	Homing Method 21	63
4	Homing Mode Function	61	9	Home Offset	68
5	Homing Method 17	62			



14 Tables Index

1	Abbreviations used in this Manual . . .	7	53	Object Description (2057 _h)	26
2	Service Primitives	8	54	Entry Description (2057 _h)	26
3	Service Types	9	55	Object Description (2058 _h)	26
4	Object Dictionary	12	56	Entry Description (2058 _h)	26
5	Object Description (1000 _h)	13	57	Object Description (2060 _h)	27
6	Entry Description (1000 _h)	13	58	Entry Description (2060 _h)	27
7	Object Description (1001 _h)	13	59	Object Description (2070 _h)	27
8	Entry Description (1001 _h)	13	60	Entry Description (2070 _h)	27
9	Error Register Bits	14	61	Encoder Initialization Modes	28
10	Object Description (1008 _h)	14	62	Object Description (2080 _h)	28
11	Entry Description (1008 _h)	14	63	Entry Description (2080 _h)	28
12	Object Description (1009 _h)	14	64	Motor Status Flags (2101 _h)	29
13	Entry Description (1009 _h)	15	65	Object Description (2101 _h)	29
14	Object Description (100A _h)	15	66	Entry Description (2101 _h)	29
15	Entry Description (100A _h)	15	67	Object Description (2102 _h)	29
16	Object Description (1018 _h)	15	68	Entry Description (2102 _h)	30
17	Entry Description (1018 _h)	16	69	Object Description (2103 _h)	30
18	Object Description (1600 _h)	16	70	Entry Description (2103 _h)	30
19	Entry Description (1600 _h)	16	71	Object Description (2104 _h)	30
20	Object Description (1A00 _h)	17	72	Entry Description (2104 _h)	30
21	Entry Description (1A00 _h)	17	73	Object Description (2140 _h)	31
22	Sync Manager Communication Types	18	74	Entry Description (2140 _h)	31
23	Object Description (1C00 _h)	18	75	Object Description (2702 _h)	31
24	Entry Description (1C00 _h)	18	76	Entry Description (2702 _h)	31
25	Object Description (1C12 _h)	18	77	Bit Definitions (2703 _h)	32
26	Entry Description (1C12 _h)	19	78	Object Description (2703 _h)	32
27	Object Description (1C13 _h)	19	79	Entry Description (2703 _h)	32
28	Entry Description (1C13 _h)	19	80	Object Description (270E _h)	32
29	Object Description (2000 _h)	20	81	Entry Description (270E _h)	33
30	Entry Description (2000 _h)	20	82	Value Description (605A _h)	34
31	Object Description (2003 _h)	20	83	Object Description (605A _h)	34
32	Entry Description (2003 _h)	21	84	Entry Description (605A _h)	35
33	Object Description (2004 _h)	21	85	Value Description (605B _h)	35
34	Entry Description (2004 _h)	21	86	Object Description (605B _h)	35
35	Object Description (2005 _h)	21	87	Entry Description (605B _h)	35
36	Entry Description (2005 _h)	22	88	Value Description (605C _h)	35
37	Bit Definitions (2005 _h)	22	89	Object Description (605C _h)	36
38	Object Description (2006 _h)	22	90	Entry Description (605C _h)	36
39	Entry Description (2006 _h)	22	91	Value Description (605D _h)	36
40	Object Description (2041 _h)	23	92	Object Description (605D _h)	36
41	Entry Description (2041 _h)	23	93	Entry Description (605D _h)	36
42	Object Description (2042 _h)	23	94	Value Description (605E _h)	37
43	Entry Description (2042 _h)	23	95	Object Description (605E _h)	37
44	Object Description (2043 _h)	24	96	Entry Description (605E _h)	37
45	Entry Description (2043 _h)	24	97	Value Description (6060 _h)	37
46	Object Description (2050 _h)	24	98	Object Description (6060 _h)	38
47	Entry Description (2050 _h)	24	99	Entry Description (6060 _h)	38
48	Commutation Modes	25	100	Value Description (6061 _h)	38
49	Object Description (2055 _h)	25	101	Object Description (6061 _h)	38
50	Entry Description (2055 _h)	25	102	Entry Description (6061 _h)	39
51	Object Description (2056 _h)	25	103	Value Description (606A _h)	39
52	Entry Description (2056 _h)	25	104	Object Description (606A _h)	39



105	Entry Description (606A _h)	39	155	Object Description (6040 _h in pv Mode)	54
106	Object Description (608F _h)	40	156	Entry Description (6040 _h in pv Mode)	54
107	Entry Description (608F _h)	40	157	Structure of the Status Word in pv Mode	54
108	Object Description (60FD _h)	40	158	Trinamic Specific Bits	55
109	Entry Description (60FD _h)	40	159	Operation Mode specific Bits in pv Mode	55
110	Value Definition (6502 _h)	41	160	State Coding	55
111	Object Description (6502 _h)	41	161	Object Description (6041 _h in pv Mode)	55
112	Entry Description (6502 _h)	41	162	Entry Description (6041 _h in pv Mode)	56
113	Structure of the Control Word in pp Mode	43	163	Object Description (6062 _h)	56
114	Operation Mode specific Bits in pp Mode	43	164	Entry Description (6062 _h)	56
115	Command Coding	43	165	Object Description (6063 _h)	56
116	Object Description (6040 _h in pp Mode)	44	166	Entry Description (6063 _h)	56
117	Entry Description (6040 _h in pp Mode)	44	167	Object Description (6064 _h)	57
118	Structure of the Staus Word in pp Mode	44	168	Entry Description (6064 _h)	57
119	Trinamic Specific Bits	44	169	Object Description (6065 _h)	57
120	Operation Mode specific Bits in pp Mode	45	170	Entry Description (6065 _h)	57
121	State Coding	45	171	Object Description (606C _h)	58
122	Object Description (6041 _h in pp Mode)	45	172	Entry Description (606C _h)	58
123	Entry Description (6041 _h in pp Mode)	45	173	Object Description (607D _h)	58
124	Object Description (6062 _h)	46	174	Entry Description (607D _h)	58
125	Entry Description (6062 _h)	46	175	Object Description (6083 _h)	59
126	Object Description (6063 _h)	46	176	Entry Description (6083 _h)	59
127	Entry Description (6063 _h)	46	177	Object Description (6085 _h)	59
128	Object Description (6064 _h)	46	178	Entry Description (6085 _h)	59
129	Entry Description (6064 _h)	47	179	Object Description (60FF _h)	59
130	Object Description (6065 _h)	47	180	Entry Description (60FF _h)	60
131	Entry Description (6065 _h)	47	181	Supported CANopen Homing Methods	62
132	Object Description (6067 _h)	48	182	Structure of the Control Word in hm Mode	65
133	Entry Description (6067 _h)	48	183	Operation Mode specific Bits in hm Mode	65
134	Object Description (6068 _h)	48	184	Command Coding	65
135	Entry Description (6068 _h)	48	185	Object Description (6040 _h in hm Mode)	66
136	Object Description (606C _h)	48	186	Entry Description (6040 _h in hm Mode)	66
137	Entry Description (606C _h)	49	187	Structure of the Status Word in hm Mode	66
138	Object Description (607A _h in pp Mode)	49	188	Trinamic Specific Bits	66
139	Entry Description (607A _h in pp Mode)	49	189	Operation Mode specific Bits in hm Mode	67
140	Object Description (607D _h)	49	190	State Coding	67
141	Entry Description (607D _h)	50	191	Object Description (6041 _h in hm Mode)	67
142	Object Description (6081 _h)	50	192	Entry Description (6041 _h in hm Mode)	67
143	Entry Description (6081 _h)	50	193	Object Description (606C _h)	68
144	Object Description (6083 _h)	50	194	Entry Description (606C _h)	68
145	Entry Description (6083 _h)	50	195	Object Description (607C _h)	68
146	Object Description (6084 _h)	51	196	Entry Description (607C _h)	68
147	Entry Description (6084 _h)	51	197	Object Description (6098 _h)	69
148	Object Description (6085 _h)	51	198	Entry Description (6098 _h)	69
149	Entry Description (6085 _h)	51	199	Object Description (6099 _h)	69
150	Bit Definitions of Object 60F2 _h	52	200	Entry Description (6099 _h)	69
151	Object Description (60F2 _h)	52	201	Object Description (609A _h)	70
152	Entry Description (60F2 _h)	52	202	Entry Description (609A _h)	70
153	Structure of the Control Word in pv Mode	53	203	Structure of the Control Word in csp Mode	71
154	Command Coding	54			



204	Command Coding	72	240	Entry Description (606C _h)	81
205	Object Description (6040 _h in csp Mode)	72	241	Object Description (60FF _h)	81
206	Entry Description (6040 _h in csp Mode)	72	242	Entry Description (60FF _h)	81
207	Structure of the Status Word in csp Mode	72	243	Object Description (607D _h)	82
208	Trinamic Specific Bits	73	244	Entry Description (607D _h)	82
209	Operation Mode specific Bits in csp Mode	73	245	Object Description (60B1 _h)	82
210	State Coding	73	246	Entry Description (60B1 _h)	82
211	Object Description (6041 _h in csp Mode)	73	247	Object Description (60C2 _h)	83
212	Entry Description (6041 _h in csp Mode)	74	248	Entry Description (60C2 _h)	83
213	Object Description (6062 _h)	74	249	Structure of the Control Word in cst Mode	84
214	Entry Description (6062 _h)	74	250	Command Coding	84
215	Object Description (6063 _h)	74	251	Object Description (6040 _h in cst Mode)	85
216	Entry Description (6063 _h)	74	252	Entry Description (6040 _h in cst Mode)	85
217	Object Description (6064 _h)	75	253	Structure of the Status Word in cst Mode	85
218	Entry Description (6064 _h)	75	254	Trinamic Specific Bits	85
219	Object Description (606C _h)	75	255	Operation Mode specific Bits in cst Mode	86
220	Entry Description (606C _h)	75	256	State Coding	86
221	Object Description (607A _h in csp Mode)	75	257	Object Description (6041 _h in cst Mode)	86
222	Entry Description (607A _h in csp Mode)	76	258	Entry Description (6041 _h in cst Mode)	86
223	Object Description (607D _h)	76	259	Object Description (6062 _h)	87
224	Entry Description (607D _h)	76	260	Entry Description (6062 _h)	87
225	Object Description (60B0 _h)	76	261	Object Description (6063 _h)	87
226	Entry Description (60B0 _h)	77	262	Entry Description (6063 _h)	87
227	Object Description (60C2 _h)	77	263	Object Description (6064 _h)	87
228	Entry Description (60C2 _h)	77	264	Entry Description (6064 _h)	88
229	Structure of the Control Word in csv Mode	78	265	Object Description (6071 _h)	88
230	Command Coding	79	266	Entry Description (6071 _h)	88
231	Object Description (6040 _h in csv Mode)	79	267	Object Description (6077 _h)	88
232	Entry Description (6040 _h in csv Mode)	79	268	Entry Description (6077 _h)	88
233	Structure of the Status Word in csv Mode	79	269	Object Description (607D _h)	89
234	Trinamic Specific Bits	80	270	Entry Description (607D _h)	89
235	Operation Mode specific Bits in csv Mode	80	271	Object Description (60B2 _h)	89
236	State Coding	80	272	Entry Description (60B2 _h)	89
237	Object Description (6041 _h in csv Mode)	80	273	Object Description (60C2 _h)	90
238	Entry Description (6041 _h in csv Mode)	81	274	Entry Description (60C2 _h)	90
239	Object Description (606C _h)	81	275	Emergency Messages (EMCY)	92
			276	Firmware Revision	99
			277	Document Revision	99



15 Supplemental Directives

15.1 Producer Information

15.2 Copyright

TRINAMIC owns the content of this user manual in its entirety, including but not limited to pictures, logos, trademarks, and resources. © Copyright 2021 TRINAMIC. All rights reserved. Electronically published by TRINAMIC, Germany.

Redistributions of source or derived format (for example, Portable Document Format or Hypertext Markup Language) must retain the above copyright notice, and the complete Datasheet User Manual documentation of this product including associated Application Notes; and a reference to other available product-related documentation.

15.3 Trademark Designations and Symbols

Trademark designations and symbols used in this documentation indicate that a product or feature is owned and registered as trademark and/or patent either by TRINAMIC or by other manufacturers, whose products are used or referred to in combination with TRINAMIC's products and TRINAMIC's product documentation.

This CoE Firmware Manual is a non-commercial publication that seeks to provide concise scientific and technical user information to the target user. Thus, trademark designations and symbols are only entered in the Short Spec of this document that introduces the product at a quick glance. The trademark designation /symbol is also entered when the product or feature name occurs for the first time in the document. All trademarks and brand names used are property of their respective owners.

15.4 Target User

The documentation provided here, is for programmers and engineers only, who are equipped with the necessary skills and have been trained to work with this type of product.

The Target User knows how to responsibly make use of this product without causing harm to himself or others, and without causing damage to systems or devices, in which the user incorporates the product.

15.5 Disclaimer: Life Support Systems

TRINAMIC Motion Control GmbH & Co. KG does not authorize or warrant any of its products for use in life support systems, without the specific written consent of TRINAMIC Motion Control GmbH & Co. KG.

Life support systems are equipment intended to support or sustain life, and whose failure to perform, when properly used in accordance with instructions provided, can be reasonably expected to result in personal injury or death.

Information given in this document is believed to be accurate and reliable. However, no responsibility is assumed for the consequences of its use nor for any infringement of patents or other rights of third parties which may result from its use. Specifications are subject to change without notice.

15.6 Disclaimer: Intended Use

The data specified in this user manual is intended solely for the purpose of product description. No representations or warranties, either express or implied, of merchantability, fitness for a particular purpose



or of any other nature are made hereunder with respect to information/specification or the products to which information refers and no guarantee with respect to compliance to the intended use is given.

In particular, this also applies to the stated possible applications or areas of applications of the product. TRINAMIC products are not designed for and must not be used in connection with any applications where the failure of such products would reasonably be expected to result in significant personal injury or death (safety-Critical Applications) without TRINAMIC's specific written consent.

TRINAMIC products are not designed nor intended for use in military or aerospace applications or environments or in automotive applications unless specifically designated for such use by TRINAMIC. TRINAMIC conveys no patent, copyright, mask work right or other trade mark right to this product. TRINAMIC assumes no liability for any patent and/or other trade mark rights of a third party resulting from processing or handling of the product and/or any other use of the product.

15.7 Collateral Documents & Tools

This product documentation is related and/or associated with additional tool kits, firmware and other items, as provided on the product page at: www.trinamic.com.



16 Revision History

16.1 Firmware Revision

Version	Date	Author	Description
V1.06	2020-MAR-25	ED/OK	First release.

Table 276: Firmware Revision

16.2 Document Revision

Version	Date	Author	Description
V1.00	2020-MAR-26	OK	First release.

Table 277: Document Revision

