

# TMCM-IF



## Hardware Manual

Version: 1.02  
February 16, 2009



Trinamic Motion Control GmbH & Co KG  
Sternstraße 67  
D - 20 357 Hamburg, Germany  
<http://www.trinamic.com>

# Table of Contents

1	Life support policy.....	3
2	Features.....	4
3	Order Codes.....	5
4	Electrical and Mechanical Interfacing.....	6
4.1	Dimensions.....	6
4.2	Connectors.....	6
4.2.1	Connecting the Modules.....	7
4.2.2	Add-on-board Connector 1 (Terminal).....	7
4.2.3	Add-on-board Connector 2 / Base Connector 2 (CAN & SPI).....	8
4.2.4	Add-on-board Connector 3 / Base Connector 3.....	8
4.2.5	Add-on-board Connector 4 (D-SUB).....	9
4.3	DIP switches.....	9
4.3.1	Switch 100 - Mode and interface addresses setting.....	10
4.3.2	Switch 101 - Interface selection 1.....	10
4.3.3	Switch 102 - Interface selection 2.....	10
5	Functional Description.....	11
5.1	System Architecture.....	11
5.2	Interface Selection through DIP switches.....	11
5.2.1	RS422 Configuration.....	11
5.2.2	RS232 Configuration.....	12
5.2.3	CAN Configuration.....	12
5.2.4	RS485 Configuration.....	12
5.2.5	USB Configuration.....	12
5.3	Address setting (depending on firmware version).....	12
5.4	IN7 or party/single mode setting by DIP switch.....	13
5.5	Home input.....	13
5.6	Encoder connection.....	13
5.7	Reference switches.....	13
5.8	LEDs.....	13
6	Operational Ratings.....	14
7	Revision History.....	15
7.1	Document Revision.....	15
7.2	Hardware Revision.....	15
8	References.....	16

# 1 Life support policy

TRINAMIC Motion Control GmbH & Co. KG does not authorize or warrant any of its products for use in life support systems, without the specific written consent of TRINAMIC Motion Control GmbH & Co. KG.

Life support systems are equipment intended to support or sustain life, and whose failure to perform, when properly used in accordance with instructions provided, can be reasonably expected to result in personal injury or death.

© TRINAMIC Motion Control GmbH & Co. KG 2007

Information given in this data sheet is believed to be accurate and reliable. However no responsibility is assumed for the consequences of its use nor for any infringement of patents or other rights of third parties, which may result from its use.

Specifications subject to change without notice.

---

## 2 Features

The TMCM-IF standard add-on board adds a number of communication interfaces to the TMCM-102 [TMCM-102] and the TMCM-142 [TMCM-142] base boards and makes several I/O signals (including encoder interface / reference switch / input / output signals) available through easy to use spring clips (which are otherwise just available through the on-board 2-row female connector).

### Applications

- add-on board for the TMCM-102 and TMCM-142 controller / driver
- interfaces and module addresses selectable through DIP switches

### Electrical data

- power supply through TMCM-102 base board
- +5V output (50mA) on spring connector

### Interface

- either RS422, RS232, CAN, RS485 or USB
- selection of interface by onboard DIP switches
- additional DIP switches for address setting (RS485 and CAN)
- 3 optically isolated inputs (Limit A and Limit B and IN9) for reference switches
- encoder interface (A/B/N), single ended + encoder power supply (+5V, 50mA max.)
- 2 general purpose digital outputs

### Other

- RoHS compliant

## 3 Order Codes

The TMCM-IF is currently available together with two different baseboards as part of the following modules:

Order code	Description	Dimensions [mm <sup>3</sup> ]
TMCM-102-IF	Single axis stepper motor controller/driver, 3.5A RMS, 48V, with encoder feedback and the standard adapter/interface board TMCM-IF	76x70x33
TMCM-142-IF	Single axis stepper motor controller/driver, 5A RMS, 75V, with encoder feedback and the standard adapter/interface board TMCM-IF	76x70x33

**Table 3.1: Order codes**

## 4 Electrical and Mechanical Interfacing

### 4.1 Dimensions

In combination with a base board the overall height is increased to at least 33mm. Be aware that the D-SUB connector of the add-on board is placed upright.

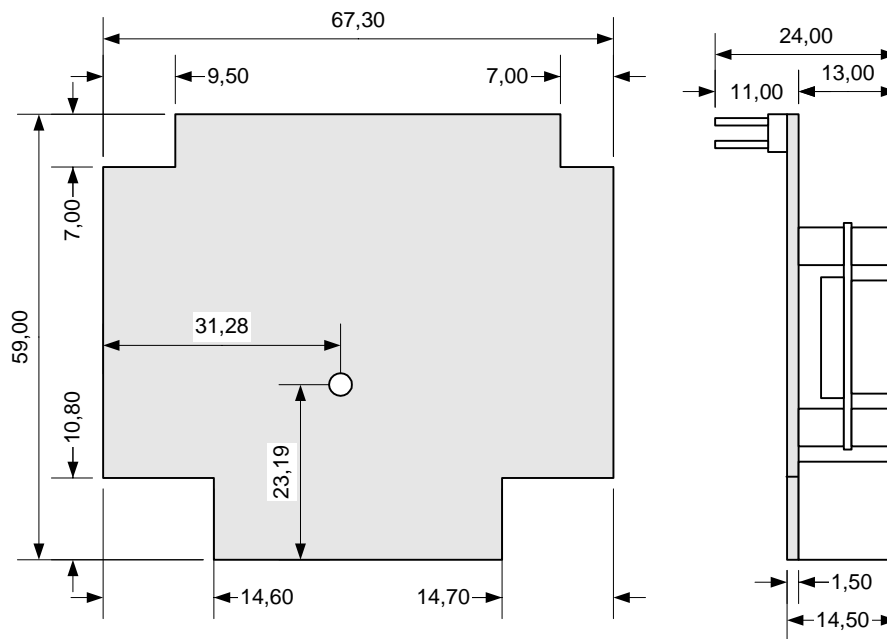

Figure 4.1: Dimensions

### 4.2 Connectors

The connectors onboard the TMC-IF adapter/interface add-on-board are

- Connector 1: 14 pole terminal (PHOENIX\_FFKDSH-254-14)
- Connector 2: D-SUB, female
- Connector 3: STILEI-2x17\_jumper, (2.54mm pitch pin connector)
- Connector 4: STILEI-2x4\_jumper, (2.54mm pitch pin connector)
- USB-type-B\_4\_H, USB type B socket, horizontal

### 4.2.1 Connecting the Modules

The TMCM-102-IF / TMCM-142-IF module consists of two PCBs: the base board and the TMCM-IF adapter board.

**Attention: Never connect or disconnect the modules while they are powered on.**

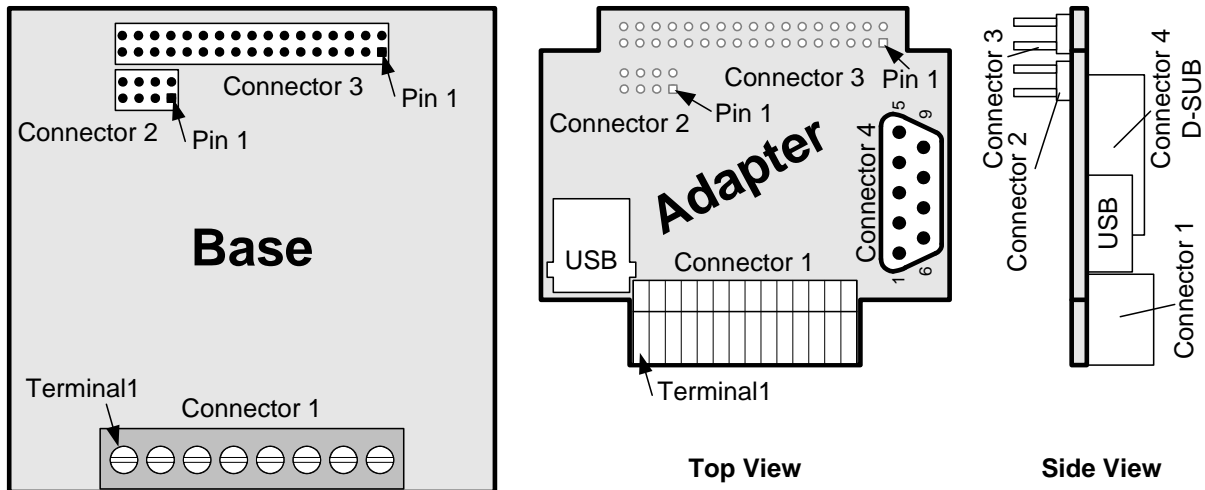

Figure 4.2: The TMCM-IF module and its connectors

### 4.2.2 Add-on-board Connector 1 (Terminal)

Terminal	Name	Function
1	Opto+5V	Input: +5V power supply for onboard optocouplers to enable IN8, IN9, Limit A and Limit B
2	GND	Ground
3	Stop Right	Optically isolated (on base board), active low limit switch input "Right"
4	Stop Left	Optically isolated (on base board), active low limit switch input "Left"
5	Home input	Optically isolated (on base board), active low input (refer to 5.5)
6	OUT_0	User controlled output #0. No internal resistors. Powers blue LED.
7	OUT_1	User controlled output #1. No internal resistors. Powers blue LED.
8	ADIN0	User controlled input #0. No internal resistors.
9	ADIN1	User controlled input #1. No internal resistors. <i>In early board versions: Active low input to stop indexing using acceleration ramp.</i>
10	+5V	Output: +5V power supply, 50mA max.
11	ENC_A+	Encoder input A+ for single ended encoders, TTL levels
12	ENC_B+	Encoder input B+ for single ended encoders, TTL levels
13	ENC_N+	Encoder input N+ for single ended encoders, TTL levels
14	GND	Ground

Table 4.1: Add-on-board Connector 1 (Terminal)

### 4.2.3 Add-on-board Connector 2 / Base Connector 2 (CAN & SPI)

Pin	Name	Function	PIN	Name	Function
1	CANH	CAN input High	2	MISO	SPI serial input (master in slave out)
3	CANL	CAN input Low	4	MOSI	SPI serial output (master out slave in)
5	GND	Ground	6	SPI_CLK	SPI serial clock
7	+5V	+5V supply	8	CS_EXT	SPI low active device select

Table 4.2: Add-on-board Connector 2 / Base Connector 2 (CAN & SPI)

### 4.2.4 Add-on-board Connector 3 / Base Connector 3

Pin	Name	Function	PIN	Name	Function
1	TX-	RS422 Transmit - (data out from indexer)	2	TX+	RS422 Transmit + (data out from indexer)
3	RX-	RS422 Receive - (data into indexer)	4	RX+	RS422 Receive + (data out from indexer)
5		Internally pulled down via 2k7 resistor. Not supported by TMCL.	6	IN <sub>0</sub> _A/D	Analog user controlled input #0. No internal resistors.
7	REF R	Optically isolated, active low limit switch input "Right"	8	STEP_OUT/RXD	Step clock output from indexer RS232 option: RS232 receive
9	OUT_1	User controlled output #1. No internal resistors.	10	DIR_OUT/TXD	Direction output from indexer. RS232 option: RS232 transmit
11	IN7	Digital user controlled input #7. Optically isolated, active low (needs power supply on pin 15)	12	ENC_A-	Differential encoder: Channel A-input (optional)
13	IN <sub>2</sub> _A/D	Analog user controlled input #2. No internal resistors.	14	ENC_B-	Differential encoder: Channel B-input (optional)
15	+5V	DC bias for input opto couplers	16	+5VDC	Logic supply out for encoder
17	OUT_0	User controlled output #0. No internal resistors.	18	ENC_N-	Differential encoder: Channel N-input (optional)
19	REF L	Optically isolated, active low limit switch input "Left"	20	GND	Logic supply ground connection
21	IN <sub>3</sub>	Digital user controlled input #3. No internal resistors. (TTL)	22	OUT_2	User controlled output #2. No internal resistors.
23	IN8	Digital user controlled input #8. Optically isolated, active low (needs power supply on pin 15)	24		Not supported by TMCL.
25	IN <sub>5</sub>	Digital user controlled input #5. No internal resistors. (TTL)	26	IN <sub>1</sub> _A/D	Analog user controlled input #1. No internal resistors.
27	ALARM	High voltage open collector output indicating driver fault condition.	28		Not supported by TMCL.
29	ENC_N+	Encoder option: Single ended: Channel N input Differential: Channel N+ input	30	IN6	Digital user controlled input #6. No internal resistors. (TTL)
31	FS	Active for one clock pulse at each on-pole fullstep position.	32	IN4	Digital user controlled input #4. No internal resistors. (TTL)
33	ENC_B+	Encoder option: Single ended: Channel B input Differential: Channel B+ input	34	ENC_A+	Encoder option: Single ended: Channel A input Differential: Channel A+ input

Table 4.3: Add-on-board Connector 3 / Base Connector 3



### 4.2.5 Add-on-board Connector 4 (D-SUB)

The DIP switch setting (refer to 5.2) controls the signals/interface off the D-SUB connector.

Terminal	CAN	RS232	RS485	RS422
1				
2	CANL	RXD	RS485-	TX-
3	GND	TXD		
4				RX-
5	GND	GND	GND	GND
6				
7	CANH		RS485+	TX+
8				RX+
9				

Table 4.4: Add-on-board Connector 4 (D-SUB)

### 4.3 DIP switches

DIP switch 100 adjusts the address of the CAN and RS-422 interfaces. Only one of these interfaces can be used at a time. Switch 101 and 102 select the different interfaces (RS422 or RS232, CAN, RS485 and USB).

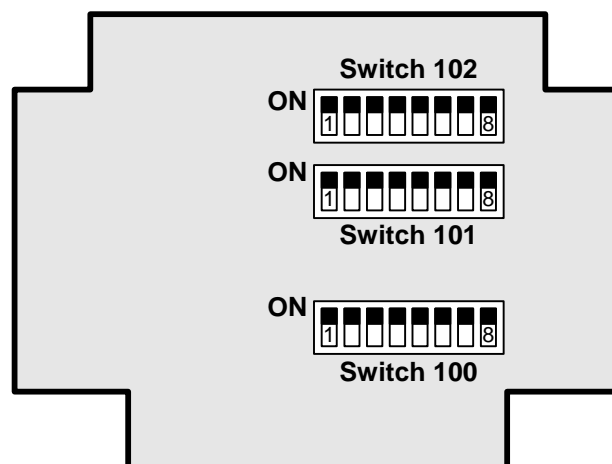

Figure 4.3: DIP switches

### 4.3.1 Switch 100 - Mode and interface addresses setting

Switch	Name	Function
1	IN7	ON: optocoupler active (if +5V at pin 15)
		OFF
2		address setting (depending on firmware version), Refer to chapter 5.3
3		
4		
5		
6		
7		
8		

Table 4.5: Switch 100 – Mode and interface address setting

### 4.3.2 Switch 101 – Interface selection 1

For further information how to activate different interfaces refer to 5.2.

Switch	Name	Function
1	CAN L	CAN Low
2	CAN H	CAN High
3	GND	CAN ground
4	232-RXD	RS232 RxD (input)
5	232-TXD	RS232 TxD (output)
6	TX+	RS232 and USB conjunction
7	RX+	USB conjunction
8	RX+	RS232 conjunction

Table 4.6: Switch 101 – Interface selection 1

### 4.3.3 Switch 102 – Interface selection 2

For further information how to activate different interfaces refer to 5.2.

Switch	Name	Function
1	Term	Termination of CAN, RS485 and RS422 (TX+, TX-)
2	TX+	RS485 (+) / RS422 (output)
3	TX-	RS485 (+) / RS422 (output)
4	RX-	RS485 (-)
5	RX+	RS485 (-)
6	RX+	RS422 (input)
7	RX-	RS422 (input)
8	Term	Termination of RS422 RX+ and RX- only

Table 4.7: Switch 102 – Interface selection 2

## 5 Functional Description

In Figure 5.1 the main parts of the TMC-IF add on module are shown in combination with the TMC-102 base board. The module mainly consists of the interfaces and connectors to get access to the base boards functions.

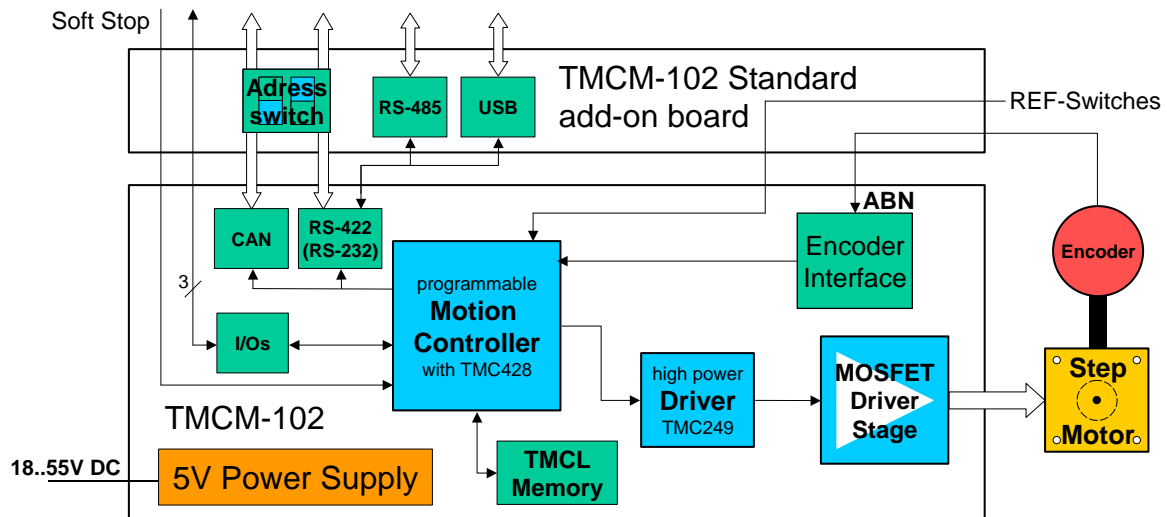

Figure 5.1: Main parts of the TCM-IF adapter/interface add-on-board

### 5.1 System Architecture

With the adapter board the large amount of possibilities provided by the base board can be customized and easily accessed.

The standard adapter board provides five interface variants, RS422, RS485, CAN, RS232 and USB, witch can be adjusted via onboard dip switches. Also it has 14 easy accessible I/Os such as limit switches, encoder interface, etc.

### 5.2 Interface Selection through DIP switches

Switch 101 and 102 select the different interfaces (RS422 or RS232, CAN, RS485 and USB).

#### 5.2.1 RS422 Configuration

To select the RS422 interface, configure the DIP switches 101 and 102 as follows:

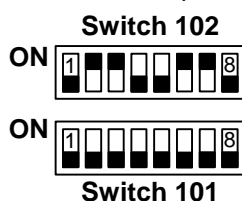

Additionally the termination can be activated by changing switch 1 and 8 of Switch 102 to ON.

## 5.2.2 RS232 Configuration

To select the RS232 interface, configure the DIP switches 101 and 102 as follows:

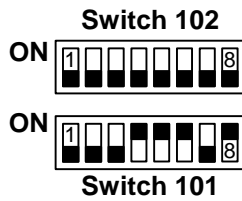

## 5.2.3 CAN Configuration

To select the CAN interface, configure the DIP switches 101 and 102 as follows:

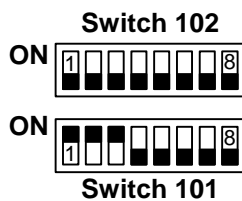

Additionally the termination can be activated by changing switch 1 of Switch 102 to ON.

## 5.2.4 RS485 Configuration

To select the RS485 interface, configure the DIP switches 101 and 102 as follows:

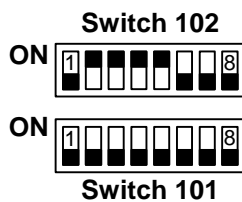

Additionally the termination can be activated by changing switch 1 of Switch 102 to ON.

## 5.2.5 USB Configuration

To select the USB interface, configure the DIP switches 101 and 102 as follows:

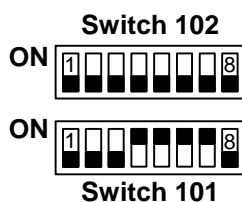

## 5.3 Address setting (depending on firmware version)

Address setting is possible via TMCL.

DIP switch 100, switches 2 to 8 adjust the address of the CAN and RS-422 interfaces. Only one of these interfaces can be used at a time. The address setting depends on the firmware version.



## 5.4 IN7 or party/single mode setting by DIP switch

With TMCL firmware: The input IN7 on pin 11 of connector 3 can be set by switch 1 of Switch 100. Additionally the +5V optocoupler supply on the terminal connector pin 14 has to be connected. The +5V output on pin 5 can be used. Switching to ON pulls IN7 to ground. The IN7 input of the TMCM-102/TMCM-142 base board is low active. The status can be read with GIO 7, 0.

Same applies for the IMS firmware. Switch OFF enables single mode and ON party mode.

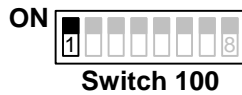

## 5.5 Home input

The home input is equivalent to the input IN8 using TMCL firmware. The status can be read with GIO 8, 0. With IMS firmware use "]1" or the "F" command.

## 5.6 Encoder connection

The TMCM-IF add-on-board provides a single ended encoder interface. Use the encoder entrances ENC\_A+ for A (Terminal pole 4), ENC\_B+ for B (pole 3) and ENC\_N+ for N (pole 2). The +5V DC supply voltage (pole 5) can be used for the encoder. For greater orders differential encoders can be supported on request, also.

## 5.7 Reference switches

Two digital reference / stop switch inputs are provided (LIMIT B = stop left and LIMIT A = stop right). They are used as an absolute position reference for homing and to set a hardware limit for the motion range. The inputs are optically isolated, active low and use TTL levels.

## 5.8 LEDs

LED	Labeled	Function
ERROR	D100	Lights at driver fault condition
OUT <sub>2</sub>	D101	User controlled output #2 indicator, lights when "1" (not accessible by connector)
OUT <sub>0</sub>	D102	User controlled output #0 indicator, lights when "1"
OUT <sub>1</sub>	D103	User controlled output #1 indicator, lights when "1"

Table 5.1: LEDs

## 6 Operational Ratings

The operational ratings show the intended / the characteristic range for the values and should be used as design values. In no case shall the maximum values be exceeded.

Symbol	Parameter	Min	Typ	Max	Unit
$U_{+5V}$	+5V output (max. 150mA load)	4.8	5.0	5.2	V
$V_{ISO}$	Isolation voltage of optocoupler		$\pm 42$	$\pm 100$	V
$V_{OPTON}$	Signal active voltage at enable, step and direction input (optocoupler on)	4	5	5.2	V
$I_{OPTON}$	Signal current for optocoupler (internally limited)	2.5	15	30	mA
$V_{OPTOFF}$	Signal inactive voltage at enable, step and direction input (optocoupler off)	-1	0	1.5	V
$V_{ANA}$	GPIO analog measurement range (20k voltage divider in high range)		0 ... 5 0 ... 10		V
$V_{STOPLO}$	StopL, StopR low level input		0	0.9	V
$V_{STOPHI}$	StopL, StopR high level input (integrated 10k pullup to +5V)	1.9	5		V
$T_{ENV}$	Environment temperature at rated current (no cooling)	-40		+60	°C
	Environment temperature at 80 % of rated current or 50% duty cycle (no cooling)	-40		+80	°C

**Table 6.1: Operational Ratings**

# 7 Revision History

## 7.1 Document Revision

Version	Date	Author	Description
0.90	11-Oct-2006	HC	Initial Version
0.91	9-Feb-2007	HC	Update to hardware version 1.1
0.92	2-Apr-2007	GE	Several corrections / updates
1.00	13-June-2007	HC	Pinning of connector 1 corrected
1.01	12-Sep-2007	HC	Several corrections, IN/OUT start at 0
1.02	2009-02-16	GE	Changed name to TMC-IF

Table 7.1: Document Revisions

## 7.2 Hardware Revision

Version	Date	Description
1.00	2006-10-04	First prototypes
1.01	2007-02-12	
1.02	2007-09-13	

Table 7.2: Hardware Revisions

## 8 References

- [TMCL] TMCL manual (see <http://www.trinamic.com>)  
[TMC-102] TMC-102 manual (see <http://www.trinamic.com>)  
[TMC-142] TMC-142 manual (see <http://www.trinamic.com>)