

Latch, Nano Power Hall-Effect Switch IC

1 Product Description

The MT882X family is produced with CMOS technology. The Hall IC internally includes high sensitivity horizontal hall plates, sleep/awake logics for mode control, a low-power on-chip oscillator, low noise analog signal chain with dynamic offset cancellation, hysteresis comparators and an output driver, Frequency switching through the connection of the Ctrl pin.

When the magnetic flux density (B) is greater than the operating point (BOP), the output turns on (Low). The output is held steady till the magnetic flux density (B) is less than the releasing point (BRP), at which point it turns off (High).

The MT882X family provides a variety of packages to customers: DFN1616 & SOT-23 for surface mount, All packages are RoHS compliant.

2 Features

- CMOS Technology
- Latch Switch
- 1.6~5V Operating Vcc Range
- -40°C~85°C Operating Temperature
- Package Option:
 - SOT-23
 - DFN1616
- Magnetic Sensitivity Option:
 - BOP=20Gs, BRP=-20Gs
- Variable frequency
 - MT8822DT-1616:
 - Ctrl pin to High: 1.2KHz
 - Ctrl pin to GND or NC: 20Hz
 - MT8823AT:
 - 1.2KHz
- Push-pull Output
- RoHS Compliant: (EU)2015/863

3 Product Overview of MT882X

Part No.	Description
MT8822DT-1616	DFN1616, tape & reel (3000pcs/bag)
MT8823AT	SOT-23, tape & reel (3000pcs/bag)

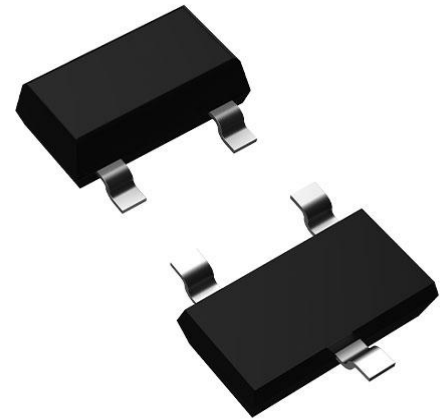

4 Applications

- Intelligent sports equipment
- Smart Home

5 Pin Configuration and Functions

	Vcc	Out	GND	Ctrl
SOT-23	1	2	3	NA
DFN1616	4	5	2	3
Description	Power	Push-pull	Ground	Ctrl

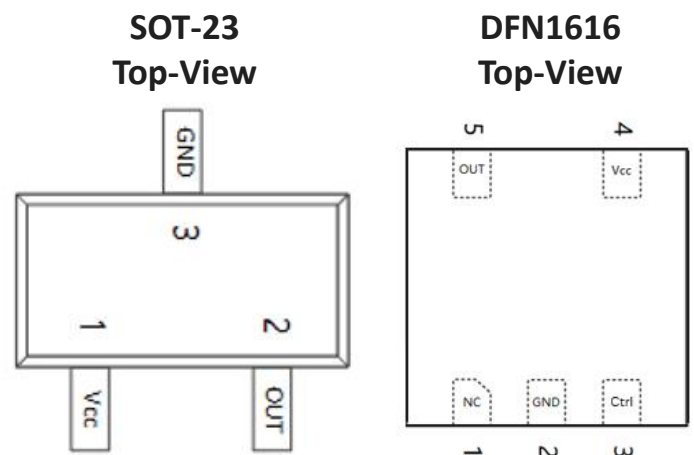

Figure.1 Pin Configuration & Functions

Table of Contents

1	Product Description.....	1
2	Features.....	1
3	Product Overview of MT882X	1
4	Applications.....	1
5	Pin Configuration and Functions.....	1
6	Definition of Switching Function.....	3
7	Function Description.....	3
8	Feature Description.....	3
9	Functional Block Diagram.....	4
10	Electrical and Magnetic Characteristics.....	4
	10.1 Absolute Maximum Ratings.....	4
	10.2 Electrical Specifications.....	5
	10.3 Magnetic Characteristics.....	6
	10.4 ESD Ratings.....	6
	10.5 Characteristic Performance.....	7
	10.6 Typical Output Waveform.....	8
11	Typical Application Circuit.....	9
12	Package Material Information.....	10
	12.1 SOT-23 Package Information.....	10
	12.2 DFN1616 Package Information.....	11
13	Copy Rights and Disclaimer.....	12

Reversion History

1	1.0 Originally Version	
2	1.1 Version	Update MT8823AT

6 Definition of Switching Function

Figure.2 & Figure.3 show the device functionality and hysteresis

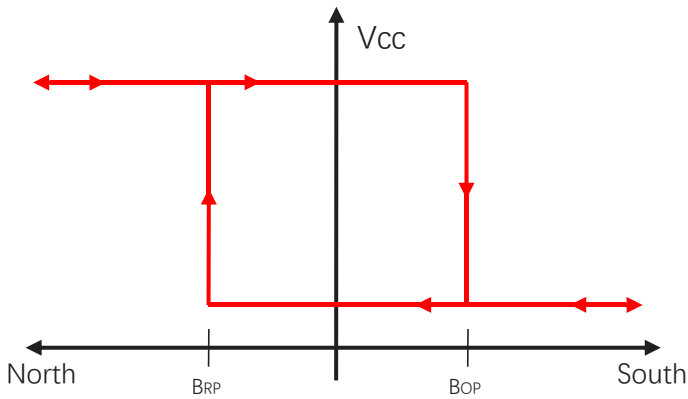

Figure.2 Switching Function of DFN1616

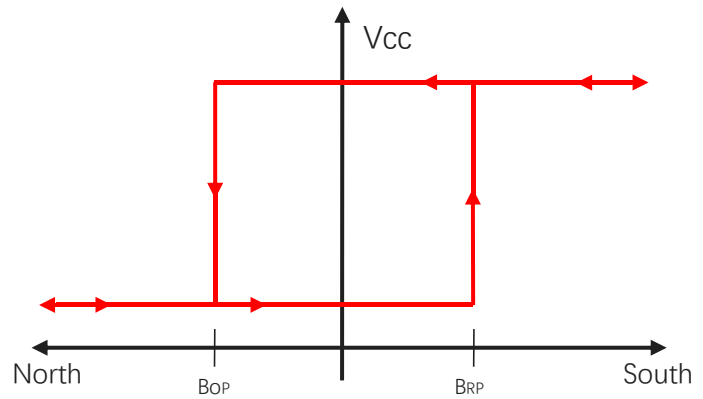

Figure.3 Switching Function of SOT-23

7 Function Description

B_{OP}: Operating Point, Magnetic flux density applied on the branded side of the package which turns the output driver ON ($V_{OUT}=Low$)

B_{RP}: Releasing Point, Magnetic flux density applied on the branded side of the package which turns the output driver OFF ($V_{OUT}=High$)

B_{HYST}: Hysteresis Window, $|B_{OP} - B_{RP}|$

Devices that have a lower magnetic threshold ($V_{OUT}=High$) detect magnets at a farther distance. Higher thresholds ($V_{OUT}=Low$) generally require a closer distance or larger magnet.

8 Feature Description

The MT882X device is sensitive to the magnetic field component that is perpendicular to the top of the package

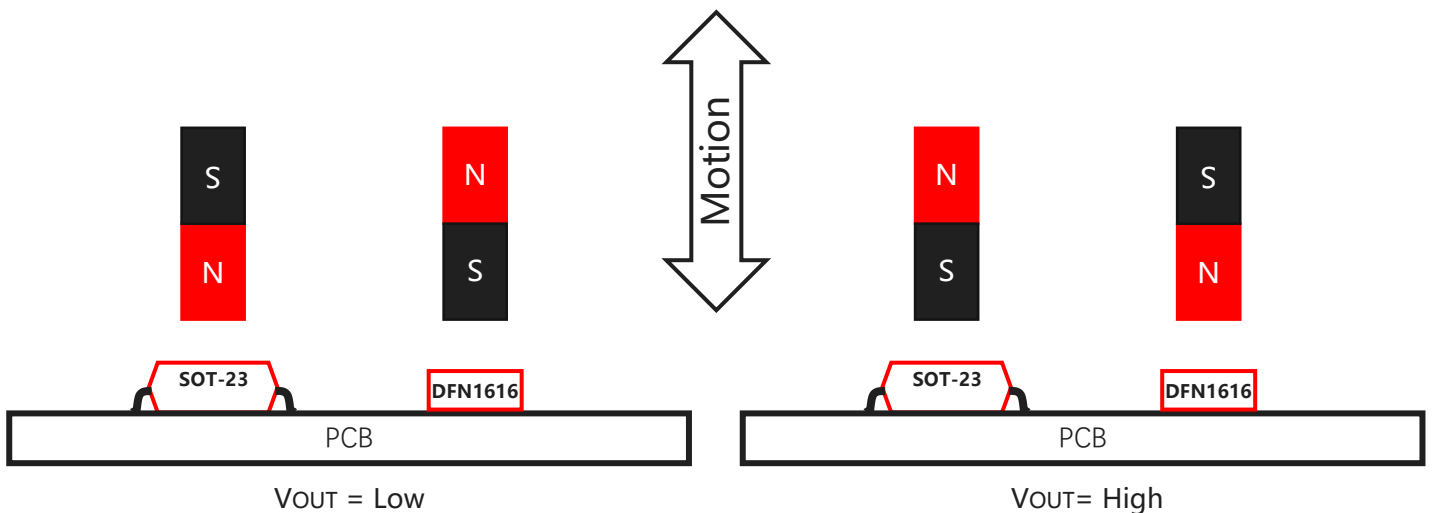

Figure.4 Flux Direction Polarity

9 Functional Block Diagram

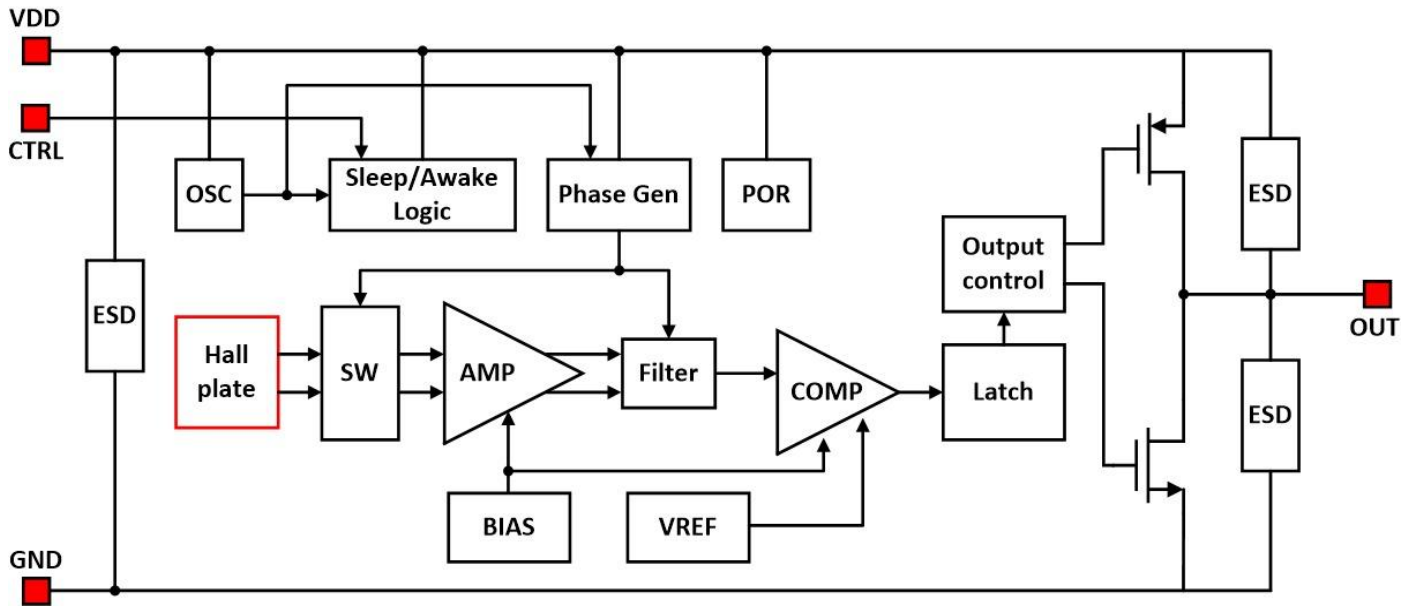

Figure.5 Functional Block Diagram

10 Electrical and Magnetic Characteristics

10.1 Absolute Maximum Ratings

Absolute maximum ratings are limited values to be applied individually, and beyond which the serviceability of the circuit may be impaired. Functional operability is not necessarily implied. Exposure to absolute maximum rating conditions for an extended period of time may affect device reliability.

Symbol	Parameters	Min	Max	Units
VCC	Supply Voltage	-	7	V
VRCC	Reverse Battery Voltage	-0.5	-	V
VOUT	Output Voltage	-	7	V
VCTRL	Ctrl Voltage	-0.5	7	V
IOUT	Continuous Output Current	-	3	mA
TA	Operating Ambient Temperature	-40	85	°C
TS	Storage Temperature	-50	150	°C
TJ	Junction Temperature	-	165	°C
B	Magnetic Flux Density	No Limit		Gs

10.2 Electrical Specifications

At TA=-40~85°C, VCC=1.6V~5V (unless otherwise specified)

Symbol	Parameters	Test Condition	Min	Typ	Max	Unit
VCC	Supply Voltage	Operating	1.6	-	5	V
ICC	Supply Current VCC=3.3V	MT8822: Ctrl pin to GND or NC	-	1.7	-	uA
		MT8822: Ctrl pin to High	-	60	-	uA
		MT8823	-	60	-	uA
I _{AW}	Awake Current	VCC=3.3V	-	2.5	-	mA
I _{SL}	Sleep Current	VCC=3.3V	-	1.0	-	uA
V _{OL}	Output Low Voltage	I _{OUT} =1mA, B > B _{OP}	-	-	0.4	V
V _{OH}	Output High Voltage	I _{OUT} =1mA, B < B _{RP}	VCC-0.4	-	-	V
F _{SW}	Switching Frequency	MT8822: Ctrl pin to GND or NC	10	20	40	Hz
		MT8822: Ctrl pin to High	1	1.2	2.5	KHz
		MT8823	1	1.2	2.5	KHz
T _{AW}	Awake Time	MT8822: Ctrl pin to GND or NC	6	10	24	us
		MT8822: Ctrl pin to High	-	10	-	us
		MT8823	-	10	-	us
T _{SL}	Sleep Time	MT8822: Ctrl pin to GND or NC	25	50	80	ms
		MT8822: Ctrl pin to High	-	0.83	-	ms
		MT8823	-	0.83	-	ms
D.C.	Duty Cycle	MT8822: Ctrl pin to GND or NC	-	0.02	-	%
		MT8822: Ctrl pin to High	-	1.2	-	%
		MT8823	-	1.2	-	%
T _{PO}	Power on Time	dVCC/dt>5V/us, B > B _{OP}	-	-	120	us
R _{TH}	Thermal Resistance of SOT-23		-	301	-	°C/W
	Thermal Resistance of DFN		-	301	-	°C/W

10.3 Magnetic Characteristics

At VCC=1.6V~5V (unless otherwise specified)

Part No.	Symbol	Min	Typ	Max	Unit
MT882X Series	BOP, TA =25°C	10	20	30	Gs
	BRP, TA =25°C	-30	-20	-10	Gs
	BHYST, TA =25°C	20	40	60	Gs

10.4 ESD Ratings

Symbol		Reference	Values	Unit
VESD	Human-body model (HBM)	AEC-Q100-002	±4500	V
	Charged-device model (CDM)	AEC-Q100-011	±1000	V

10.5 Characteristic Performance

At $V_{CC}=3.3V$, MT8823AT has only one state when CTRL is connected high

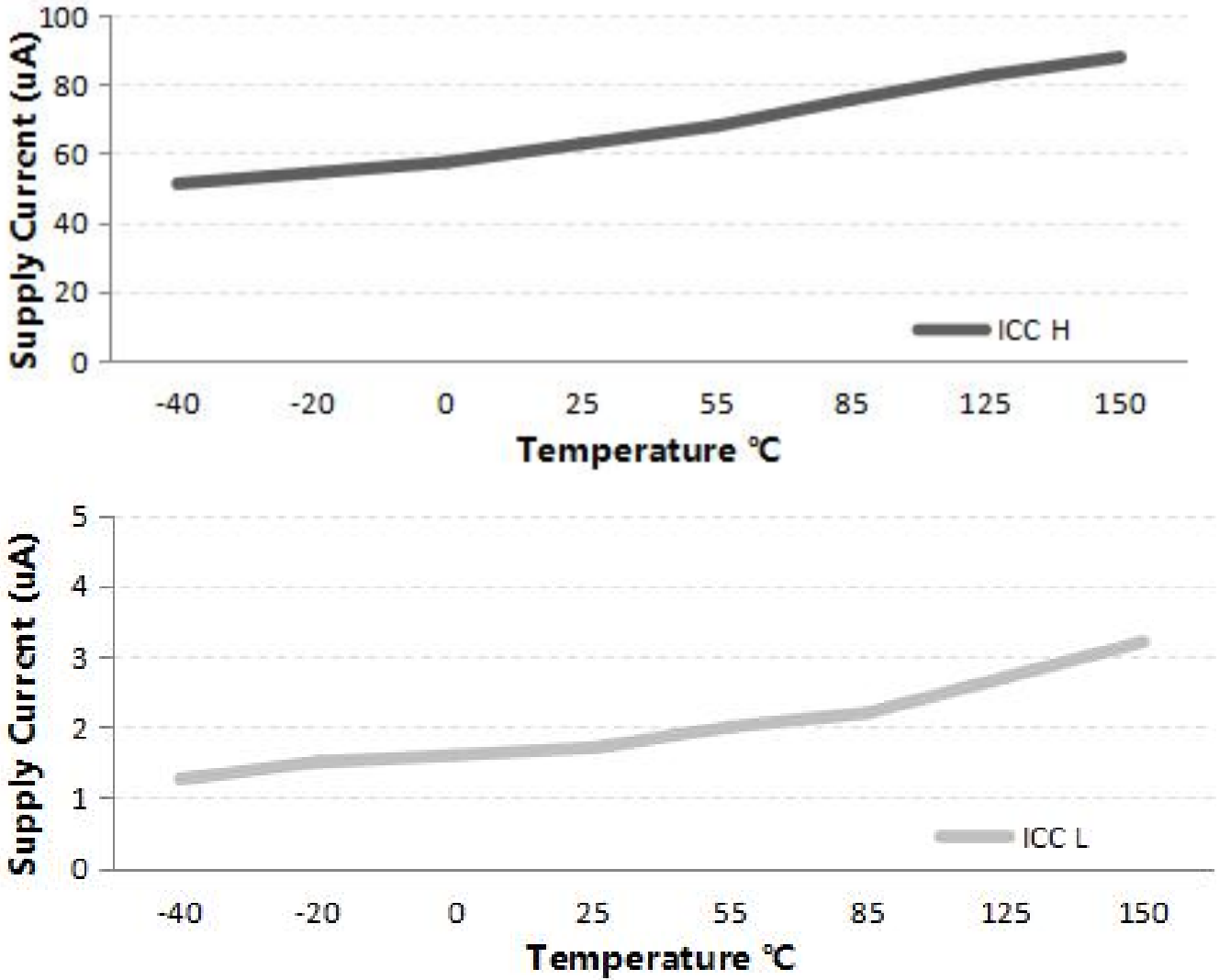

Figure.6 Supply Current vs. Temperature

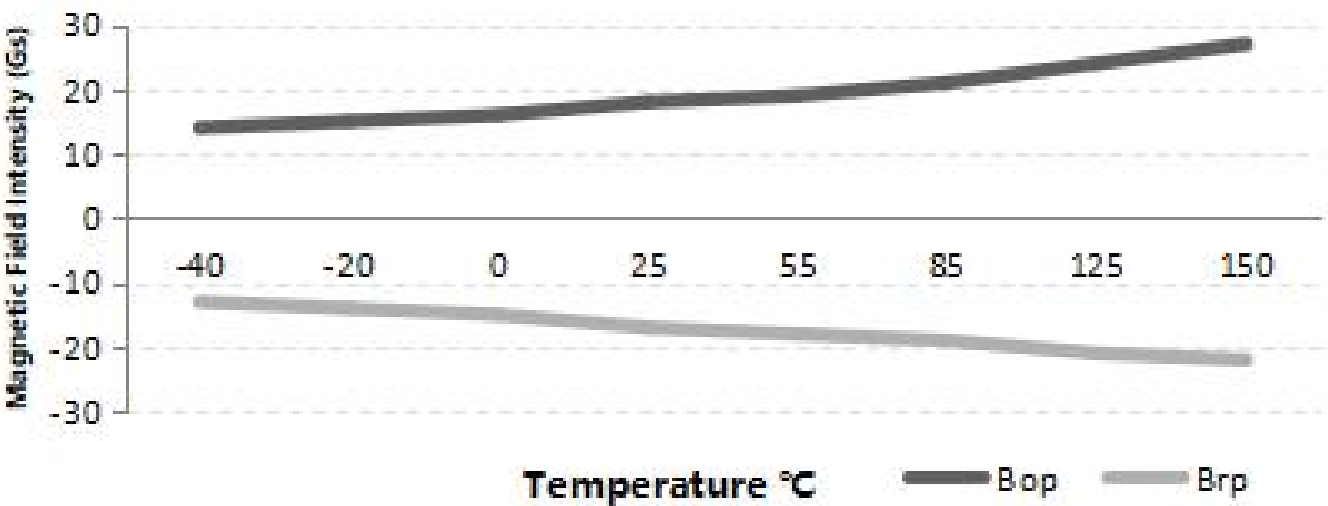

Figure.7 Magnetic Characteristics vs. Temperature (BOP & BRP)

10.5 Characteristic Performance

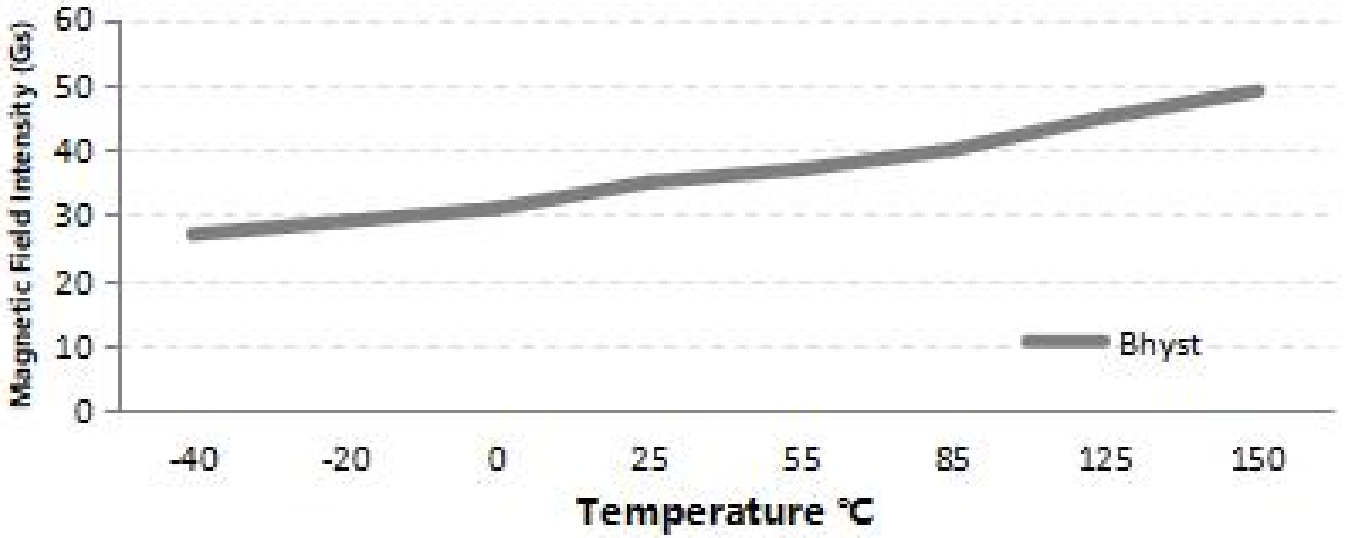

Figure.8 Magnetic Characteristics vs. Temperature (Bhyst)

10.6 Typical Output Waveform

MT882XDT-1616 as example

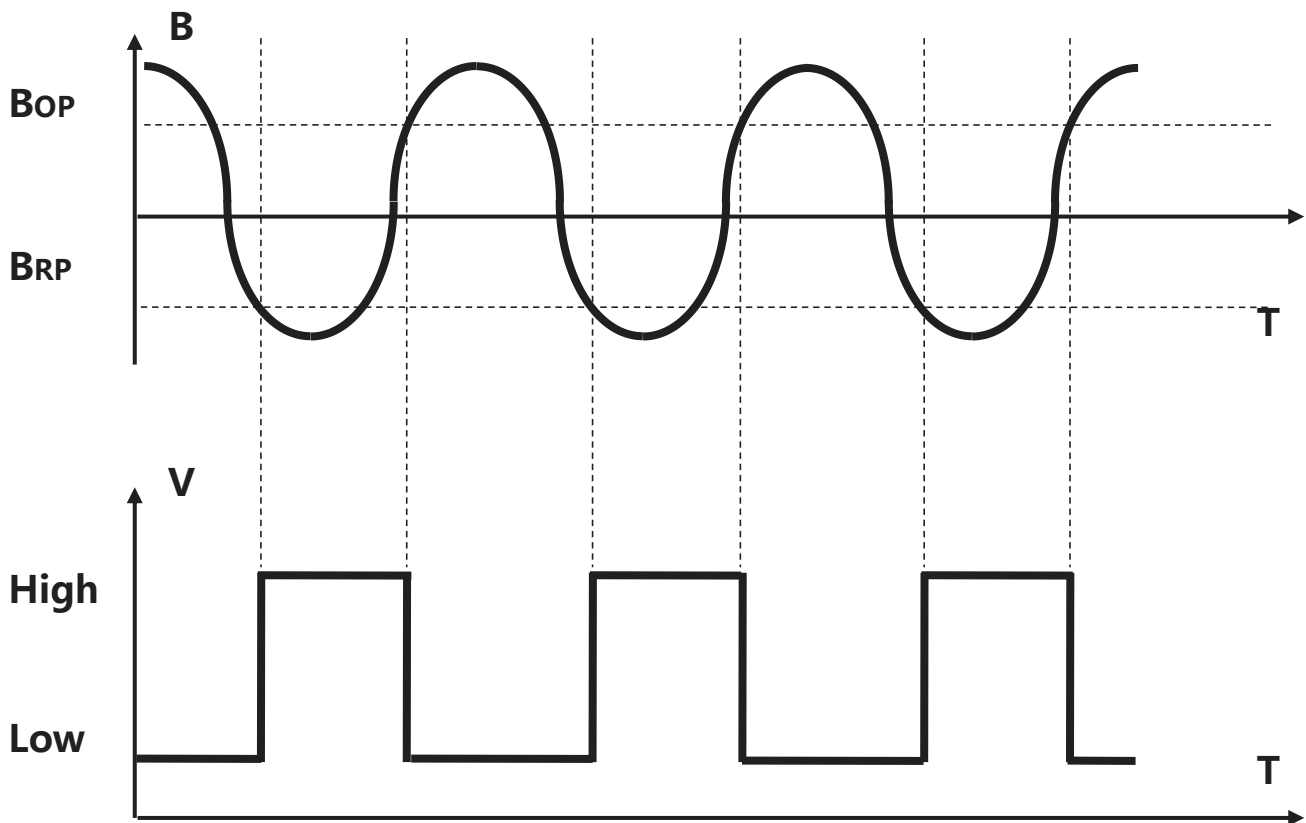

Figure.9 Digital Output vs. Magnetic Flux Density

11 Typical Application Circuit

MT882XAT as example

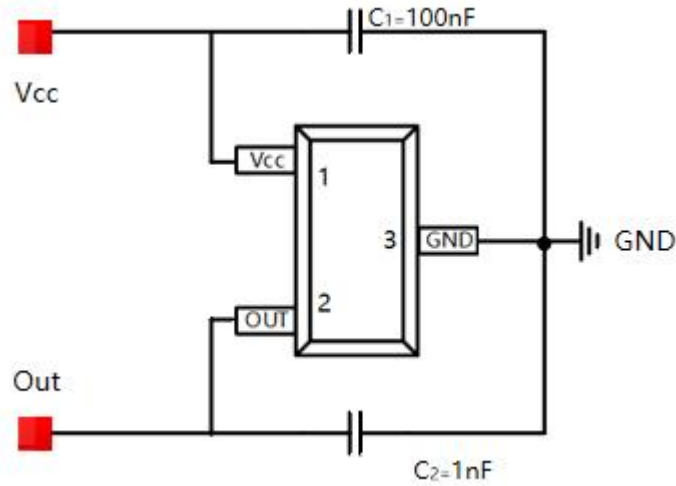

Figure.10 Typical Application Circuit

MT882XDT-1616 as example

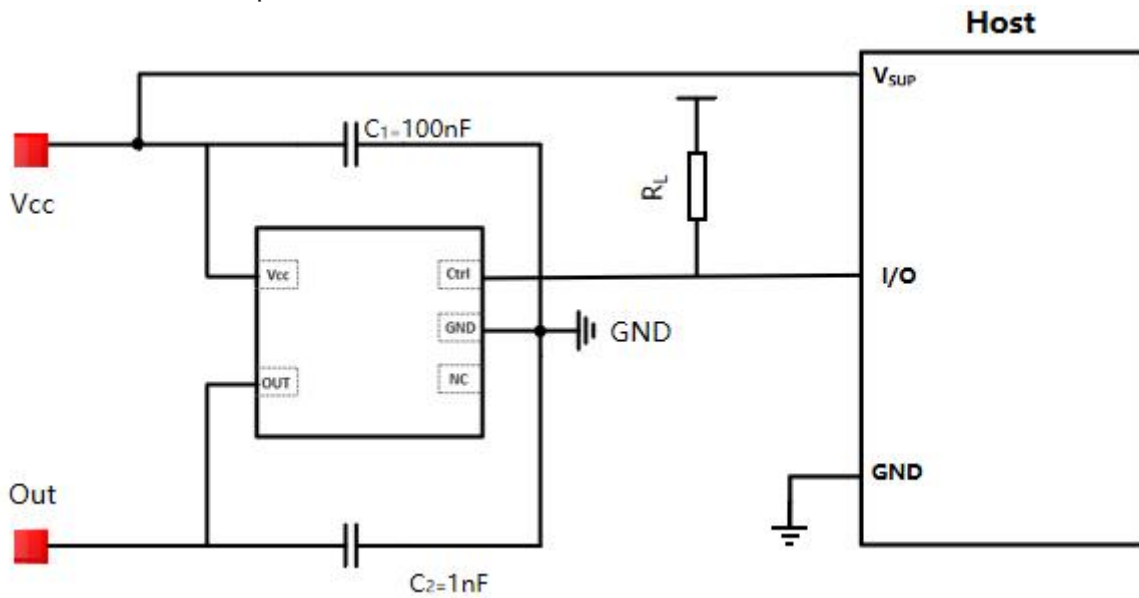

Figure.11 Typical Application Circuit

12 Package Material Information (For Reference Only – Not for Tooling Use)

12.1 SOT-23 Package Information

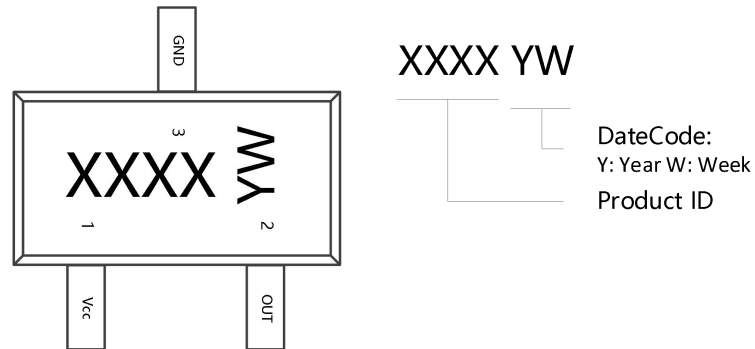

Figure.12 SOT-23 Chip Marking Spec

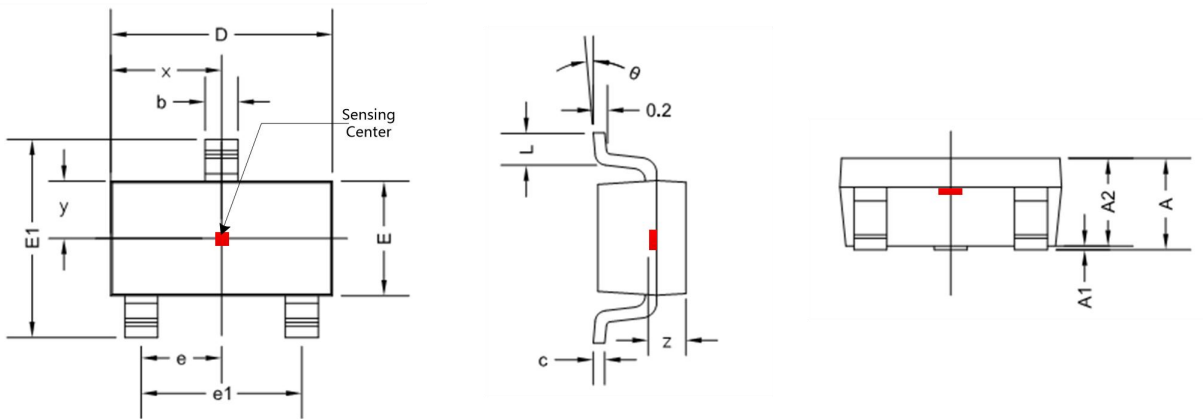

Figure.13 SOT-23 Package Drawing

Symbol	Dimensions in Millimeters		Dimensions in Inches	
	Min	Max	Min	Max
A	1.050	1.300	0.041	0.051
A1	0.000	0.150	0.000	0.006
A2	1.000	1.200	0.039	0.047
b	0.300	0.500	0.012	0.020
c	0.080	0.220	0.003	0.009
D	2.800	3.020	0.110	0.119
E	1.500	1.700	0.059	0.067
E1	2.600	3.000	0.102	0.118
e	0.950 TYP		0.037 TYP	
e1	1.800	2.000	0.071	0.079
L	0.300	0.600	0.012	0.024
θ	0 °	8 °	0 °	8 °
x	1.460 TYP		0.057 TYP	
y	0.800 TYP		0.032 TYP	
z	0.600 TYP		0.024 TYP	

12.2 DFN1616 Package Information

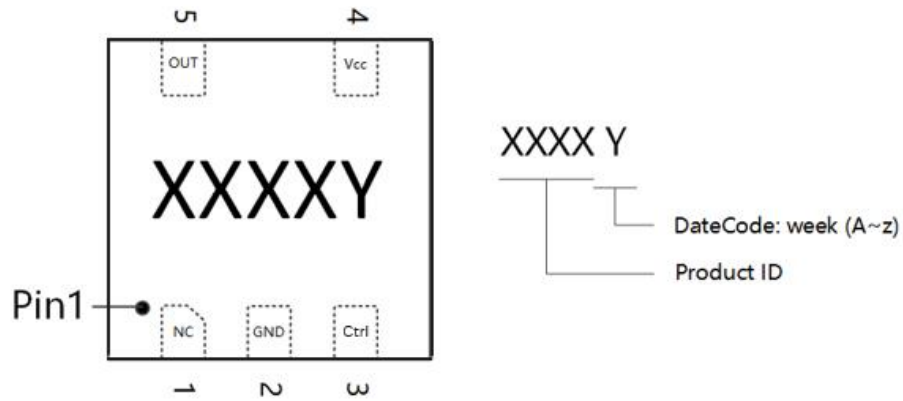

Figure.14 DFN1616 Chip Marking Spec

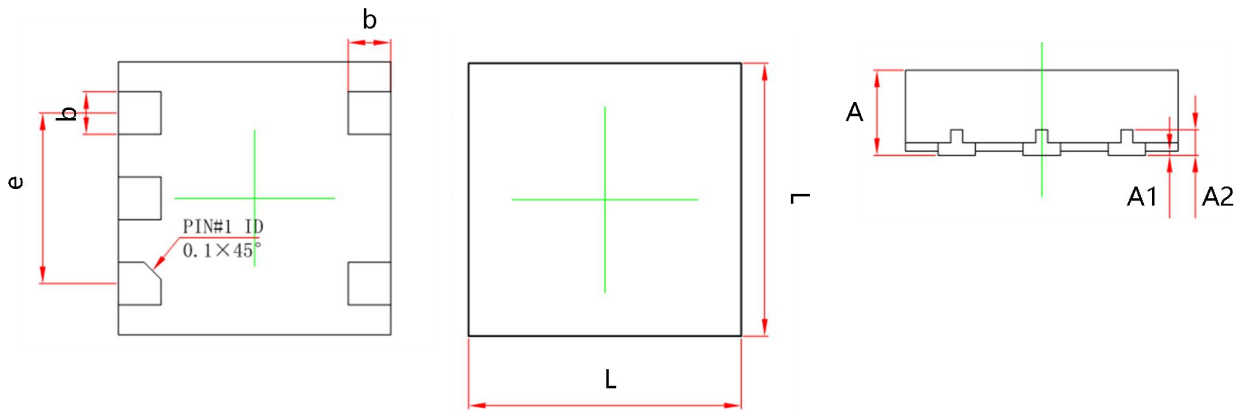

Figure.15 DFN1616 Package Drawing

Symbol	Dimensions in Millimeters		Dimensions in Inches	
	Min	Max	Min	Max
A	0.450	0.550	0.018	0.022
A1	0.000	0.050	0.000	0.002
A2	0.150 TYP		0.006 TYP	
L	1.550	1.650	0.061	0.065
b	0.200	0.300	0.008	0.012
e	1.000 TYP		0.039 TYP	

13 Copy Rights and Disclaimer

1. This document may not be reproduced or duplicated, in any form, in whole or in part without prior written consent of MagnTek . Copyrights © 2022, MagnTek Incorporated.
2. MagnTek reserves the right to make changes to the information published in this document at anytime without notice.
3. MagnTek' s products are limited for use in normal commercial applications. MagnTek' s products are not to be used in any device or system, including but not limited to medical life support equipment and system.

For the latest version of this document, please visit our website: www.magntek.com.cn